



2023 Design Guidelines

Real Estate Development + Facilities

DESIGN GUIDELINES

ACKNOWLEDGEMENTS

We would like to thank the following individuals and departments for their role in creating and maintaining these Design Guidelines.

Executive Leadership

Vicki Match Suna, AIA | Executive Vice President and Vice Dean for RED+F
David Resnick, AIA | Vice President for Project Planning, Design and Construction

Editor-in-Chief

Fred Alvarez, AIA | Senior Director of Design

Editors

Leeza Springer, PMP | Senior Design Manager
Paul Mulyk, PE, BCxP | Director Engineering and Commissioning

Contributing Divisions of Real Estate Development and Facilities (RED+F)

Design Studio
Project Planning, Design and Construction
Facilities Management and Operations
Space Planning and Management
Energy and Sustainability
Environmental Health and Safety (EH&S)
Environmental Services / Building Services
Campus Security
Project Support Office

Contributing Departments

Medical Center Information Technology (MCIT)
Infection Prevention and Control (IPC)
Occupational and Industrial Orthopedic Center (OIOC)

TABLE OF CONTENTS

LETTER FROM THE EXECUTIVE VICE PRESIDENT AND VICE DEAN 1

INTRODUCTION 3

UPDATES AND REVISIONS **(UPDATED)** 4

Section 1: Architectural Guidelines

General Information

MASTER PLAN GUIDING PRINCIPLES..... 7

DESIGN PRINCIPLES..... 8

GENERAL PROJECT REQUIREMENTS **(UPDATED)** 9

A/E DESIGN FEE GUIDELINES 12

PROJECT DELIVERY PROCESS **(UPDATED)** 20

BASIS OF DESIGN 30

DESIGN REVIEW PROCESS **(UPDATED)** 31

PRESENTATION MATERIALS 35

FINISH & FURNITURE BOOKLETS 41

Architecture / Interiors

CAD DOCUMENTATION STANDARDS **(UPDATED)** 47

BUILDING INFORMATION MODELING..... 51

SPACE PLANNING **(UPDATED)** 54

ERGONOMICS 91

ROOM FINISHES **(UPDATED)** 95

MATERIAL LEGEND **(UPDATED)** 137

PAINT COLORS **(UPDATED)** 162

ART PROGRAM 166

ROOM NUMBERING, SIGNAGE & WAYFINDING **(UPDATED)** 168

FURNITURE **(UPDATED)** 170

PANTRY APPLIANCES **(UPDATED)** 231

PLUMBING FIXTURES **(UPDATED)** 235

EMERGENCY PLUMBING FIXTURES 254

TOILET ACCESSORIES **(UPDATED)** 256

BUILDING ACCESSORIES **(UPDATED)** 273

RECYCLING PROGRAM **(UPDATED)** 281

DOOR HARDWARE **(UPDATED)** 302

ENVIRONMENTAL HEALTH & SAFETY **(UPDATED)** 325

ENVIRONMENTAL SUSTAINABILITY **(UPDATED)** 327

INFORMATION TECHNOLOGY 333

SECURITY..... 337

MISCELLANEOUS **(UPDATED)** 340

DOS AND DON'TS **(UPDATED)** 346

Section 2: Engineering Guidelines

TABLE OF CONTENTS 353

GENERAL **(UPDATED)** 358

MECHANICAL **(UPDATED)** 363

ELECTRICAL **(UPDATED)** 405

PLUMBING **(UPDATED)** 425

FIRE PROTECTION **(UPDATED)** 435

FIRE ALARM **(UPDATED)** 442

BUILDING MANAGEMENT SYSTEM **(UPDATED)** 444

Section 3: Project Close-Out

CLOSE-OUT PACKAGE..... 545

PHOTOGRAPHY **(UPDATED)** 547

POST-OCCUPANCY EVALUATIONS 549

LETTER FROM THE EXECUTIVE VICE PRESIDENT AND VICE DEAN

This is an especially exciting time for NYU Langone Health, as our trifold mission to serve, teach, and discover is achieved daily through an integrated academic culture devoted to excellence in patient care, education, and research.

The transformation of our campus is key to achieving this vision. Building upon a legacy of excellence, we are creating a uniquely seamless environment in which patient care, research, and education blend synergistically across all areas of our institution. Our researchers will have state-of-the-art laboratories built to encourage collaboration, which in turn will speed the translation of scientific discoveries to the patient bedside; and, our students and faculty will work together in modern educational facilities equipped with the latest technological tools. This integration culminates in our paramount focus—to set new standards of excellence in providing for the health and comfort of patients and their families.

In line with these goals is adherence to a set of comprehensive design standards, shaped by a set of guiding principles for the built environment:

- *Design Quality*
- *Construction Quality*
- *Cost Effectiveness*
- *Schedule Compliance*
- *Design Flexibility*
- *Efficiency, Functionality and Practicality*
- *Intuitive Wayfinding*
- *Durable Materials*
- *Attention to Detail*
- *Collaborative Process*

The mission of the Real Estate Development and Facilities (RED+F) department at NYU Langone is to plan, develop, operate and maintain our growing network of facilities and, in doing so, to provide the foundation for our growth and success in the 21st century. The design guidelines put forth here will enable RED+F to work efficiently and successfully with its partners in the design community to play a vital role in translating our vision into the physical reality.



Vicki Match Suna, AIA
Executive Vice President and Vice Dean
Real Estate Development and Facilities

INTRODUCTION

Purpose

With over 13 million square feet at locations throughout the New York metropolitan region, NYU Langone Health leases, owns and operates an enormous variety of buildings. The *NYU Langone Health – Design Guidelines* have been created as a guide for architects, interior designers, engineers and Real Estate Development + Facilities Project Managers (PM), etc. to design existing and new facilities. We understand all projects are unique. As such, it is expected the Architectural/Engineering Team (A/E Team) shall take into account existing site conditions, user requirements, building codes, these Design Guidelines, and all other requirements as necessary to design our facilities. In addition, these guidelines are not intended to repeat or replace any code mandated requirements. Compliance with relevant codes is the sole responsibility of the A/E Team.

Goals

- *Efficiency*

A principal goal of the Design Guidelines is to improve the efficiency of the design process. We can improve operations and maintenance by creating a commonality of systems and products across our expanding portfolio. Where appropriate, approved materials and products are indicated in the guidelines. The aim is not to limit design expression but to guide the architects and engineers toward solutions that are in conformance with our construction and maintenance practices. Improving efficiency in design, construction and operations is of substantial financial benefit to our institution.

- *Design Excellence and Quality Construction*

NYU Langone Health is committed to design excellence, and stands by the premise that intelligent planning, inspired design, meticulous documentation, and quality construction are all indispensable to this effort, and will bring added value to our organization. The guidelines have been created in support of this goal.

Applicability

These guidelines will be updated periodically. The PM on a particular project will advise when new updates are available.

Access and Exceptions

The Design Guidelines can be accessed on both BuildFlow (the NYU Langone Health construction document management site) and the RED+F website:

<http://nyulangone.org/vendor-supplier-information/design-guidelines>

Designers may seek approval of deviations from or alternatives/additions to the Design Guidelines by written request to the PM, who will forward such requests to the RED+F Design Studio for review. The PM will advise the designer in writing whether or not the proposed deviation, alternative or addition is approved. Under no circumstances shall deviation from the Design Guidelines be construed as a basis for additional services.

UPDATES AND REVISIONS

These guidelines will be updated periodically. Below is a Legend and Summary of how and what changes have been incorporated into the 2023 release of the NYU Langone Health Design Guidelines:

Legend

- ***(CAPITALIZED BOLD ITALIC)*** text following subsection titles listed in the Table of Contents shall be used to identify New and Updated subsections.

Summary

The following subsections in the 2023 NYU Langone Health Design Guidelines have been ***UPDATED:***

Section 1: Architectural Guidelines

- Updates and Revisions
- General Project Requirements
- Project Delivery Process
- Design Review Process
- CAD Documentation Standards
- Space Planning
- Room Finishes
- Material Legend
- Paint Colors
- Room Numbering, Signage & Wayfinding
- Furniture
- Pantry Appliances
- Plumbing Fixtures
- Toilet Accessories
- Building Accessories
- Recycling Program
- Door Hardware
- Environmental Health & Safety
- Environmental Sustainability
- Miscellaneous
- Dos and Don'ts

Section 2: Engineering Guidelines

- General
- Mechanical
- Electrical
- Plumbing
- Fire Protection
- Fire Alarm
- Building Management System

Section 3: Project Close-Out

- Photography

1. ARCHITECTURE

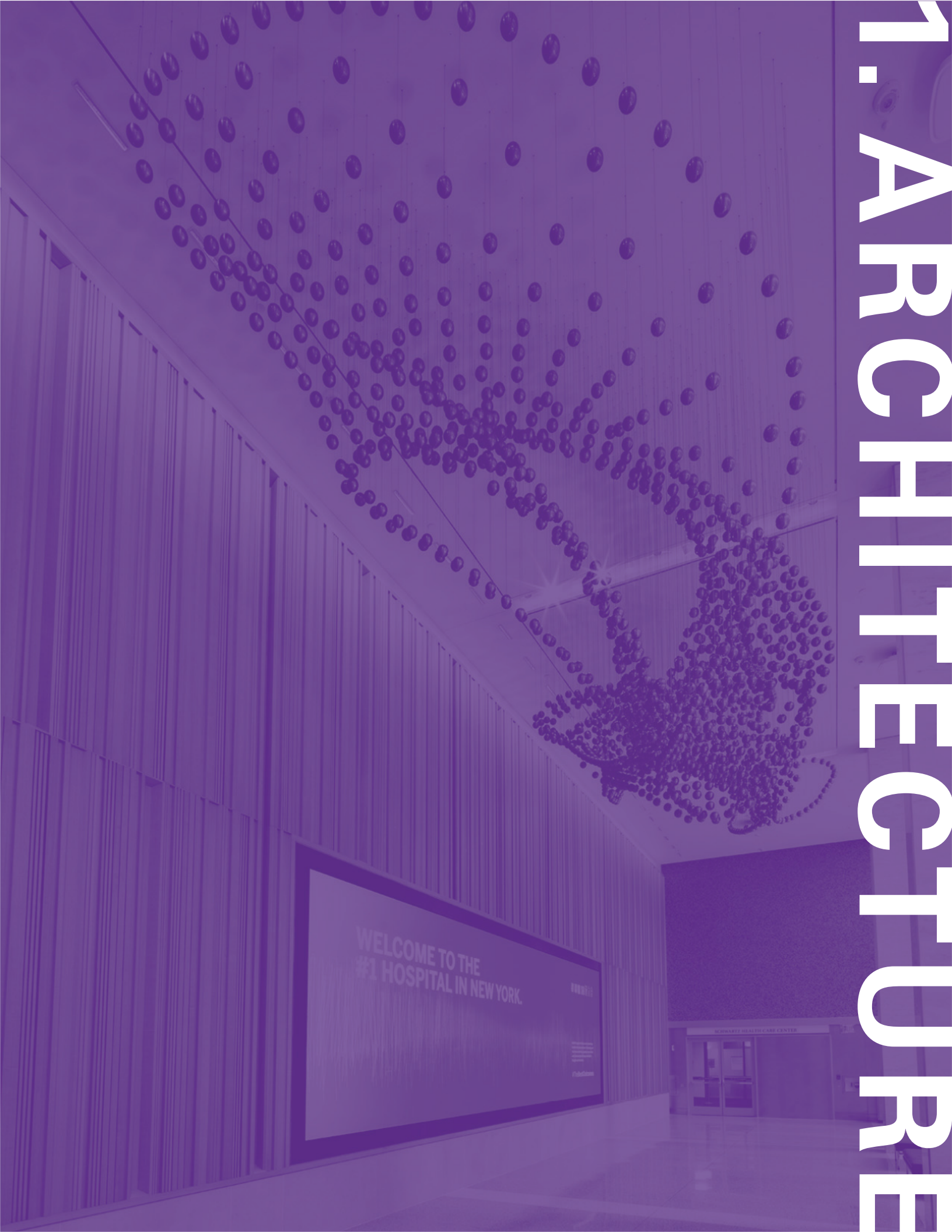

MASTER PLAN GUIDING PRINCIPLES

NYU Langone Health has developed master plan guiding principles to help direct our collective efforts in the transformation of our campus. All projects undertaken at NYU Langone shall be planned in accordance with these master plan guiding principles.

1. All future facility improvement and development should redefine and reposition NYU Langone Health in the New York metropolitan region.
2. NYU Langone Health will be a leader in patient-centered care.
3. The physical environment should support efficient, LEAN-based operations in all enterprises of the campus.
4. All programs and facilities should foster clinical and translational research that:
 - is integrated into programs and facilities
 - promotes collaboration in care delivery and research
 - can support NYU Langone to broaden sources of funding for research
5. The physical environment should encourage flexibility and an adaptive environment.
6. NYU Langone Health will be a premier “service” organization that is:
 - safe
 - supportive of faculty, clinicians, students, patients and visitors
 - disease-focused
 - innovative
 - responsive to market forces and dynamics
7. The faculty response to clinical needs must be fiscally responsible and provide clear direction for expansion over time, as funds become available.
8. Consistent with the NYU Langone mission and as they support strategic areas, innovative methods and technologies will be anticipated and incorporated into clinical programs and practices.
9. All facilities should provide space in support of the educational and training mission of the Medical School and the University.
10. The care that we provide at NYU Langone Health results from a team effort working on behalf of the patient and family.
11. All facilities should embrace sustainable and evidence-based parameters in design, materials, equipment and technology.

DESIGN PRINCIPLES

NYU Langone Health is committed to design excellence and demands the highest quality built environment. We stand by the premise that intelligent planning, inspired design, meticulous documentation and quality construction are all indispensable to this effort. As part of our mission devoted to excellence in patient care, education, and research, we have developed the following design principles:

1. *Design Quality*

- Design solutions must be timeless with a clearly organized concept, developed and reinforced with appropriate materials and details.
- Provide innovative solutions that create safe, secure and supportive environments and improve workflow.
- Develop design solutions that strengthen the NYU Langone brand.

2. *Construction Quality*

- The built environment must have the highest possible quality of construction appropriate to the project scope, budget and schedule.

3. *Cost Effectiveness*

- Design solutions must be cost effective and fiscally responsible.

4. *Schedule Compliance*

- Design and construction schedules must be maintained.

5. *Design Flexibility*

- The physical environment should encourage flexibility and adaptability and provide clear direction for expansion over time.

6. *Efficient, Functional and Practical*

- Designs should look to improve workflow, support efficient, LEAN-based operations, and create environments that are easily maintained.

7. *Intuitive Wayfinding*

- The circulation pattern from point of entry to final destination must be clearly visible and easily understood.

8. *Durable Materials*

- Materials and finishes must last over time and be easily maintainable.

9. *Attention to Detail*

- It is critical that details are thoughtfully designed, thoroughly documented and carefully constructed.

10. *Collaborative Process*

- NYU Langone Health promotes an integrated team approach in the development and construction of projects. It is essential that all stakeholders have input in the process.

GENERAL PROJECT REQUIREMENTS

1. *Architects Agreement*

Architects are required to execute NYU Langone Health’s Standard Master Owner - Architect Agreement (the “Agreement”); no exception may be taken to the terms and conditions of the Agreement. In the event of any inconsistency between these Design Guidelines and the provisions of the Agreement, the provisions of the Agreement shall govern.

2. *Communication and Approach*

NYU Langone Health promotes a team approach in the development and construction of projects. We believe it is essential that all stakeholders have input into the process. This includes the User, Real Estate Development + Facilities (RED+F), Medical Center Information Technology (MCIT), Environmental Health & Safety (EH&S), Security, Environmental Services/ Building Services, etc. The RED+F Project Manager (PM) will act as the main contact on the project to ensure all elements are coordinated.

The Architectural/Engineering team (A/E Team) is encouraged to initiate and sustain open communications throughout the project. All communication with the A/E Team will be handled through their primary contact, the PM. Other contacts listed in this document should only be contacted at the direction of the PM.

3. *Roles and Responsibilities*

The following is a list of NYU Langone departments with whom the A/E Team will likely have regular contact during the planning, design and construction process:

- ***Real Estate Development and Facilities (RED+F)*** - RED+F is the client. They provide planning information as well as architecture and engineering design review for projects. This includes information on related or concurrent projects, NYU Langone practices, policies and space standards. RED+F has a staff of in-house architects, engineers and designers that oversee the design of all NYU Langone capital projects.
- ***Sponsor*** - The Sponsor for a capital project is the department or group that is funding the project.
- ***User*** - The User is the department or group that will occupy the project after it is constructed. They have an important responsibility to provide feedback on their functional and programmatic needs, workflow requirements and to sign off on the plan. The plan sign-off is a critical schedule milestone that determines when Construction Documents begin and when the Users will be able to move in. The Users will be shown the proposed materials and finishes for the project and be allowed to provide input on functional issues. The aesthetic approval of the finishes will be the sole responsibility of RED+F.

The following is a list of key project participants with whom the A/E Team will likely have regular contact during the planning, design and construction process:

- **RED+F Project Manager (PM)** - The PM is the primary contact for all aspects of the project. They act as the central point of contact for collecting and disseminating information, project schedule, project budget and all communication. PMs utilize resources within the NYU Langone Health community as needed to support the project objectives.
- **Representatives from the following RED+F Divisions -**
 - **Design Studio** - The Design Studio will provide architectural and interior design review on capital construction projects (including Art and Signage). In order to provide a consistent vision for the built environment, the Design Studio will provide approval of the final layouts, furniture, finishes, fixtures and accessories.
 - **Space Planning and Management** - The Space Planning and Management group will provide backgrounds of existing conditions, assign room numbers, assist with BuildFlow and maintain “as-built” information.
 - **Facilities Management and Operations** - Facilities Management and Operations will provide engineering design review on construction projects.
 - **Commissioning** - RED+F Commissioning (a subset of Facilities Management) will provide engineering design review as well as engineering and commissioning oversight on construction projects.
 - **Real Estate and Housing** - The Real Estate and Housing division administers the leasing and acquisition of real estate property, provides portfolio management services, and manages the operations of commercial and residential property for NYU Langone Health.
 - **Energy and Sustainability** - The Energy and Sustainability Manager will assist the PM with setting and meeting NYU Langone’s sustainability goals on capital construction projects.
 - **Environmental Services or Building Services** - Environmental Services or Building Services maintain NYU Langone’s buildings and grounds providing cleaning and waste management services. They will review the proposed maintenance support spaces and FFE items from a cleaning operations perspective.
 - **Environmental Health and Safety (EH&S)** - The EH&S PM will assist the PM with various aspects of health and safety including asbestos abatement, hazardous waste removal and OSHA safety requirements.
 - **Clinical Engineering** - Clinical Engineering coordinates the ordering and installation of medical equipment.
 - **Campus Security** - Campus Security will review and approve the proposed security solutions on capital construction projects.
 - **Food & Nutrition and Dietary Services** – Food & Nutrition and Dietary Services will review proposed food and nutrition spaces from an operations perspective.

- *Medical Center Information Technology (MCIT)* - The MCIT PM will assist the PM with coordinating the IT, telecommunication, audio-visual and associated cabling requirements for capital construction projects.
- *Infection Prevention and Control (IPC)* - Infection Prevention and Control will review capital projects for compliance with NYULH policies and procedures surrounding environmental cleaning, disinfecting, sterilization, and infection control.

4. *Adherence to Budget and Schedule*

Cost and schedule control are of paramount concern to NYU Langone Health. As per the Standard Master Owner - Architect Agreement, the Architect is responsible to meet the project's budget and schedule goals. Evaluations of the Architect's work and consideration for future projects will be made based on meeting these budget and schedule goals, adherence to the Design Principles, and overall RED+F and User satisfaction.

A/E DESIGN FEE GUIDELINES

NYU Langone Health is committed to providing design excellence based on a fair and reasonable A/E fee. The purpose of these guidelines is to outline the process for utilizing the NYU Langone Health A/E Fee Percentage schedule for capital projects. The information provided includes:

1. General Information
2. A/E Fees
3. Program Types
4. A/E Fee Reference Tables
5. A/E Fee Calculator
6. Sample Calculations

This is a guideline and Project Managers are expected to use critical thinking skills along with the tools provided here to ensure a responsible fee is paid and that NYU Langone Health does not under or overpay for any services.

1. General Information

- **Basic Services** - The following disciplines are included as part of Basic Services per the Standard Master Owner – Architect Agreement:
 - Architecture
 - Mechanical, Electrical, Plumbing and Fire Protection Engineering
 - Structural Engineering
 - Furniture, Fixtures & Equipment (FFE)
 - Signage

- **Full Scope of Services** - The full scope of services for a particular project shall be as described in the Standard Master Owner – Architect Agreement and amended per Services Order. For example, although coordination work associated with Security, IT/AV is not included as part of Basic Services it may be added via Services Order. In such cases, the construction budget shall include the costs for these items and the A/E fee shall include these services.

- **Compensation per Phase** - Compensation shall be by phase as follows per the Standard Master Owner – Architect Agreement or as amended per Services Order:

- Site Investigation, Analysis and Feasibility Phase:	5%
- Schematic Design Phase:	10%
- Design Development Phase:	20%
- Construction Documents Phase:	35%
- Bidding and Negotiation Phase:	5%
- Construction Phase:	15%
- Substantial Completion:	5%
- Close-Out Phase:	5%
Total	100%

2. *A/E Fees* - A/E Fees shall be calculated by the Project Manager using the:

- Program Type (based on Table 1 below),
- Construction Budget, and
- Complexity Multiplier (1.0 or based on Table 4 below).

3. *Program Types* - The A/E fee varies based on the following programmatic categories:

TABLE 1 – PROGRAM TYPES
<p><i>Program Type I</i></p> <ul style="list-style-type: none"> - Plant Maintenance Workshops - Standard Parking Structures - Utility Structures / Service Buildings - Warehouse / Storage Facilities
<p><i>Program Type II</i></p> <ul style="list-style-type: none"> - Administrative Offices - Academic and Medical Classrooms - Physical Plant upgrades
<p><i>Program Type III</i></p> <ul style="list-style-type: none"> - Dormitories and Student Housing - Dry / Computational Research programs - Physician Practice renovation projects (non-Article 28)
<p><i>Program Type IV</i></p> <ul style="list-style-type: none"> - Cafeterias and Food Service - Engineering Labs and Wet Research Labs – Up to BSL2 - Medical Labs - Outpatient Surgical Centers and Specialty Clinics - Physician Practice renovation projects (Article 28) - Telecom / Data Processing Facilities - Theaters, Performance Halls and Auditorium Assembly
<p><i>Program Type V</i></p> <ul style="list-style-type: none"> - Animal Research Facilities - Hospital - Specialty Research Labs / Support Facilities – BSL3 & Above

4. A/E Fee Reference Tables

TABLE 2 – A/E FEE PERCENTAGE					
CONSTRUCTION BUDGET	Program Type I	Program Type II	Program Type III	Program Type IV	Program Type V
\$50,000,000 and Above	To be negotiated.				
\$50,000,000	4.15%	4.55%	4.95%	5.35%	5.75%
\$25,000,000	4.35%	4.85%	5.35%	5.85%	6.35%
\$10,000,000	4.75%	5.35%	5.95%	6.55%	7.15%
\$5,000,000	5.60%	6.30%	7.00%	7.70%	8.40%
\$1,000,000	6.90%	7.75%	8.60%	9.45%	10.30%
\$500,000	8.40%	9.40%	10.40%	11.40%	12.40%
\$250,000	9.40%	10.90%	12.40%	13.90%	15.40%
\$100,000 - \$250,000	Not to exceed \$30,000				
<\$100,000	Not to exceed \$20,000				
Notes:					
1. The above percentages are for both renovations and new construction projects.					
2. When the construction budget falls between tabular limits, the Fee Percentage is determined by linear interpolation.					

TABLE 3 – COMPLEXITY MULTIPLIER EXAMPLES	
Multiplier Range	Examples
0.50 – 0.99	Project Scope <u>less than</u> Basic Services such as: Replacement of a Single System; Limited Documentation; Interiors Project to Match Existing Conditions; Project not Requiring One or More Basic Service Task(s)
1.00	Project Scope <u>equal to</u> standard Basic Services per Master Agreement
1.01 – 1.50	Project Scope <u>in excess of</u> Basic Services such as: Project Requiring Additional Services in Excess of Standard Basic Services; Project with More than One Construction Phase and/or Bid Package
Notes:	
1. The Project Manager shall use Table 4 - Complexity Multiplier Worksheet on projects that differ from standard Basic Services to determine the Complexity Multiplier.	

5. A/E Fee Calculator

PROJECT INFORMATION			
PIM #:	Text Here	RED+F PM:	Text Here
PROJECT NAME:	Text Here	RED+F PD:	Text Here
This is a guideline and Project Managers are expected to use critical thinking skills along with the tools provided here to ensure a responsible fee is paid and that NYU Langone Health does not under or overpay for any services.			

A/E FEE CALCULATOR					
Program Type <i>(based on Table 1)</i>	Program Type I	Program Type II	Program Type III	Program Type IV	Program Type V
Program Description	Text Here	Text Here	Text Here	Text Here	Text Here
Construction Budget	\$0	\$0	\$0	\$0	\$0
Fee Percentage <i>(automatically based on Table 2)</i>	0.00%	0.00%	0.00%	0.00%	0.00%
Complexity Multiplier <i>(1.0 or based on Table 4)</i>	1.00	1.00	1.00	1.00	1.00
SUB-TOTAL A/E Fee	\$0	\$0	\$0	\$0	\$0
Misc. A/E Fee Costs <i>(items not represented in the Complexity Multiplier)</i>	\$0				
TOTAL Maximum Allowable A/E Fee <i>(not including Reimbursables)</i>	\$0				
Proposed Fee from A/E Team <i>(not including Reimbursables)</i>	\$0				
Delta	\$0				

- Instructions:**
- The A/E Fee Calculator shall be used for typical NYULH capital projects with construction budgets >\$250k.
 - RED+F Project Manager (PM) to input items shown in red.
 - For projects consisting of more than one program type multiple columns may be used.
 - The Construction Budget includes hard costs on straight-time (plus insurance) but does not include soft costs (i.e. design fees, contingencies, furniture, etc.).
 - When the Construction Budget falls between tabular limits the Fee Percentage will be automatically calculated by linear interpolation from Table 2.
 - The PM shall use page 2 to determine the Complexity Multiplier and to list any additional comments.
 - Misc. A/E Fee Items are any additions or deletions to Basic Services not represented by the Complexity Multiplier.
 - The PM shall provide a breakdown of the Misc. A/E Fee Costs in the Comments section on page 2.
 - The PM shall submit both sheets of this document.

TABLE 1 - PROGRAM TYPES			
Program Type I	- Plant Maintenance Workshops - Standard Parking Structures	- Utility Structures/Service Buildings - Warehouse/Storage Facilities	Program Type IV
Program Type II	- Administrative Offices - Academic and Medical Classrooms	- Physical Plant upgrades	- Cafeterias and Food Service - Engineering Labs and Wet Research Labs - Up to BSL2 - Physician Practice renovation projects (Article 28) - Telecom/Data Processing Facilities
Program Type III	- Dormitories and Student Housing - Dry/Computational Research programs - Physician Practice renovation projects (non-Article 28)		- Medical Labs - Outpatient Surgical Centers and Specialty Clinics - Theaters, Performance Halls and Auditorium Assembly Program Type V - Animal Research Facilities - Hospital - Specialty Research Labs /Support Facilities - BSL3 & Above

TABLE 2 - A/E FEE PERCENTAGE										
CONSTRUCTION BUDGET	Program I	Type	Program II	Type	Program III	Type	Program IV	Type	Program V	Type
\$50,000,000 and above	To be negotiated.									
\$50,000,000	4.15%		4.55%		4.95%		5.35%		5.75%	
\$25,000,000	4.35%		4.85%		5.35%		5.85%		6.35%	
\$10,000,000	4.75%		5.35%		5.95%		6.55%		7.15%	
\$5,000,000	5.60%		6.30%		7.00%		7.70%		8.40%	
\$1,000,000	6.90%		7.75%		8.60%		9.45%		10.30%	
\$500,000	8.40%		9.40%		10.40%		11.40%		12.40%	
\$250,000	9.40%		10.90%		12.40%		13.90%		15.40%	
\$100,000 - \$250,000	Not to exceed \$30,000									
<\$100,000	Not to exceed \$20,000									

- Notes:**
- The above percentages are for both renovations and new construction projects.
 - When the construction budget falls between tabular limits, the Fee Percentage is automatically calculated by linear interpolation.

SIGNATURES	
RED+F PM / Date _____	RED+F PD / Date _____
RED+F Sr.DoD / Date _____	RED+F VP of DC / Date _____

PROJECT INFORMATION			
PIM #:	Text Here	RED+F PM:	Text Here
PROJECT NAME:	Text Here	RED+F PD:	Text Here
This is a guideline and Project Managers are expected to use critical thinking skills along with the tools provided here to ensure a responsible fee is paid and that NYU Langone Health does not under or overpay for any services.			

TABLE 3 - COMPLEXITY MULTIPLIER EXAMPLES	
Multiplier Range	Examples
0.50 - 0.99	Project Scope <u>less than</u> Basic Services such as: Replacement of a Single System; Limited Documentation; Interiors Project to Match Existing Conditions; Project not Requiring One or More Basic Service Task(s)
1.00	Project Scope <u>equal to</u> standard Basic Services per Master Agreement
1.01 - 1.50	Project Scope in <u>excess of</u> Basic Services such as: Project Requiring Additional Services in Excess of Standard Basic Services; Project with More than One Construction Phase and/or Bid Package
Notes: 1. The Project Manager shall use Table 4 - Complexity Multiplier Worksheet on projects that differ from standard Basic Services to determine the Complexity Multiplier.	

TABLE 4 - COMPLEXITY MULTIPLIER WORKSHEET							
BASIC SERVICES	Complexity Multiplier Range	Program Type I	Program Type II	Program Type III	Program Type IV	Program Type V	Remarks
Architecture	0.00 - 0.50						
MEP / FP Engineering	0.00 - 0.30						
Structural Engineering	0.00 - 0.10						
Furniture, Fixtures & Equipment (FFE)	0.00 - 0.06						
Signage	0.00 - 0.04						
SUB-TOTAL of Basic Services	0.00 - 1.00	0.00	0.00	0.00	0.00	0.00	
ADDITIONAL SERVICES							
Landscape Design	0.00 - 0.05						
Geotechnical Engineering	0.00 - 0.05						
Civil Engineering	0.00 - 0.05						
Vertical Transportation	0.00 - 0.03						
Flood Mitigation Design	0.00 - 0.03						
AV/IT Design	0.00 - 0.02						
Security Design	0.00 - 0.02						
Lighting Design	0.00 - 0.02						
Acoustic Design	0.00 - 0.02						
Shielding Design	0.00 - 0.02						
CON Services	0.00 - 0.02						
Each Additional Construction Phase	0.00 - 0.01						
Each Additional Bid Package	0.00 - 0.01						
Other	TBD						
Other	TBD						
Other	TBD						
SUB-TOTAL of Additional Services	-	0.00	0.00	0.00	0.00	0.00	
TOTAL Complexity Multiplier		0.00	0.00	0.00	0.00	0.00	

TABLE 5 - COMPENSATION PER PHASE			
Compensation shall be by phase as follows per the Standard Master Owner – Architect Agreement or as amended per Services Order:			
- Site Investigation, Analysis & Feasibility:	5%	- Construction Documents Phase:	35%
- Schematic Design Phase:	10%	- Bidding and Negotiation Phase:	5%
- Design Development Phase:	20%	- Construction Phase:	15%
		- Substantial Completion Phase:	5%
		- Close-Out Phase:	5%
			TOTAL Compensation 100%

COMMENTS
<p>Instructions: The Project Manager shall use the space below to:</p> <p>1) explain how the Complexity Multiplier was determined if not using the average complexity multiplier shown,</p> <p>2) provide a breakdown of any miscellaneous costs not represented by the Complexity Multiplier and,</p> <p>3) provide any other pertinent information.</p> <p>Text Here</p>

6. *Sample Calculations*

- **EXAMPLE 1 (Project Scope equal to standard Basic Services)** - Provide standard basic services for administrative offices inside an existing office building with a construction budget of \$10 million. In addition, the A/E Team shall perform a building analysis of existing MEP systems for \$20,000.

EXAMPLE 1 (Project Scope <u>equal to</u> standard Basic Services) – A/E FEE CALCULATOR					
Program Type <i>(based on Table 1)</i>	Program Type I	Program Type II	Program Type III	Program Type IV	Program Type V
Program Description	-	Office	-	-	-
Construction Budget	-	\$10,000,000	-	-	-
Fee Percentage <i>(automatically based on Table 2)</i>	0.00%	5.35%	0.00%	0.00%	0.00%
Complexity Multiplier <i>(1.0 or based on Table 4)</i>	-	1.00	-	-	-
SUB-TOTAL A/E Fee	\$0	\$535,000	\$0	\$0	\$0
Misc. A/E Fee Items <i>(items not included in the Complexity Multiplier)</i>	\$20,000				
TOTAL Maximum Allowable A/E Fee <i>(not including Reimbursables)</i>	\$555,000				

- **Fee Breakdown of Example 1**

Below is the fee breakdown of Example 1, itemized by phase in accordance with the Standard Master Owner – Architect Agreement:

Site Investigation, Analysis and Feasibility Phase	5%	\$ 27,750
Schematic Design Phase	10%	\$ 55,500
Design Development Phase	20%	\$111,000
Construction Documents Phase	35%	\$194,250
Bidding and Negotiation Phase	5%	\$ 27,750
Construction Phase	15%	\$ 83,250
Substantial Completion	5%	\$ 27,750
Close-Out Phase	5%	\$ 27,750
Total	100%	\$555,000

- **EXAMPLE 2 (Project Scope *less than* Basic Services)** - Provide A/E services to upgrade existing MEP systems in a Physicians' Practice (Article 28) in an existing facility with a construction budget of \$500,000. A/E services shall include limited Architectural services, full MEP / FP Engineering services and no structural, furniture or signage scope. The RED+F PM shall select Program Type IV and use a Complexity Multiplier of 0.60. (Limited Architectural services: 0.30; Full MEP / FP services: 0.30)

EXAMPLE 2 (Project Scope <i>less than</i> Basic Services) – A/E FEE CALCULATOR					
Program Type <i>(based on Table 1)</i>	Program Type I	Program Type II	Program Type III	Program Type IV	Program Type V
Program Description	-	-	-	Physician Practice (Article 28)	-
Construction Budget	-	-	-	\$500,000	-
Fee Percentage <i>(automatically based on Table 2)</i>	0.00%	0.00%	0.00%	11.40%	0.00%
Complexity Multiplier <i>(1.0 or based on Table 4)</i>	-	-	-	0.60	-
SUB-TOTAL A/E Fee	\$0	\$0	\$0	\$34,200	\$0
Misc. A/E Fee Items <i>(items not included in the Complexity Multiplier)</i>	-				
TOTAL A/E Fee Calculated <i>(not including Reimbursables)</i>	\$34,200				

- **Fee Breakdown of Example 2**

Below is the fee breakdown of Example 2, itemized by phase in accordance with the Standard Master Owner – Architect Agreement:

Site Investigation, Analysis and Feasibility Phase	5%	\$ 1,710
Schematic Design Phase	10%	\$ 3,420
Design Development Phase	20%	\$ 6,840
Construction Documents Phase	35%	\$11,970
Bidding and Negotiation Phase	5%	\$ 1,710
Construction Phase	15%	\$ 5,130
Substantial Completion	5%	\$ 1,710
Close-Out Phase	5%	\$ 1,710
Total	100%	\$34,200

- **EXAMPLE 3 (Project Scope *in excess* of Basic Services)** – Provide A/E services for a \$125 million mixed-use project consisting of a \$100 million freestanding hospital and a \$25 million administrative wing that will be brought on line in 2 phases. The A/E Team shall provide a variety of additional services for each program as described below. The RED+F PM shall sub-divide the project using the following Program Types and Complexity Multipliers:

- Hospital: \$100 million, Program Type V, Complexity Multiplier 1.10
(Full Basic Services: 1.0; AV/IT Design: 0.02; Security Design: 0.02; Lighting Design: 0.02; Acoustic Design: 0.02; and Shielding Design: 0.02)
- Admin. Wing: \$25 million, Program Type II, Complexity Multiplier 1.05
(Full Basic Services: 1.0; AV/IT Design: 0.02; Security Design: 0.02; 1 Additional Construction Phase: 0.01)

EXAMPLE 3 (Project Scope <i>in excess</i> of Basic Services) – A/E FEE CALCULATOR					
Program Type <i>(based on Table 1)</i>	Program Type I	Program Type II	Program Type III	Program Type IV	Program Type V
Program Description	-	Admin.	-	-	Hospital
Construction Budget	-	\$25,000,000	-	-	\$100,000,000
Fee Percentage <i>(automatically based on Table 2)</i>	0.00%	4.85%	0.00%	0.00%	5.35%
Complexity Multiplier <i>(1.0 or based on Table 4)</i>	-	1.05	-	-	1.10
SUB-TOTAL A/E Fee	\$0	\$1,273,125	\$0	\$0	\$5,885,000
Misc. A/E Fee Items <i>(items not included in the Complexity Multiplier)</i>	-				
TOTAL A/E Fee Calculated <i>(not including Reimbursables)</i>	\$7,158,125				

- **Fee Breakdown of Example 3**

Below is the fee breakdown of Example 3, itemized by phase in accordance with the Standard Master Owner – Architect Agreement:

Site Investigation, Analysis and Feasibility Phase	5%	\$ 357,906
Schematic Design Phase	10%	\$ 715,813
Design Development Phase	20%	\$1,431,625
Construction Documents Phase	35%	\$2,505,344
Bidding and Negotiation Phase	5%	\$ 357,906
Construction Phase	15%	\$1,073,719
Substantial Completion	5%	\$ 357,906
Close-Out Phase	5%	\$ 357,906
Total	100%	\$7,158,125

PROJECT DELIVERY PROCESS

RED+F's project delivery process falls into three major categories: formulation and planning; design; and construction.

Typically, projects are formulated for approval and are then guided through Design and Construction by an assigned NYU Langone project manager (RED+F PM) who follows a defined process to formulate and implement construction projects based on a specified scope, schedule and budget to meet the goals and needs of all stakeholders.

1. *Formulation & Planning*

- **Formulation** - To ensure that NYU Langone Health's resources are utilized in the most effective manner, most projects are initiated through Senior Administration. Individual departments can also initiate small department-funded projects by contacting RED+F directly. These requests are then reviewed by Senior Administration and, if approved, authorized to proceed. Requests are evaluated based on their importance in supporting NYU Langone Health's vision and strategic goals, space requirements, staffing requirements, potential impact on other programs, and funding sources.
- **Planning** - If Senior Administration determines a requested project merits further investigation, RED+F will do a planning study to identify the project objectives, scope, budget and schedule requirements. This is an iterative process, which attempts to balance project requirements with available resources. Throughout this process, RED+F provides professional assistance to define the primary objective of the project, the specific needs of the user department and the potential solutions.

Working with Senior Administration, RED+F then analyzes the options in a campus-wide context and establishes target budgets. By identifying key relationships, such as adjacencies to public spaces, utility connections, and potential future uses of the site, broad facility issues can be addressed one project at a time. The best options are re-examined and re-analyzed until a viable solution is found.

For major projects, RED+F will often contract outside consulting firms to work with the user-group through a process of defining the project goals, developing the space program, identifying and analyzing options, and budgeting. Throughout this process, RED+F will review the progress with Senior Administration. At the conclusion of the planning study, a formal report is prepared to document the project scope, budget, and schedule for approval by Senior Administration.

For small projects, the planning process is similar, but usually less complex and without the involvement of outside consultants.

- **Approvals** - During the Formulation Process, RED+F develops a clear statement of project objectives. This statement is incorporated into a final report along with the space program, schedule, and project budget for approval by Senior Administration and to serve as a guide throughout the design process.

All projects move through an approval process to ensure that NYU Langone Health's resources are managed effectively. The parties involved in the approval process and the number of approvals required varies depending on the project category, the size of the budget, and other considerations.

As projects are planned, they are incorporated into a comprehensive capital plan, either as a specific line item or as a broad allowance (pools). The capital plan is developed within the framework of a long-term financial plan. Both the capital plan and the financial plan are updated regularly to ensure that the future costs of any planned capital investments are accounted for in the long-term financial plan.

As projects become more defined, capital and operating budget implications are considered and the capital and financial plans are updated, reviewed and prioritized by NYU Langone Senior Leadership and approved by NYU Langone Health's Finance Committee. The planning studies prepared in the previous phase not only identify each project's objective, scope, budget, and schedule, but they also include a Project Authorization Form with signature lines for each of the parties responsible for approval. When all signatures on the form are received the project account is established and the design process begins.

2. *Design Phase*

Once approved, a NYU Langone project manager (RED+F PM) is assigned to the project and a project user-group is established. Starting with a design kick-off meeting, the PM coordinates a series of meetings with the Users and the Project Team to gather information. This group – comprising representatives from users, the Design Studio, Facilities Management, MCIT, Senior Administration, architectural and engineering consultants, and the construction manager, if applicable – will guide the project through planning and design. Its meetings provide a forum for coordination of the various aspects of the project during the design process.

- ***Schematic Design (SD)*** - This first phase of the design process defines the design parameters and the overall layout. The A/E Team generates schemes based on information gathered from a field investigation (documenting existing conditions) as well as from Users. The PM brings in other NYULH departments (Design Studio, Facilities, MCIT, Infection Prevention and Control, EH&S, Security, etc.) to help inform the design from their perspectives. Schemes are reviewed by all stakeholders and refined accordingly.

An estimate will be prepared at the end of this preliminary design phase to verify that the project remains within budget. The budget must be reconciled with scope prior to proceeding with the next phase of design.

A/E Deliverables:

- Meeting Minutes
- Schedule
- Cost Estimate
- Outline BIM Execution Plan (*if applicable*)

- Feasibility Studies
 - Outline Program Analysis
 - Outline Scope Narrative (incl. user requirements such as storage needs, etc.)
 - Outline “Basis of Design” document
 - SD Drawings:
 - Demolition Plans
 - Floor Plans (w/ FFE, material notes, etc.)
 - Elevations
 - CAD Renderings of major spaces
 - MEP/FP schematic drawings (single line acceptable)
 - Structural schematic drawings (i.e. primary structural system)
 - Sample materials
 - Outline Equipment List
 - Outline architectural and engineering specifications
- ***Design Development (DD)*** - In this phase, the layout agreed upon in preliminary design is developed in greater detail with all major components of the project defined and developed. There is often heavy User involvement to be sure that the design adheres to their needs. The PM brings in other NYU Langone Health departments (Design Studio, Facilities, MCIT, Infection Prevention and Control, EH&S, Security, etc.) to help inform the design from their perspectives. All key design decisions are made and agreed upon by the end of this phase.

The PM works with the A/E Team to keep scope in line with what was initially approved, with the addition of any changes incorporated during preliminary design. The PM must approve any changes to the agreed upon and authorized scope of the project as such changes would have impacts on the project budget.

An estimate is prepared at the end of the Design Development phase and the budget must be reconciled with the project scope prior to proceeding with the next phase. In addition, the User must sign-off on the floor plan(s) in a timely manner in order for the A/E Team to proceed into the Construction Document phase and maintain the overall project schedule.

A/E Deliverables:

- Meeting Minutes
- Schedule
- Cost Estimate
- Updated BIM Execution Plan (*if applicable*)
- Final Program Analysis
- Final Scope Narrative (incl. user requirements such as storage needs, etc.)
- Updated “Basis of Design” document
- DD Drawings:
 - Floor Plans (w/ FFE, dimensions, partition tags, RED+F room numbers, etc.)
 - Enlarged Floor Plans (of typical and major spaces)
 - Reflected Ceiling Plans
 - Elevations

- Sections
 - Schedules (i.e. Room Finish, Furniture, Door, Door Hardware, Lighting, Plumbing Fixture, Toilet Accessory, Building Accessory, Pantry Appliance, etc.)
 - Typical and Major Details (i.e. building envelope, lobby / reception, millwork, etc.)
 - CAD Renderings of major spaces
 - MEP/FP DD drawings (including double line HVAC drawings and riser diagrams)
 - Structural DD drawings (including typical details)
 - Signage and Wayfinding package including a list of all applicable codes, list of assumptions and observations, location plans (including locations of brand/donor related signage), message schedule (including room and wayfinding signage, recycling posters and decals, code required emergency/egress signage, health/safety signage, etc.) and simple elevation renderings for “high-profile” sign types. “High-profile” sign types shall include brand/donor related signage such as:
 - Building ID Branding/Recognition
 - Canopy Signage/Recognition
 - Building Entry Signage/Recognition
 - Main Lobby Recognition
 - Floor Recognition
 - Departmental Recognition
 - Waiting Area Recognition
 - Staging/phasing plans (*if applicable*)
 - Updated sample materials
 - Finish and Furniture Booklets
 - Updated Equipment List
 - Updated architectural and engineering specifications
 - Outline List of Special Inspections or Testing required by the Building Code
- **Construction Documents (CD)** - This phase takes the design as developed and finalized during Design Development and documents it for construction. Details are further refined as construction issues are addressed. The main emphasis of this phase is to verify that all needed information is on the drawings and in the specifications so that the project can be bid for construction. Typically, there are fewer meetings in this phase that require the involvement of the Users, as the emphasis is documentation of earlier design decisions.

Again, previously agreed upon and authorized scope, schedule and budget must be adhered to, and the Project Manager works with the A/E Team to keep scope in line, taking into account any changes incorporated during previous phases. At the end of this phase the Project Manager puts the project out to bid.

A/E Deliverables:

- Meeting Minutes
- Schedule
- Cost Estimate
- Final BIM Execution Plan (*if applicable*)
- Final “Basis of Design” document

- CD Drawings:
 - Floor Plans (fully developed and coordinated)
 - Enlarged Floor Plans (of typical and major spaces)
 - Reflected Ceiling Plans
 - Elevations
 - Sections
 - Schedules (i.e. Room Finish, Furniture, Door, Door Hardware, Lighting, Plumbing Fixture, Toilet Accessory, Building Accessory, etc.)
 - All details (fully developed)
 - CAD Renderings of major spaces
 - MEP/FP construction drawings (fully developed and coordinated)
 - Structural construction drawings (fully developed and coordinated)
 - Final Signage and Wayfinding package including list of all applicable codes, final Room Numbering Plan issued by the Space Planning and Management group, location plans, message schedule (including room and wayfinding signage, recycling posters and decals, code required emergency/egress signage, health/safety, etc.), signage quantity list, typical and major details/elevations and specifications.
 - Donor Opportunity package (*if applicable*) including a donor opportunity schedule, location plans, elevations, details and perspective renderings. The donor opportunity schedule shall be broken down by floor, room type / name with corresponding sign location tag and fundraising tiers as shown below:
 - Tier 1: Building
 - Tier 2: Floor
 - Tier 3: Department / Unit
 - Tier 4: Large Area / Room
 - Tier 5: Small Area / Room
 - Construction and Demolition Waste Management Plan (*if applicable*)
 - Final staging/phasing plans (*if applicable*)
 - Addendums issued prior to bidding
- Final sample materials
- Final Finish and Furniture Booklets
- Final Equipment List
- Final architectural and engineering specifications
- Final List of Special Inspections or Testing required by the Building Code

3. Construction Phase

After the Design phase the Project Manager coordinates construction of the project according to the construction drawings and specifications set by the Contract Documents. Project Managers have expertise in architecture, engineering, design and construction to bring capital construction and renovation projects forward from design to completion and occupancy.

- **Bidding and Negotiation (B/N)** - As a given project moves from development to the construction phase, the Project Manager initiates and oversees the bidding and negotiation procedure, forwarding contract documents to a list of pre-qualified contractors to solicit bids. During the ensuing bid period, the Project Manager and a

consulting team (typically an architect and engineer) answer questions raised by bidders, making sure all bidders are aware of all questions asked and answered.

At the end of bidding, contractors submit their proposed prices in sealed bids. Once the bids are opened, a leveling process ensues – a critical part of the process; leveling vets out discrepancies among bids to ensure an “apples to apples” comparison.

A/E Deliverables:

- Meeting Minutes
 - Participation in Pre-Bid Conferences and Site Walkthroughs
 - Bid Documents (Instructions to Bidders, Bid Form, Drawings and Specifications)
 - Written RFI Responses
 - Review and Approval of product substitution(s), “or equal” product(s)
 - Bid Leveling and Evaluation
 - Assist with bid negotiations and bidder selection
 - Final Construction Documents (including supplemental Addendums issued prior to award of construction contract)
- **Construction Administration (CA)** - Once leveling is completed, the project is awarded to the qualified bidder with the lowest bid, and a contract sets an agreed upon price for the work and commits the winning contractor to the authorized scope, schedule and budget. Starting with a construction kick-off meeting and continuing through the life of the project, the Project Manager sets goals and continually reviews the progress of construction with a focus on maintaining schedule and budget.

During construction, the Project Manager also orchestrates the coordination required with all other team members and organizations with ancillary project responsibilities, such as the Design Studio, Facilities, IT, Environmental Health & Safety, Radiation Safety, Infection Prevention and Control, Life Safety, Clinical Engineering and Security; as well as interior designers and other specialty consultants.

During this phase the A/E Team is responsible for helping the Contractor build the project as specified in the NYU Langone-approved Construction Documents. This is done through coordination with NYU Langone and the builder, inspection of physical “as-built” conditions and review of project documents prepared by the Contractor.

A/E Deliverables:

- Meeting Minutes, when deemed necessary
 - Attendance at Regular Job Progress Meetings
 - Visual inspection of construction work
 - Written report to document deficiencies, quality and quantity of work inspected
 - Recommendation to reject work not in compliance with Construction Documents
 - Direct minor changes in construction work
 - Written RFI Responses or Change Directives
 - Shop Drawing Review and Approval
- (Note: Refer to the Design Review Process subsection of these Design Guidelines for additional information.)*

- Review and Approval of material sample(s)
(Note: Refer to the Design Review Process subsection of these Design Guidelines for additional information.)
 - Review and Approval of product substitution(s), “or equal” product(s)
(Note: Substitutions require prior approval from RED+F’s Design Studio)
 - CA Drawings:
 - Bulletins issued after award of construction contract (including supplemental or revised drawings, specifications, sketches and other documents issued during construction)
 - Final “as-built” drawings received from contractor
 - Updated BIM model and Construction Documents reflecting construction related design changes w/ respect to floor plans, RCPs, Structural and MEP/FP field changes
 - Recommendation of testing and inspection laboratories or consultants
 - Maintenance and operating instructions and manuals, equipment manuals, warranties, guarantees, certificates of inspection, test results, approvals and related documents, and all other Construction Contract close-out documents
 - Review and Recommendation regarding Change Order Proposals
 - Review of Contractor’s Applications for Payment
 - Issuance of Certificates of Payment, as appropriate
 - Sign-Off as required by Regulatory Agencies
 - Preparation or, if prepared by others, review and approval of punch lists
 - Inspection of the project to determine substantial completion
 - Substantial Completion Checklist
 - Certificate of Substantial Completion with punch lists and list of acceptable non-conforming work attached, if appropriate
- **Close-Out (CO)** - Once the project is completed, the Project Manager initiates the closeout procedure, makes certain that all installed components are operating as specified, and the newly opened facility project performs as designed.

During this phase the A/E Team is responsible for bringing the project to closure ensuring that all deliverables are in compliance with the Contract Documents, all necessary documents (such as equipment manuals, warranties, guarantees, etc.) have been delivered to NYU Langone Health, all required regulatory sign-offs have been obtained, all punch list items are completed to the satisfaction of NYU Langone Health, and final payment request has been reviewed and approved.

A/E Deliverables:

- Participation in Project Close-Out Meeting
- Close-Out Drawings:
 - Filing of amended Construction Documents with DOB and other authorities having jurisdiction
 - “Final record drawings” incorporating all design changes subsequent to issuance of the Construction Documents.
- As-Built “Basis of Design” document
- As-Built Finish and Furniture Booklets

- Finish Photography
 - Complete sets of regulatory approvals
 - Maintenance/cleaning and operating instructions and manuals, equipment manuals, warranties, guarantees, certificates of inspection, test results, approvals and related documents, and all other Construction Contract close-out documents.
 - Completion of Substantial Completion and Project Close-Out Checklists (refer to the Close-Out Package subsection of these Design Guidelines)
 - Inspection of the project to determine final completion
 - Issuance of the Certificate of Final Completion
 - Review and Approval of final payment to contractor
4. To assist the A/E Team, below is a summary of A/E Deliverables for the Design Phases [Schematic Design (SD), Design Development (DD) and Construction Documents (CD)]:

A/E DELIVERABLES for the DESIGN PHASES	PHASE		
	SD	DD	CD
Project Documentation			
Meeting Minutes	✓	✓	✓
Schedule	✓	✓	✓
Cost Estimate	✓	✓	✓
BIM Execution Plan (<i>if applicable</i>)	Outline	Updated	Final
Feasibility Studies	✓		
Program Analysis	Outline	Final	
Scope Narrative (incl. user requirements such as storage needs, etc.)	Outline	Final	
“Basis of Design” document	Outline	Updated	Final
List of Special Inspections or Testing required by the Building Code		Outline	Final
Drawings			
Architectural drawings			
Demolition plans	✓		
Floor plans (w/ FFE, material notes, etc.)	✓		
Floor Plans (w/ FFE, dimensions, partition tags, RED+F room #s, etc.)		✓	
Floor Plans (fully developed and coordinated)			✓
Enlarged Floor Plans (of typical and major spaces)		✓	✓
Reflected Ceiling Plans		✓	✓
Elevations	✓	✓	✓
Sections		✓	✓
Schedules (i.e. Room Finish, Furniture, Door, Door Hardware, Lighting, Plumbing Fixture, Toilet Accessory, etc.)		✓	✓
Typical and Major Details		✓	
All details (fully developed)			✓
CAD Renderings of major spaces	✓	✓	✓
MEP/FP drawings			
Schematic drawings (single line acceptable)	✓		
DD drawings (incl. double line HVAC drawings and riser diagrams)		✓	
Construction drawings (fully developed and coordinated)			✓
Structural drawings			
Schematic drawings (i.e. primary structural system)	✓		
DD drawings (incl. typical details)		✓	
Construction drawings (fully developed and coordinated)			✓

A/E DELIVERABLES for the DESIGN PHASES (CONT'D)	PHASE		
	SD	DD	CD
Drawings (cont'd)			
Signage & Wayfinding package			
incl. list of all applicable codes, list of assumptions and observations, location plans (including locations of brand/donor related signage), message schedule, simple elevation renderings for “high profile” sign types		✓	
incl. list of all applicable codes, final Room Numbering Plan issued by SPM group, location plans, message schedule, signage quantity list, details/elevations and specifications			✓
Donor Opportunity Package (<i>if applicable</i>) including a donor opportunity schedule, location plans, elevations, details and perspective renderings.			✓
Construction and Demolition Waste Management Plan (<i>if applicable</i>)			✓
Staging/Phasing plans (<i>if applicable</i>)		Outline	Final
Addendums (<i>issued prior to bidding</i>)			✓
Specifications			
Sample materials	Outline	Updated	Final
Finish and Furniture Booklets		Outline	Final
Equipment List	Outline	Updated	Final
Architectural and Engineering specifications	Outline	Updated	Final

5. To assist the A/E Team, below is a summary of A/E Deliverables for the Construction Phases [Bidding and Negotiation (B/N), Construction Administration (CA) and Close-Out (CO)]:

A/E DELIVERABLES for the CONSTRUCTION PHASES	PHASE		
	B/N	CA	CO
Project Documentation			
Meeting Minutes, when deemed necessary	✓	✓	
Participation in Pre-Bid Conferences and Site Walkthroughs	✓		
Written RFI Responses	✓		
Bid Leveling and Evaluation	✓		
Assist with bid negotiations and bidder selection	✓		
Attendance at Regular Job Progress Meetings		✓	
Visual inspection of construction work		✓	
Written report to document deficiencies, quality and quantity of work inspected		✓	
Recommendation to reject work not in compliance with Construction Documents		✓	
Direct minor changes in construction work		✓	
Written RFI responses or Change Directives		✓	
Recommendation of testing and inspection laboratories or consultants		✓	
Maintenance and operating instructions and manuals, equipment manuals, warranties, guarantees, certificates of inspection, test results, approvals and related documents, and all other Construction Contract close-out documents		✓	✓
Review and Recommendation regarding Change Order Proposals		✓	
Review of Contractor’s Applications for Payment		✓	
Issuance of Certificates of Payment, as appropriate		✓	
Sign-Off as required by Regulatory Agencies		✓	
Preparation or, if prepared by others, review and approval of punch lists		✓	

A/E DELIVERABLES for the CONSTRUCTION PHASES (CONT'D)	PHASE		
	B/N	CA	CO
Project Documentation (cont'd)			
Inspection of the project to determine substantial completion		✓	
Substantial Completion Checklist		✓	
Certificate of Substantial Completion with punch lists and list of acceptable non-conforming work attached, if appropriate		✓	
Participation in Project Close-Out Meeting			✓
As-Built "Basis of Design" document			✓
As-Built Finish and Furniture Booklets			✓
Finish Photography			✓
Complete sets of regulatory approvals			✓
Completion of Substantial Completion and Project Close-Out Checklists			✓
Inspection of project to determine final completion			✓
Issuance of the Certificate of Final Completion			✓
Review and Approval of final payment to contractor			✓
Drawings			
Bid Documents (Instructions to Bidders, Bid Form, Drawings and Specifications)	✓		
Final Construction Documents (incl. supplemental Addendums issued prior to award of construction contract)	✓		
Bulletins issued after award of construction contract (incl. supplemental or revised drawings, specifications, sketches and other documents issued during construction)		✓	
Final "as-built" drawings received from contractor		✓	
Updated BIM model and Construction Documents reflecting construction related design changes w/ respect to floor plans, RCPs, Structural and MEP/FP field changes		✓	
Filing of amended Construction Documents with DOB and other authorities having jurisdiction			✓
"Final record drawings" incorporating all design changes subsequent to issuance of the Construction Documents			✓
Specifications			
Review and Approval of product substitution(s), "or equal" product(s) [Note: Substitutions require prior approval from RED+F's Design Studio]	✓	✓	
Shop Drawing Review and Approval		✓	
Review and Approval of material sample(s)		✓	

BASIS OF DESIGN

The Basis of Design report shall be a word document providing general project information including a project narrative, specific applicable codes, as well as architectural, structural and MEP/FP narratives. This document shall be submitted by the A/E Team as part of Schematic Design, Design Development and the Construction Document phases. It shall also be included in the “As-Built” package at the end of the Construction Administration phase. The purpose of the Basis of Design report is to ensure that the owner and consultants have agreed to the scope and code interpretations in a clear and succinct manner.

The following shall be included in the Basis of Design report:

1. *Cover Page*
 - Title: Basis of Design Report
 - Project Name:
 - PIM #:
 - Prepared by:
 - Date and Rev #:
2. *Table of Contents*
3. *Project Narrative*
 - Project name
 - Location and size
 - Type of project (renovation or new construction)
 - Consultant Team Information (i.e. Architect of Record, Engineer(s) of Record, Specialty Consultants, etc.)
4. *Applicable codes*
 - List of all applicable codes and specific code requirements
5. *Architectural Narrative*
 - Brief description of architectural design and finishes used.
 - Program which includes the list of spaces and square footages
6. *Structural Narrative*
 - Brief description of structural systems for the foundation, floor, columns and roofs.
7. *MEP/FP Narrative*
 - Brief description of the systems for HVAC, Electrical, Plumbing and Fire Protection.
8. *Sustainability Narrative*
 - Brief description of the project’s environmental and sustainability goals and the methods that will be used to meet them.

Each revision shall be dated. All changes shall be tracked to compare the current revised version to the previous version.

DESIGN REVIEW PROCESS

The Design Studio at RED+F provides architectural and interior design review on capital projects throughout NYU Langone Health. The studio’s goal is to ensure projects are designed, detailed and built in conformance with NYU Langone’s mission devoted to excellence in patient care, education, and research and comply with our Design Principles as outlined in these Design Guidelines:

- Design Quality
- Construction Quality
- Cost Effectiveness
- Schedule Compliance
- Design Flexibility
- Efficient, Functional and Practical
- Intuitive Wayfinding
- Durable Materials
- Attention to Details
- Collaborative Process

The information provided in this subsection includes:

1. Design Studio Involvement per Phase
2. Design Studio, PM and A/E Team Meeting(s)
3. Design Review Meeting(s) with the EVP/VD of RED+F

1. Design Studio Involvement per Phase

The RED+F Design Studio is comprised of four groups: Architecture, Interior/Furniture, Signage/Wayfinding and Art. Each group will provide feedback at certain phases. Below is a list of the groups’ involvement per phase:

Phase	Architecture Group	Interior/Furniture Group	Signage/Wayfinding Group	Art Group
SD	✓	✓	✓	✓
DD	✓	✓	✓	✓
CD	✓	✓	✓	✓
B/N		✓	✓	✓
CA	✓	✓	✓	✓

Legend:

- SD = Schematic Design
- DD = Design Development
- CD = Construction Documents
- B/N = Bidding and Negotiation
- CA = Construction Administration

2. *Design Studio, PM and A/E Team Meeting(s)*

The number of design meetings between the A/E Team, PM and the RED+F Design Studio will depend on the size and complexity of the project and how properly the A/E Team develops a project in accordance with the design direction provided. The Design Studio shall receive a half-size set of the drawings after each phase. The following describes design issues the Design Studio will opine on per phase.

▪ *Kick-Off*

The RED+F PM will schedule a separate meeting with the Design Studio at the start of the project and provide the following information. Please note, the Design Studio cannot assist until this information is provided:

- Project Name and Address
- PIM number
- Scope of the project (program/department, phasing, existing conditions, etc.)
- Budgets for Furniture, Signage and Art
- Schedule

▪ *Schematic Design*

- Review the basic plan organization (parti).
- Review the plans and RCP.
- Discuss basic material and furniture types that should be considered.

▪ *Design Development*

Architecture Group:

- Finalize the plan's organization and confirm it is developing properly.
- Review the plan, RCP, elevations, sections, schedules (including plumbing fixtures, toilet accessories, building accessories, and pantry appliances), and typical and major details.
- Review the proposed materials to confirm they are reinforcing the parti.
- Review waste management processes and products (including recycling receptacles).

Interior/Furniture Group:

- Discuss budget and phasing with PM.
- Provide a list of FF&E items to be salvaged for reuse, recycled or sent back to the manufacturer.
- Review the furniture layouts (including recycling receptacles). After the A/E Team has finalized their furniture layout, the CAD files will be sent to an approved furniture vendor. The furniture vendor will draw up the actual furniture pieces in the floor plan and send back to the A/E Team.
- Review the proposed materials to confirm they are reinforcing the parti.

Signage/Wayfinding Group:

- Discuss budget with PM.
- Provide a list of existing signage to be salvaged for reuse.
- Discuss the approach and process for signage design and procurement.

- Review Signage and Wayfinding package including:
 - location plans,
 - branding,
 - room numbering system,
 - message schedule (including room and wayfinding signage, recycling posters and decals, code required emergency/egress signage, etc.)
 - digital signage, and atypical signage.

Art Group:

- Discuss budget with PM.
- Provide a list of existing art to be salvaged for reuse.
- Discuss locations for the owner selected art.
- Coordinate lighting.
- Confirm electrical devices (i.e. light switches, fire strobes, thermostats, electrical outlets, telephone/data outlets, etc.), room and directional signage, and furniture are not blocking art locations.

■ **Construction Documents**

Architecture Group:

- Finalize the plan, RCP, elevations, sections, schedules (including plumbing fixtures, toilet accessories, building accessories, and pantry appliances), and typical and major details (including millwork details).
- Finalize material selection in relation to the parti.
- Review any modifications to the architecture due to the final furniture layout.
- Finalize waste management processes and products (including recycling receptacles).

Interior/Furniture Group:

- Finalize budget and phasing with PM.
- Review final furniture layout (including recycling receptacles).
- Finalize material selection in relation to the parti.
- Review any modifications to the architecture due to the final furniture layout.

Signage/Wayfinding Group:

- Finalize budget with PM.
- Review final Signage and Wayfinding package including final Room Numbering Plan issued by the Space Planning and Management group, location plans, message schedule (including room and wayfinding signage, recycling posters and decals, code required emergency/egress signage, etc.), typical and major elevations/details, and specifications.
- Review Donor Opportunity package (*if applicable*) including a donor opportunity schedule, location plans, elevations, details and perspective renderings.

Art Group:

- Finalize budget with PM.
- Finalize locations for the owner selected art.
- Finalize lighting.

- Finalize locations of electrical devices (i.e. light switches, fire strobes, thermostats, electrical outlets, telephone/data outlets, etc.), room and directional signage, and furniture are not blocking art locations.

- ***Construction Administration***

Architecture Group:

- Review any design related issues during the CA phase.
- Review shop drawings for plumbing fixtures, toilet accessories, building accessories, pantry appliances, recycling and millwork.
- Review and approval of product substitutions.
- Walk the construction site at appropriate intervals (50% sheetrock installed, 90% painting, 100% construction completion, Post-Occupancy review).
- Review punchlist submitted by Architect.

Interior/Furniture Group:

- Review furniture shop drawings for fabrication.
- Review material sample(s).
- Review and approval of product substitutions.
- Review furniture installation.
- Walk the construction site at appropriate intervals (50% sheetrock installed, 90% painting, 100% construction completion, Post-Occupancy review).
- Review punchlist submitted by Architect.

Signage/Wayfinding Group:

- Review signage shop drawings for fabrication.
- Review signage installation.
- Walk the construction site at appropriate intervals (50% sheetrock installed, 100% construction completion, Post-Occupancy review).
- Participate in punchlist walk-through with Architect. Review punchlist created / submitted by Architect.

Art Group:

- Coordinate art installation.
- Walk the construction site at appropriate intervals (50% sheetrock installed, 100% construction completion, Post-Occupancy review).

3. *Design Review Meeting(s) with the EVP of RED+F*

After a project has been vetted by the Design Studio the project will be reviewed by the Executive Vice President and Vice Dean of RED+F. The number of design presentations will depend on the size and complexity of the project and how properly the A/E Team develops a project in accordance with the design direction provided. A project may be reviewed once or several times. The project may be presented to the EVP/VD of RED+F either by the A/E Team or by the Design Studio. The Program Director and Senior Director of Design will determine how this will be presented on a case-by-case basis.

PRESENTATION MATERIALS

In communicating the design to NYU Langone Health, the A/E Team shall provide presentation materials that are clear and easy to understand. Plan Diagrams, Reflected Ceiling Plans (RCP), Material/Finish Diagrams, Material/Finish samples, Perspective Renderings, and Furniture cut sheets are to be presented during the design phases, with any additional or supplemental information as may be necessary to clearly communicate the quality of the space. Below are some examples of acceptable presentation materials:

1. Schematic Design Phase

- **Plan Diagrams** - Plan diagrams shall be presented to NYU Langone during the schematic design phase. Diagrams shall be labeled and color coded with a key. They shall convey the overall plan organization (parti), programmatic spaces, key features, circulation, and highlight natural light and views (inside and out). Below are acceptable examples:

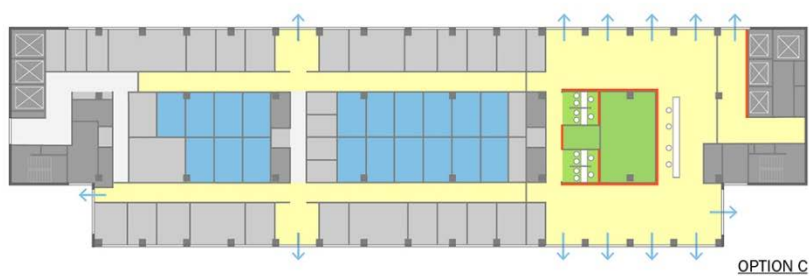
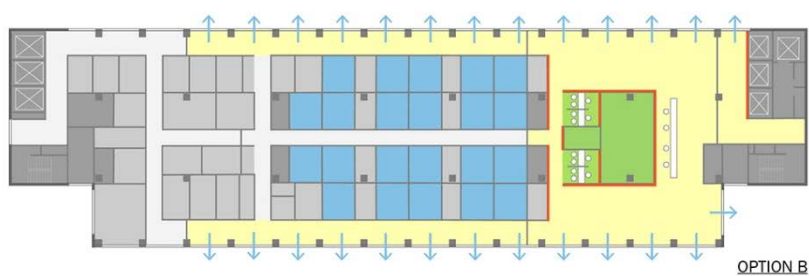
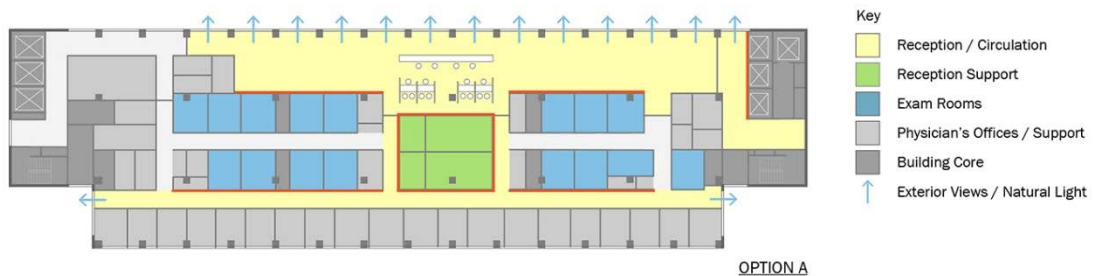

Plans: Ballinger

2. Design Development Phase

- Plan Diagrams - Plan diagrams shall be presented to NYU Langone during the design development phase. Rooms shall be labeled, furniture drawn, and the drawings shall be to a scale with a key designating the various materials. They shall be presented when materials and finishes are being reviewed. Below are acceptable examples:

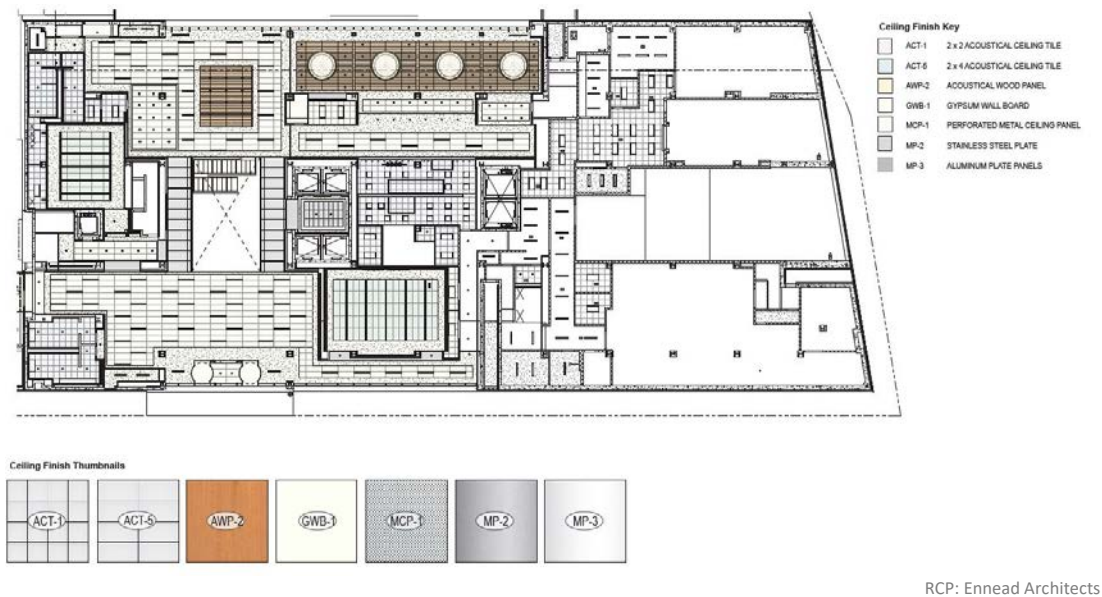
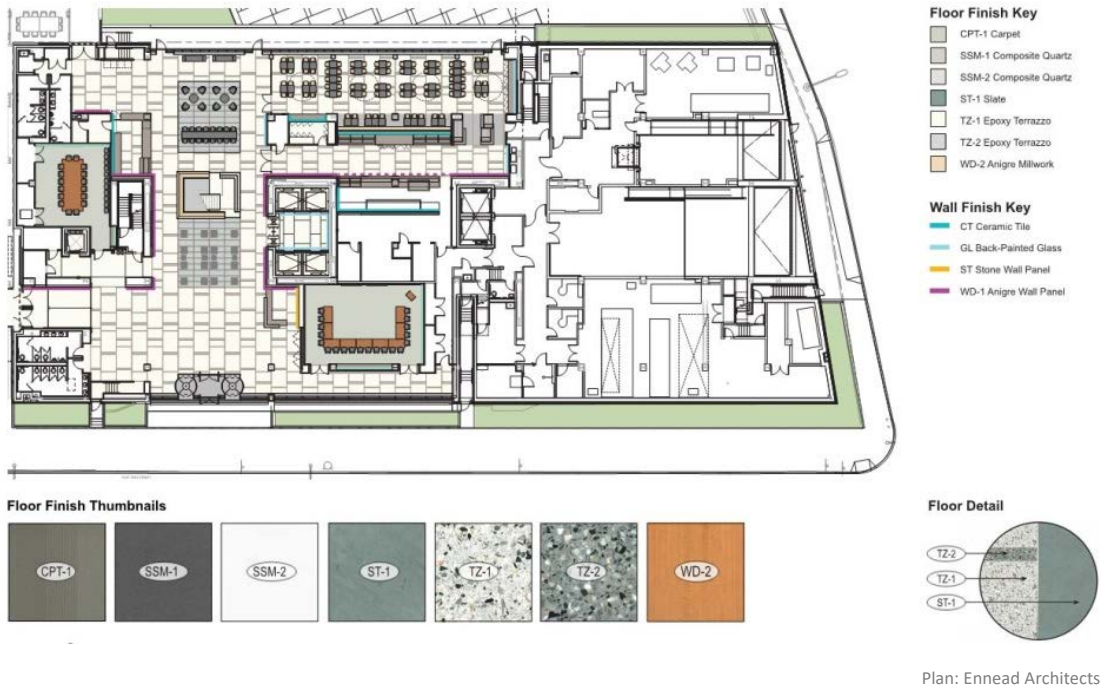

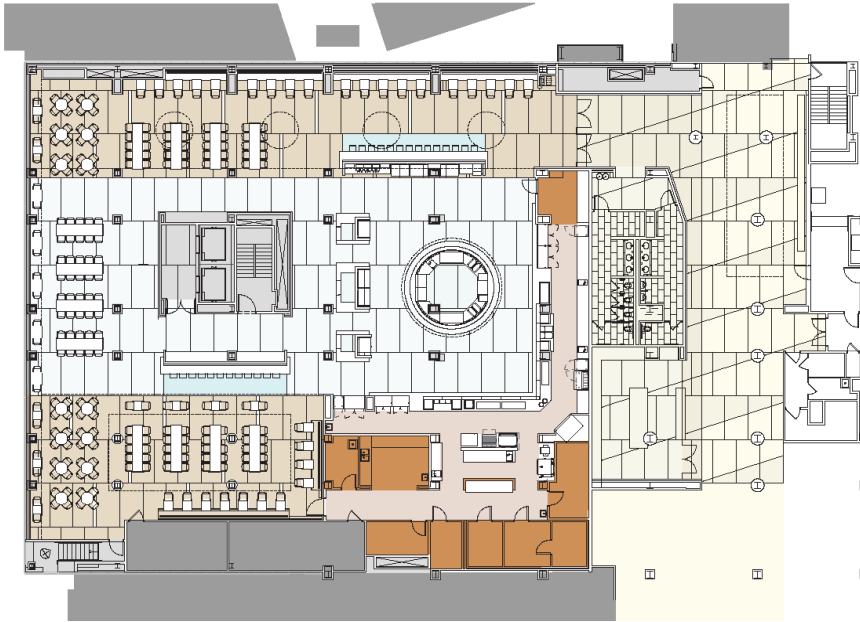

Plan: Ennead Architects

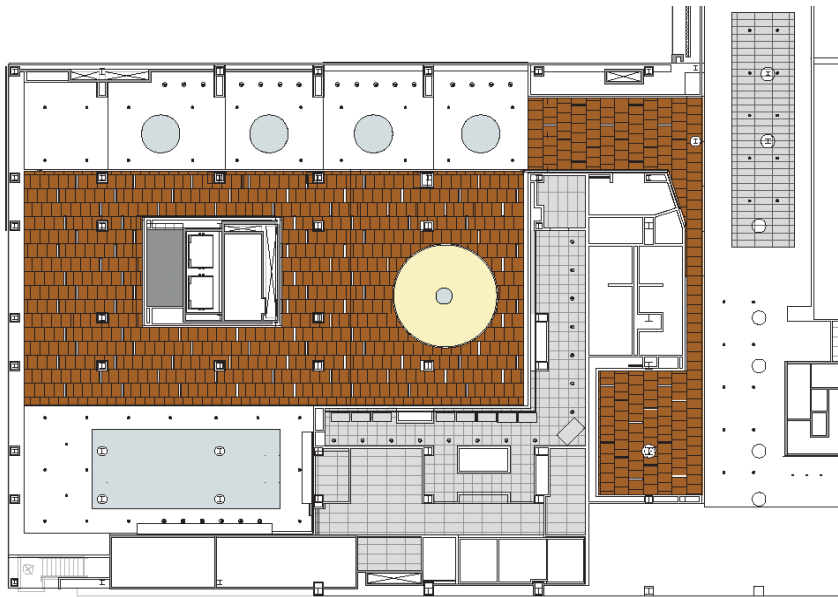

RCP: Ennead Architects

- Material/Finish Diagrams** - Finish Diagrams shall be presented to NYU Langone during the design development phase. The purpose is to clearly identify the locations of the various materials and finishes in the project. The drawing can be a plan or axonometric. The diagram should be color coded and have a key identifying the different materials and finishes. The actual material samples shall be presented simultaneously. Below are acceptable examples:

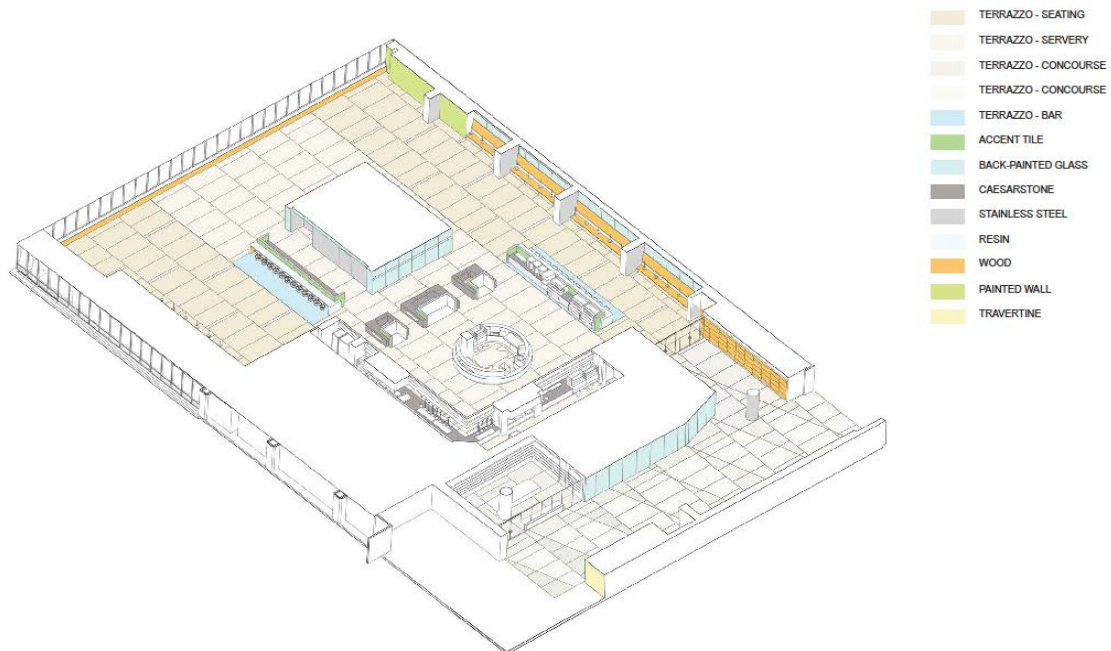
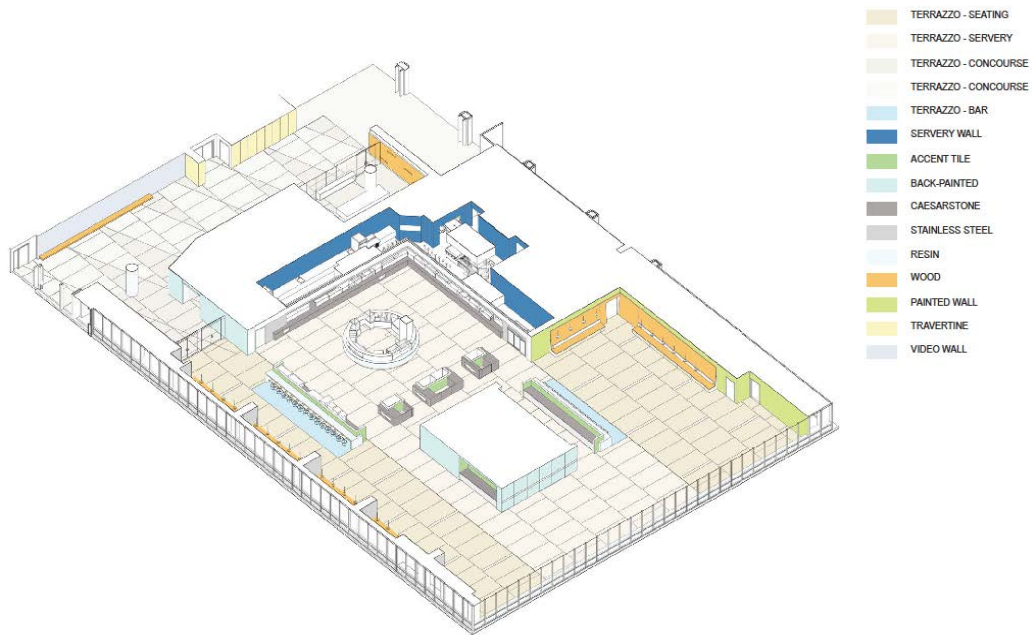

Ennead Architects

- Material/Finish Samples** - Actual samples of Materials/Finishes shall be presented to NYU Langone during the design development phase. The Architect shall provide sizes that are appropriate to both the scale and scope of the material in the project. For example, a large sample of the base color must be presented if it is being used in the majority of spaces. Samples such as wood and terrazzo shall be large enough to show the pattern, grain, color variation, etc. The materials should be keyed into the Finish Diagrams and/or Renderings. Below is an acceptable example:

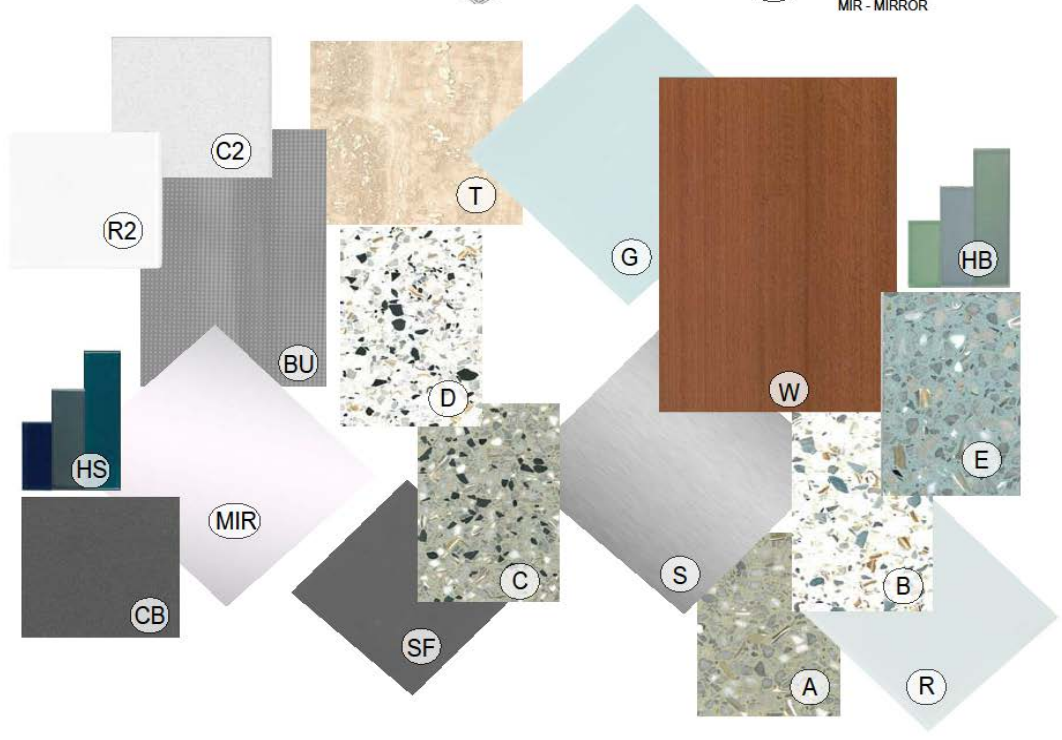
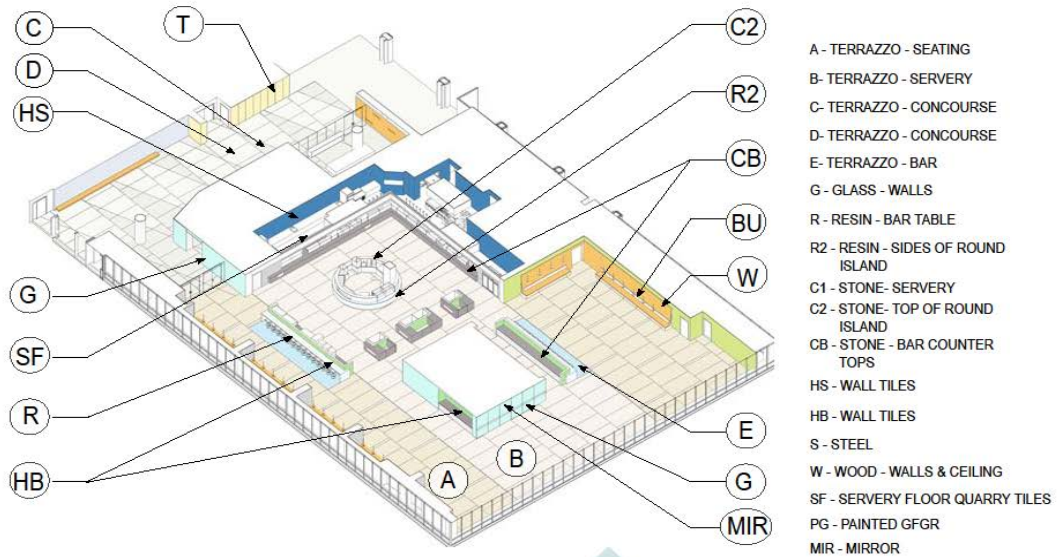

Ennead Architects

- Perspective Renderings** - CAD Perspective renderings shall be presented to NYU Langone during the design phases. The quality level shall be sufficient for NYU Langone to understand the scale, material, color and lighting of the space. Single line or freehand perspectives are to be used sparingly and only as additional or supplemental information. Below are acceptable examples of such renderings:



Ennead Architects



Ennead Architects

FINISH & FURNITURE BOOKLETS

The Architect shall submit to the RED+F Design Studio, a (1) Finish Booklet and a (2) Furniture Booklet using NYULH templates accessible on BuildFlow (the NYU Langone Health construction document management site). Each booklet shall be submitted in pdf format via BuildFlow at the end of Design Development, Construction Documents and as part of the project closeout.

1. *Finish Booklet Items* - The Finish booklet shall have finish floor plan(s), RCP(s), room finish schedule, as well as all project finish information. The Finish Booklet shall include information on the proposed / installed materials, including product name and number, color, finish, size, manufacturer, contact information, room/location, and any other pertinent information. The booklet shall follow the Room Finish and Material Legend subsections of these Design Guidelines as described below:

- Floors
- Base
- Walls
- Doors
- Ceilings
- Millwork
- Countertops
- Window Sills/Convectors
- Window Treatments/Curtains

2. *Format for the Finish Booklet* - Below is the format to be used for the Finish Booklet. The first pages of the Finish Booklet shall contain finish floor plan(s), RCP(s), and room finish schedule(s) for the project. This should be followed by the Material and Finish data on 8½” x 11” as formatted below.

FLOORS

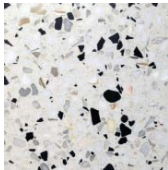
TERRAZZO	
TER-1	<p>Manufacturer: KrisStone</p> <p>Description: Thin-set epoxy custom mix with zinc dividers, KLLC1211E</p> <p>Thickness: 3/8”</p> <p>Contact:</p>
	



RESILIENT FLOORING: RESILIENT TILE			
RT-2	Manufacturer:	Nora	
	Product Style:	Nora Environcare	
	Product Color:	Lace Vine 2945	
	Size:	24" x 24"	
	Thickness:	2 mm thick	

BASE

WALL BASE			
RB-1	Manufacturer:	Johnsonite	
	Product Style:	Tightlock Cove Base, Resilient Floors	
	Product Color:	Pewter, 38	

WALLS

WALL TILE			
TILE-2	Manufacturer:	Nemo Tile	
	Product Style:	Embarcadero Porcelain	
	Product Color:	Mission Beige	
	Grout:	Laticrete Spectralock Pro, 23 Antique White	
	Size:	12" x 24"	
	Contact:	Nic Jennings njennings@nemotile.com/212-505-0009	
WALL COVERING			
WC-01	Manufacturer:	Carnegie Xorel	
	Product Style:	Strie W, 6423W	
	Product Color:	Color 136	
	Size:	Width: 52"	
	Contact:		

WALL PROTECTION			
CG-4	Manufacturer:	Construction Specialties, or approved	
	Product No.:	CO-8	
	Finish:	Stainless Steel	
	Legs:	2 ½"	
	Height:	Full height	
	Corner:	90 degree corners	
		Surface mounted	
HR-1	Manufacturer:	Construction Specialties, or approved	
	Product No.:	P-RWS	
	Finish:	Stainless Steel, Wood Handrail, stain to match WD-1	

DOORS

WOOD			
WD-1	Manufacturer:	Dooge Veneers Inc.	
	Product Color:	Anigre, Qtd Figured	
	Log No.:	#77/30 FSC, stained to match architect’s sample	

CEILINGS



ACOUSTICAL LAY-IN CEILINGS			
ACT-1	Manufacturer:	Armstrong	
	Product Style:	Healthzone Ultima	
	Product Color:	White	
	Size:	As Noted	

3. **Furniture Booklet Items** - The Furniture Booklet shall have tagged furniture plan(s), electrical plan(s), as well as all project furniture information. The Furniture Booklet shall include information on the proposed / installed furniture, including product name and number, color, finish, size, manufacturer, contact information, room/location, and any other pertinent information. The booklet shall follow the Furniture and Recycling Program subsections of these Design Guidelines as described below:
 - Casegoods
 - Work Stations
 - Tables
 - Seating
 - Storage
 - Accessories
 - Trash/Recycling Receptacles
 - Outdoor Furniture





4. **Format for the Furniture Booklet** - Below is the format to be used for the Furniture Booklet. The first pages of the Furniture Booklet shall contain tagged furniture plan(s) and electrical plan(s) of the project. This should be followed by the Furniture and Finish data on 8½” x 11” as formatted below.

WORKSTATIONS

WORKSTATION	
Tag:	WS-1STEELCASE
Manufacturer:	Universal
Product name:	Steelcase Established Textured Paint Fog 7236 (Metal)
Finish:	Steelcase Plain Jane Petosky 5F72 (Trackable)
Options/Remarks:	Reduced Pulls, Configuration Varies, See Plan
Location:	Typical Administrative Offices

TABLES

CONFERENCE TABLE	
Tag:	T-4BERNHARDT
Manufacturer:	Trace Table
Product name:	Oak 867
Finish:	n/a
Options/Remarks:	2 nd Floor Conference Room
Location:	
	
	
CREDENZA	
Tag:	ST-2
Manufacturer:	BERNHARDT
Product name:	Shift Credenza
Finish:	Oak 867
Options/Remarks:	Per NYU Standards
Location:	2 nd Floor Conference Room
	
	

SEATING

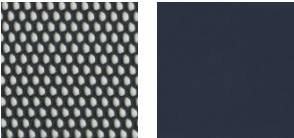

TASK CHAIR	
Tag:	CH-5
Manufacturer:	STEELCASE
Product name:	Think 3D Knit
Frame Color:	Black
Arm Cap:	Black
Options/Remarks:	n/a
Weight Capacity:	400 lbs.
Casters:	carpet
Upholstery (seat):	Mayer Durango Sapphire
Upholstery (back):	Steelcase 3D Knit Sailor
Location:	Reception Desks, Admin Offices, MA Stations
	
	

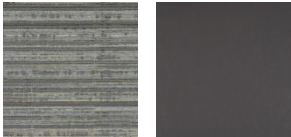
CONFERENCE CHAIR	
Tag:	CH-17
Manufacturer:	KEILHAUER
Product name:	Vanilla
Frame Color:	Chrome Frame
Arm Cap:	None
Options/Remarks:	n/a
Weight Capacity:	300 lbs.
Casters:	carpet
Upholstery (seat):	Maharam Article Storm
Upholstery (back):	Luum Line Language, Pigment
Location:	2 nd Floor Conference Room

TRASH/RECYCLING RECEPTACLES

FRONT-OF-HOUSE RECEPTACLES	
Tag:	TB-6
Manufacturer:	Nucraft
Product name:	Recycling Center
Finish:	Oak 867
Internal Rigid Liner(s):	By Manufacturer
Options:	Per NYU Standards
Location:	2 nd Floor Conference Room

CAD DOCUMENTATION STANDARDS

The Space Planning and Management group of RED+F is responsible for space reporting, assessment and planning for NYU Langone Health. In order to fulfill its responsibilities, the group maintains a space inventory of all owned and leased properties, comprising floor plans and usage information. To assure project teams are working with the latest drawings, the A/E Team shall request electronic drawing files from the space inventory directly from the Space Planning and Management group.

Keeping all floor plans and space information current is important to our operations. The RED+F PM and A/E Team involved in capital projects that impact the space inventory must provide appropriate documentation to the Space Planning and Management group in a timely manner. Drawings/Models shall be delivered to NYU Langone Health on the completion of each of the following phases: Schematic Design, Design Development, Construction Documents, and Construction Administration. Drawings showing as-built conditions shall be delivered as part of the Close-Out process upon construction completion.

1. *Mode of Delivery*

All project files shall be delivered via BuildFlow, the NYU Langone Health construction document management site.

2. *File Submission Requirements*

▪ *Drawing Files (.dwg)*

Drawings shall be delivered in DWG format. Each drawing file shall contain the drawing sheet(s) in AutoCAD Space Mode. All X-ref drawings shall be bound and inserted into the drawings. Files shall be uploaded individually into BuildFlow in DWG format. ZIP files will not be accepted.

All 3D and BIM drawings shall be exported from BIM in the *coarse view setting* to 2D-compatible DWG files. Prior to conversion, hatching shall be removed and material details shall be unchecked from the *materials view*.

The floor plans shall be delivered in their entirety. Partial or clipped floor plans will not be accepted.

▪ *Plotsheet Files (.dxf / .pdf)*

Plotsheet files should be generated out of the BIM and/or drawing files in DXF and/or PDF format.

3. File Standards

This subsection establishes the basic file standards and naming conventions that must be used when developing a project using Computer Aided Design (CAD) technology for NYU Langone Health.

- ***Project Identification Number***

Each project within NYU Langone Health is assigned a unique Project Identification Number, also referred to as the PIM #. At the inception of all projects, the A/E Team must obtain the NYU Langone project ID number from the RED+F Project Manager to support the proper naming of drawing/model files, content and other support files. The PIM # must appear clearly on the drawing sheet(s).

- ***Regulatory Agency Application Numbers***

The NYC Department of Buildings job number for projects in New York City or the equivalent for projects in municipalities outside of New York City must appear clearly on the drawing sheet(s).

- ***Discipline Codes***

All drawing/model files, content and support files shall be prefixed with the appropriate Discipline Code (D). Discipline codes in use by NYU Langone Health are in line with the national CAD standards. The most common are listed in the table below:

Code	Discipline Name	Code	Discipline Name
A	Architectural	L	Landscape
C	Civil	M	Mechanical
E	Electrical	P	Plumbing
FP	Fire Protection	S	Structural

- ***Drawing List Standards***

Drawing sets shall be organized as described below:

- A-000 General Information
- A-100 Floor Plans
- A-200 Elevations
- A-300 Exterior Details
- A-400 Interior Details
- A-500 Vertical Transportation
- A-600 Reflected Ceiling Plans
- A-700 Finish Plans
- A-800 Schedules

Note: Consultant drawings should follow the same format (i.e. M-000 General Information, M-100 Floor Plans, etc.).

- ***File Naming Standards***

All electronic project information should be named following the nomenclature outlined in these guidelines. This will ensure that projects can be accurately maintained during production, archived at each milestone and retrieved for future use.

- Drawing Files (.dwg)

Drawing Files should be named beginning with the Project Identification Number followed by a dash, the Sheet Number, underscore and the Sheet Name.

The filename should take the form of:

PIM#-Sheet Number_Sheet Name.format

As an example, an Architecture Drawing File would be named as follows:

10662-A-100_First Floor Plan.dwg

- Model Files (.rvt)

Model Files should be named beginning with the Project Identification Number followed by a dash, and a Discipline Code. If multiple models are being submitted for a single discipline you may use a level 2 designator as outlined in the national CAD standards.

The filename should take the form of:

PIM#-D.format

As an example, an Architecture Revit Model File would be named as follows:

10662-A.rvt

- Plotsheet Files (.dxf / .pdf)

Plotsheet Files should be named beginning with the Project Identification Number, followed by a dash, the Sheet Number, underscore and the Sheet Name.

The filename should take the form of:

PIM#-Sheet Number_Sheet Name.format

As an example, an Architecture Plotsheet File would be named as follows:

10662-A-100_First Floor Plan.dxf

10662-A-100_First Floor Plan.pdf

CAD LAYER STANDARDS					
Category	RED+F Layer Name	Description	RED+F CAD Color	RED+F CAD Lineweight	RED+F CAD Linetype
Architectural	A-CURB	Curbs for Equipment	2-yellow	Default	Continuous
Architectural	A-DOOR	Doors	1-red	Default	Continuous
Architectural	A-DOOR-IDEN	Door number, hardware group, etc.	4-cyan	Default	Continuous
Architectural	A-FLOR-EVTR	Elevator cars and equipment	2-yellow	Default	Continuous
Architectural	A-FLOR-GRATE	Grating	2-yellow	Default	Continuous
Architectural	A-FLOR-IDEN-ROOM	Room numbers	7-white	Default	Continuous
Architectural	A-FLOR-IDEN-PRE-EPIC	Pre-EPIC Room numbers	7-white	Default	Continuous
Architectural	A-FLOR-IDEN-TEXT	Room names, targets, occupants, etc.	7-white	Default	Continuous
Architectural	A-FLOR-SHFT	Shafts	2-yellow	Default	Continuous
Architectural	A-FLOR-SIGN	Signage	1-red	Default	Continuous
Architectural	A-FLOR-STRS	Stair treads, escalators, ladders, level changes, ramps, pits, depressions	2-yellow	Default	Continuous
Architectural	A-ROOF	Roof	1-red	Default	Continuous
Architectural	A-WALL-EXTR	Exterior Building Wall	5-blue	Default	Continuous
Architectural	A-WALL-INTR	Interior Building Wall	3-green	Default	Continuous
Architectural	A-WNDW	Windows, curtain walls, glazed partitions	4-cyan	Default	Continuous
General	DEFPOINTS	Defpoints	7-white	Default	Continuous
Electrical	E-LITE	Lighting	3-green	Default	Continuous
Electrical	E-LITE-EXIT	Exit lighting	3-green	Default	Continuous
Electrical	E-POWR-WALL	Power wall outlets and receptacles	3-green	Default	Continuous
Electrical	E-SAFETY-CRDRDR	Card reader	3-green	Default	Continuous
Electrical	E-SAFETY-ICDB	Intercom/door buzzer system	3-green	Default	Continuous
General	G-ANNO-SYMB	Symbols	7-white	Default	Continuous
General	G-ANNO-TEXT	General Text	7-white	Default	Continuous
General	G-ANNO-TTLB	Border and Title Block	7-white	Default	Continuous
General	G-ANNO-TTLB-TEXT	Border and Title Block Text	7-white	Default	Continuous
General	G-LOGO	Title Block Logo	94,56,150	Default	Continuous
General	G-SCALE	Scale	7-white	Default	Continuous
General	G-VP	Viewport	7-white	Default	Continuous
Interior	I-EQPM-FIX	Fixed Equipment, except HVAC	6-magenta	Default	Continuous
Interior	I-EQPM-MOVE	Moveable equipment	6-magenta	Default	Continuous
Interior	I-FURN	Furniture	6-magenta	Default	Continuous
Interior	I-MILLWORK	Cabinetry / Casement	6-magenta	Default	Continuous
Landscaping	L-SITE	Site improvements	4-cyan	Default	Continuous
Mechanical	M-HVAC-EQPM	Mechanical equip. (chiller, boiler etc.)	6-magenta	Default	Continuous
Plumbing	P-FIXT	Plumbing fixtures, toilets, sinks	6-magenta	Default	Continuous
Plumbing	P-SAFETY-SHWSH	Emergency shower and eye wash	6-magenta	Default	Continuous
Structural	S-COLS	Columns	2-yellow	Default	Continuous
Structural	S-GRID	Column grid	2-yellow	Default	Center
Telecomm	T-JACK	Data/telephone jacks	3-green	Default	Continuous

BUILDING INFORMATION MODELING

Where so stipulated by Services Order, RFQ, or RFP, Building Information Modeling (BIM) shall be implemented throughout the project lifecycle. In these documents the A/E Team will find a list of intended BIM Uses requested by NYU Langone Health. The A/E Team is expected to capture these requirements, at minimum, in the project's BIM Execution Plan.

1. *BIM Execution Plan*

The A/E Team shall develop a BIM Execution Plan in the Schematic Design Phase and maintain and implement the BIM Execution Plan throughout the various phases of the project. The BIM Execution Plan shall include but not be limited to:

- *Plan Overview*
- *Project Goals/BIM Uses* - The A/E Team shall identify BIM Uses that aid in the development and delivery of a project's scope of work including but not limited to:
 - Existing Condition Modeling
 - Design Authoring
 - Design Review
 - Drawing Generation
 - Phase Planning
 - 3D Coordination
- *Organizational BIM Roles*
- *BIM Process Mapping*
- *Information Exchange*
- *Collaboration Procedure*
- *Quality Control*
- *Technical Needs*
- *Model Structure*
- *Project Deliverables* - The A/E Team shall provide a list of project-specific BIM deliverables organized by project phase. Appropriate Model Levels of Development shall be identified for each deliverable listed.

2. *BIM Uses*

The following list of BIM uses shall be used on NYU Langone Health RED+F projects. They are broken up into those provided as Basic Services for all projects designated to be delivered using BIM, and those uses that may be additionally requested in the Services Order, RFQ or RFP. BIM uses shall be assessed and recorded in the BIM Execution Plan to be provided by the A/E Team to NYU Langone RED+F for each project.

BASIC SERVICES	
BIM Use	Goal
Programming	<ul style="list-style-type: none"> Include NYU Langone space programming data and validate program meets requirements.
Existing Conditions Modeling	<ul style="list-style-type: none"> Create existing conditions models within project scope for areas to be surveyed or field verified prior to commencing design.
Design Authoring	<ul style="list-style-type: none"> All projects to use Autodesk Revit BIM authoring application.
Drawing Generation (Drawing Production)	<ul style="list-style-type: none"> Derive all drawings from Autodesk Revit BIM authoring application during all phases of a project.
Design Reviews	<ul style="list-style-type: none"> Visually review design solutions in 3d or virtually; validate end user design requirements; evaluate alternatives.
3D Coordination	<ul style="list-style-type: none"> Eliminate conflicts prior to construction, reduce RFI's, and eliminate field condition change orders.
Field and Management Tracking	<ul style="list-style-type: none"> NYU Langone Health to make available the use of BIM 360 during construction administration.

ADDITIONAL SERVICES	
BIM Use	Goal
Cost Estimation (Quantity Take-off)	<ul style="list-style-type: none"> Early master planning and design cost estimation based on gross sq. ft. rentable, lease, etc. using historical cost data. Quantify model objects, and track cost and cost changes during design and construction.
Phase Planning (4D Modeling)	<ul style="list-style-type: none"> Preliminary phasing studies, project phasing, master planning, linked to schedules for sequencing, visual studies. Project phasing during design and construction, for visualization, presentation, design consultant/construction schedules, and construction logistics.
Site Analysis	<ul style="list-style-type: none"> Site studies, building orientation, real estate acquisitions, master planning.
Engineering Analysis	<ul style="list-style-type: none"> Engineering analysis tools and processes to use BIM + BIM data for analysis. (Structural, Mechanical, etc.)

Energy Analysis	<ul style="list-style-type: none"> ▪ Specific engineering analysis on energy use. Validating BIM and design performance.
Lighting Analysis	<ul style="list-style-type: none"> ▪ Optimize lighting analysis design solutions. Indoor (artificial) vs outdoor (natural) light.
Sustainability / LEED Evaluation	<ul style="list-style-type: none"> ▪ Appropriately categorize and identify all sustainability criteria; NYU Langone Health to be able to distinguish building objects etc. impacting sustainability goals.
Code Validation	<ul style="list-style-type: none"> ▪ Code validation; design consultant to validate fire and life safety code compliance, egress, travel distances, etc.
Site Utilization Planning	<ul style="list-style-type: none"> ▪ Project phasing during construction, for visualization, presentation, construction logistics, site planning, and schedules.
Construction System Design (Virtual Mockup)	<ul style="list-style-type: none"> ▪ Construction system design, required planning for logistics / workflow (i.e. placing large equipment, MRI machines, etc.)
Digital Fabrication	<ul style="list-style-type: none"> ▪ Design to fabrication
3D Control and Planning (Digital Layout)	
Record Modeling	<ul style="list-style-type: none"> ▪ NYU Langone Health to require record model of as-built conditions to include data and documentation necessary in support of FM/OM. ▪ NYU Langone Health to use and maintain record model for FM/OM.
Building (Preventative) Maintenance Scheduling	<ul style="list-style-type: none"> ▪ Update and maintain BIM in alignment with Building Maintenance Scheduling.
Building Systems Analysis	<ul style="list-style-type: none"> ▪ NYU Langone Health to analyze and compare performance of building systems to design intent.
Asset Management	<ul style="list-style-type: none"> ▪ NYU Langone Health to link FM/OM asset data to BIM.
Space Management and Tracking	<ul style="list-style-type: none"> ▪ NYU Langone Health to integrate BIM space data and floor plans with IWMS Planon.
Disaster Planning	<ul style="list-style-type: none"> ▪ NYU Langone Health to leverage BIM in disaster planning and recovery.

SPACE PLANNING

RED+F has developed this subsection based on space planning layouts that we have found to be successful at NYU Langone Health. Our goal in providing this information is to streamline the design process by providing the Architect and Interior Designer pertinent information they can use during the programming and planning phases of a project. The information provided includes:

1. Floor Area Definitions
2. Planning Definitions
3. Formulas and Ratios
4. Space Types by Staff Title
5. Typical Room Sizes and Furniture Layouts

This information does not relieve the Architect or Interior Designer of designing a project that is code compliant and appropriate to the needs of the user. The Architect and Interior Designer may suggest other room and furniture layouts if they believe the proposed layouts support our mission, design principles, and the design intent of the project.

1. Floor Area Definitions

The Architect and Interior Designer shall provide floor area information to NYU Langone based on the following definitions:

- **Gross Square Feet (GSF)** - Floor area measured to the outside face of a building's exterior walls. GSF shall include the exterior wall thickness and all vertical penetrations (i.e. mechanical, electrical, plumbing, and elevator shafts, stairwells, etc.), as well as basements and garages.
- **Gross Departmental Square Feet (GDSF)** - The floor area for each department shall be measured from the outside face of a building's exterior walls, the centerline of shared walls and to the corridor side of corridor walls. Building and Floor Common Elements shall be apportioned based on the percentage of the floor occupied by each department. In cases where the department occupies an entire floor of a building the GSF shall be used.
- **Usable Square Feet (USF)** - Gross floor area less Building Common Elements. For multi-tenant/department floors, Floor Common Elements shall be apportioned based on the percentage of the floor occupied by each tenant/department. (per REBNY)
- **Net Square Feet (NSF)** - The area occupied by each identified program space measured to the centerline of interior partitions. Examples of such spaces include individual workspaces (i.e. workstations and offices), dedicated support spaces (i.e. conference rooms), shared support spaces (i.e. shared copier rooms, break rooms, etc.) and special mission-critical spaces (i.e. exam rooms, laboratories, etc.). Note: Building Common Elements, Floor Common Elements, and primary and secondary circulation are not included.

- **Building Common Elements** - The building core and common elements include portions of a building that *serve all tenants*. Such items, inclusive of their nominal 4” enclosing walls, include equipment/utility rooms (i.e. mechanical, electrical and telecom rooms serving the entire building), HVAC shafts, telecom / electrical distribution shafts, elevator shafts, public stairwells, etc. (per REBNY)
- **Floor Common Elements** - The floor common elements include portions of a floor that *serve all tenants of that floor*. Such items, not inclusive of their enclosing walls, include corridors, common toilets, shared supply rooms, etc. (per REBNY)

2. Planning Definitions

The Architect and Interior Designer shall provide planning information/calculations to NYU Langone based on the following definitions:

- **Max. Allowable Occupancy** - Maximum occupancy of a space as calculated per the Building Code(s).
 - Note: The A/E Team needs to calculate the maximum allowable occupancy within a space per the Building Code(s) based on several factors including but not limited to egress stair widths, exit door widths, plumbing fixture counts, etc.
- **Workplace Seating (WPS)** - Seating designated for use by a single employee. This can be located within an open area or in an enclosed room as described below. Total workplace seating represents the total number of employees in a particular department.
 - **Open Workplace Seating** - Seating designated for use by a single employee in an open area. This is a permanent seat such as a:
 - Workstation
 - Bench
 - Reception
 - **Enclosed Workplace Seating** - Seating designated for use by a single employee in an enclosed room such as a:
 - Private Office
- **Collaboration Seating** - Seating available for use by a group of employees and/or visitors. This can be located within an open area or in an enclosed room as described below:
 - **Open Collaboration Seating** - Seating available for use by a group of employees and/or visitors in an open area. Examples of such seating include:
 - Waiting Areas
 - Pantries
 - Open Collaboration areas
 - **Enclosed Collaboration Seating** - Seating available for use by a group of employees and/or visitors in an enclosed room. Examples of such seating include:
 - Quiet Rooms
 - Discussion Rooms
 - Conference Rooms
 - Training Rooms
 - Multi-Purpose Rooms

3. Formulas and Ratios

The following information is intended to assist the Architect and Interior Designer during the planning and programming phases. The Architect and Interior Designer must also factor in circulation and support spaces (i.e. copy rooms, filing rooms, storage closets, lactation rooms, etc.) into their design.

- **USF = GSF – (Building Common Elements)**
- **USF / WPS = USF ÷ Total # Anticipated WPS**
Note: On average Administrative spaces should result in a USF / WPS of 100-150 sf.
- **Ratio of Open WPS = # of Open WPS ÷ Total # of WPS**
Note: On average Administrative spaces should result in a Ratio of Open WPS of 75-85%.
- **Ratio of Workplace Seats to Collaboration Seats:**
Note: Administrative spaces have the following approximate ratios based on seating types for a department:
 - Workplace Seating : Collaboration Seating = 1 : 0.6 to 1 : 1
 - Encl. Workplace Seating : Open Workplace Seating = 1 : 2.8 to 1 : 5.4
 - Encl. Collaboration Seating : Open Collaboration Seating = 1 : 0.3 to 1 : 0.4
 - Workplace Seating : Enclosed Collaboration Seating = 1 : 0.4 to 1 : 0.6
 - Workplace Seating : Open Collaboration Seating = 1 : 0.2 to 1 : 0.5
 - Workplace Seating : Pantry Seating = 1 : 0.2 to 1 : 0.3
 - Open Workplace Seating : Lockers = 1 : 1 to 1 : 1.5
 - Workplace Seating : Waiting = 1 : 0.05 to 1 : 0.1

Legend:

- USF = Usable Square Feet
- GSF = Gross Square Feet
- WPS = Workplace Seats

4. *Space Types by Staff Title*

The following chart represents the square footage requirements for typical work spaces as they relate to staff titles:

STAFF TITLE / POSITION		SPACE REQUIREMENTS	
Academic / Clinical / Research	Admin / Hospital OPs	Type	Target Floor Area
Department Chair	SVP	Extra-Large Private Office	160 - 170 SF
Vice Chair	-	Large Private Office	120 - 130 SF
Director / Wet Lab Research Faculty	-	Medium Private Office	100 - 110 SF
Research Faculty	-	Private Office	85 - 95 SF
Faculty / MD	VP / Director	Small Private Office	80 - 85 SF
Fellows / Staff	Manager / Staff	Workstation	35 - 40 SF
Residents / Post Docs	Admin Staff / Consultant	Bench Seating	5 – 6 LF
Notes: 1. Target floor areas are approximate. 2. Spaces can be modified to fit within site conditions including the structural grid and building core.			

5. *Typical Room Sizes and Furniture Layouts*

The pages that follow show typical room sizes and furniture layouts for various space types. The space types included are:

- A. Reception Desk A (Non-Clinical)
- B. Reception Desk B (Clinical)
- C. Financial Counselor Desk (Clinical)
- D. Self-Check-in Equipment
- E. Exam Room A (Side-by-Side Config.)
- F. Exam Room B (Interlocking Config.)
- G. Bench Seating
- H. Workstation
- I. Workstation Configurations
- J. Small Private Office
- K. Medium Private Office
- L. Large Private Office
- M. Extra-Large Private Office
- N. Discussion Room
- O. Small Conference Room (8 person)
- P. Medium Conference Room (12 person)
- Q. Large Conference Room (24 person)
- R. Extra-Large Conference Room (34 person)
- S. Training Room
- T. Open Collaboration
- U. Enclosed Collaboration
- V. Multipurpose Room
- W. Lecture Hall (150 person)
- X. Small Pantry (25 person)
- Y. Medium Pantry (50 person)
- Z. Large Pantry (75 person)
- AA. Lactation Room
- BB. Wellness / Quiet Room
- CC. Digital Regulatory & Departmental Signage
- DD. Device Alignment
- EE. Kronos Timeclock Equipment

A. RECEPTION DESK A (NON-CLINICAL)

Size	
Area:	Varies
Interior Dimensions:	Varies

Furniture & Accessories	
F1	Feature Wall (Wood, Backlit Glass, etc.)
F2	Worksurface (29" H)
F3	Transaction Counter (42" H)
F4	Task Chair
F5	Box/Box/File Pedestal
F6	Overhead Storage
F7	Counter (34" H) w/ base cabinets
F8	Recycling (Paper only)

Equipment	
EQ1	Printer/Copier

Signage	
S1	Logo
S2	Donor Recognition
S3	Department Name
S4	Room Identification

Notes

1. Refer to other subsections of these Design Guidelines for further information.
2. Coordinate power/data infeed, receptacle/grommet quantities and locations with RED+F PM, MCIT, and NYULH Furniture Dealer.
3. IT requirements and equipment to be coordinated with MCIT.
4. All signage locations are for reference only and are to be determined at the site by RED+F's Signage / Wayfinding Group.

A. RECEPTION DESK A (NON-CLINICAL)																	
<p>A1 - ELEVATION</p>	<table border="1"> <thead> <tr> <th colspan="2" style="background-color: #4b4b8b; color: white;">Size</th> </tr> </thead> <tbody> <tr> <td>Area:</td> <td>Varies</td> </tr> <tr> <td>Interior Dimensions:</td> <td>Varies</td> </tr> <tr> <th colspan="2" style="background-color: #4b4b8b; color: white;">Furniture & Accessories</th> </tr> <tr> <td>F1</td> <td>Feature Wall (Wood, Backlit Glass, etc.)</td> </tr> <tr> <td>F2</td> <td>Worksurface (29" H)</td> </tr> <tr> <td>F3</td> <td>Transaction Counter (42" H)</td> </tr> <tr> <td>F4</td> <td>Stainless Steel Trim</td> </tr> </tbody> </table>	Size		Area:	Varies	Interior Dimensions:	Varies	Furniture & Accessories		F1	Feature Wall (Wood, Backlit Glass, etc.)	F2	Worksurface (29" H)	F3	Transaction Counter (42" H)	F4	Stainless Steel Trim
Size																	
Area:	Varies																
Interior Dimensions:	Varies																
Furniture & Accessories																	
F1	Feature Wall (Wood, Backlit Glass, etc.)																
F2	Worksurface (29" H)																
F3	Transaction Counter (42" H)																
F4	Stainless Steel Trim																
<p>A2 - ELEVATION</p>	<table border="1"> <thead> <tr> <th colspan="2" style="background-color: #4b4b8b; color: white;">Equipment</th> </tr> </thead> <tbody> <tr> <td> </td> <td> </td> </tr> </tbody> </table>	Equipment															
Equipment																	
<p>A3 - SECTION</p>	<table border="1"> <thead> <tr> <th colspan="2" style="background-color: #4b4b8b; color: white;">Signage</th> </tr> </thead> <tbody> <tr> <td>S1</td> <td>Logo</td> </tr> <tr> <td>S2</td> <td>Donor Recognition</td> </tr> <tr> <td>S3</td> <td>Department Name</td> </tr> </tbody> </table>	Signage		S1	Logo	S2	Donor Recognition	S3	Department Name								
Signage																	
S1	Logo																
S2	Donor Recognition																
S3	Department Name																
Notes																	
<ol style="list-style-type: none"> 1. Refer to other subsections of these Design Guidelines for further information. 2. Coordinate power/data infeed, receptacle/grommet quantities and locations with RED+F PM, MCIT, and NYULH Furniture Dealer. 3. IT requirements and equipment to be coordinated with MCIT. 4. All signage locations are for reference only and are to be determined at the site by RED+F's Signage / Wayfinding Group. 5. Coordinate knee clearances with equipment / devices below worksurface. 																	

B. RECEPTION DESK B (CLINICAL)	
	Size
	Area: Varies
	Interior Dimensions: Varies
	Furniture & Accessories
	<p>F1 Feature Wall (Wood, Backlit Glass, etc.)</p> <p>F2 Worksurface (29" H)</p> <p>F3 Transaction Counter (42" H)</p> <p>F4 Task Chair</p> <p>F5 Guest Chair</p> <p>F6 Privacy Screen</p> <p>F7 Lateral File w/ counter above</p> <p>F8 Box/Box/File Pedestal</p> <p>F9 Storage, Cabinets or Shelving (where possible)</p> <p>F10 Recycling (Confidential Paper only)</p>
	Equipment
	<p>EQ1 Printer/Copier</p> <p>EQ2 EPIC Printer</p>
	Signage
	<p>S1 Logo</p> <p>S2 Donor Recognition</p> <p>S3 Department Name</p> <p>S4 Room Identification</p>
Notes	
<p>1. Refer to other subsections of these Design Guidelines for further information.</p> <p>2. Refer to the <i>NYU Langone Health – Hardware Standards</i> and coordinate electrical/IT requirements with MCIT.</p> <p>3. Coordinate power/data infeed, receptacle/grommet quantities and locations with RED+F PM, MCIT, and NYULH Furniture Dealer.</p> <p>4. All signage locations are for reference only and are to be determined at the site by RED+F's Signage / Wayfinding Group.</p>	

B. RECEPTION DESK B (CLINICAL)	
<p>B1 - ELEVATION</p> <p>B2 - ELEVATION</p> <p>0 1 2 4</p>	<p>Size</p> <p>Area: Varies Interior Dimensions: Varies</p> <p>Furniture & Accessories</p> <p>F1 Feature Wall (Wood, Backlit Glass, etc.) F2 Worksurface (29" H) F3 Transaction Counter (42" H) F4 Base Cabinets F5 Cabinets or Shelving (where possible) F6 Stainless Steel Trim F7 Printer Stand w/ Storage (Built-in or Freestanding)</p>
<p>B3 - SECTION</p> <p>0 1 2 4</p>	<p>Equipment</p> <p>EQ1 Intake Equipment EQ2 EPIC Printer</p> <p>Signage</p> <p>S1 Logo S2 Donor Recognition S3 Department Name</p>
<p>Notes</p> <ol style="list-style-type: none"> 1. Refer to other subsections of these Design Guidelines for further information. 2. Refer to the <i>NYU Langone Health – Hardware Standards</i> and coordinate electrical/IT requirements with MCIT. 3. Coordinate power/data infeed, receptacle/grommet quantities and locations with RED+F PM, MCIT, and NYULH Furniture Dealer. 4. All signage locations are for reference only and are to be determined at the site by RED+F's Signage / Wayfinding Group. 5. Coordinate knee clearances with equipment / devices below worksurface. 6. If EPIC printer is not full height as shown, provide storage below. 	

C. FINANCIAL COUNSELOR DESK (CLINICAL)	
	Size
	Area: Varies Interior Dimensions: Varies
	Furniture & Accessories
	F1 Worksurface (29" H) F2 Task Chair F3 Guest Chair F4 Privacy Screen F5 Lateral File w/ counter above F6 Box/Box/File Pedestal F7 Recycling (Confidential Paper only)
	Equipment
	EQ1 EPIC Printer (below counter)
	Signage
	S1 Room Identification
Notes	
<ol style="list-style-type: none"> 1. Refer to other subsections of these Design Guidelines for further information. 2. Refer to the <i>NYU Langone Health – Hardware Standards</i> and coordinate electrical/IT requirements with MCIT. 3. Coordinate power/data infeed, receptacle/grommet quantities and locations with RED+F PM, MCIT, and NYULH Furniture Dealer. 4. All signage locations are for reference only and are to be determined at the site by RED+F's Signage / Wayfinding Group. 5. Coordinate knee clearances with equipment / devices below worksurface. 	

D. SELF-CHECK-IN EQUIPMENT	
	Size
	Area: Varies Interior Dimensions: As Shown
	Furniture & Accessories
	F1 Counter (34" H) F2 Grommet F3 Removeable Panel to conceal wire management F4 Millwork Apron
	Equipment
	EQ1 Self-Check-in Equipment EQ2 Power/Data (1-outlet of each type is required per kiosk assembly directly below counter)
	Signage
Notes	
<ol style="list-style-type: none"> 1. Check-in equipment shall be located between the department entry and the reception desk. Proximity to the reception desk is preferred. 2. Refer to other subsections of these Design Guidelines for further information. 3. Refer to the <i>NYU Langone Health – Hardware Standards</i> and coordinate IT requirements with MCIT. 	

E. EXAM ROOM A (SIDE-BY-SIDE CONFIGURATION)	
	Size
	Area: Varies
	Interior Dimensions: As Shown
	Furniture & Accessories
	F1 Clinician’s Stool F2 Guest Chair F3 Millwork / Casework F4 Paper Towel Dispenser F5 Soap Dispenser F6 Purell Dispenser F7 Tan Step Recep. (trash only) F8 Sharps Container F9 2 x Coat Hooks F10 Privacy Curtain (if required)
Plumbing Fixtures	
P1 Faucet P2 Sink	
Equipment	
EQ1 Exam Table / Chair EQ2 Computer Station (Wall Mounted / WOW) EQ3 Diagnostic Equipment EQ4 Scale EQ5 Stadiometer	
Signage	
S1 Room Identification	
Notes	
1. Refer to other subsections of these Design Guidelines for further information. 2. Refer to the <i>NYU Langone Health – Hardware Standards</i> and coordinate IT requirements with MCIT. 3. Coordinate medical equipment with Clinical Engineering. 4. Mount sharps container with opening at highest allowable ADA-compliant height. 5. If required, coordinate privacy curtain with RCP. 6. All signage locations are for reference only and are to be determined at the site by RED+F’s Signage / Wayfinding Group.	

F. EXAM ROOM B (INTERLOCKING CONFIGURATION)

Size	
Area:	Varies
Interior Dimensions:	As Shown

Furniture & Accessories	
F1	Clinician's Stool
F2	Guest Chair
F3	Millwork / Casework
F4	Paper Towel Dispenser
F5	Soap Dispenser
F6	Purell Dispenser
F7	Tan Step Recep. (trash only)
F8	Sharps Container
F9	2 x Coat Hooks
F10	Privacy Curtain (if required)

Plumbing Fixtures	
P1	Faucet
P2	Sink

Equipment	
EQ1	Exam Table / Chair
EQ2	Computer Station (Wall Mounted / WOW)
EQ3	Diagnostic Equipment
EQ4	Scale
EQ5	Stadiometer

Signage	
S1	Room Identification

Notes

1. Refer to other subsections of these Design Guidelines for further information.
2. Refer to the *NYU Langone Health – Hardware Standards* and coordinate IT requirements with MCIT.
3. Coordinate medical equipment with Clinical Engineering..
4. Mount sharps container with opening at highest allowable ADA-compliant height.
5. If required, coordinate privacy curtain with RCP.
6. All signage locations are for reference only and are to be determined at the site by RED+F's Signage / Wayfinding Group.

G. BENCH SEATING	
	Size
	Area: Varies
	Interior Dimensions: 5 - 6 LF
	Furniture & Accessories
	F1 Worksurface (29" H)
	F2 Personal Storage (optional)
	F3 Desktop Privacy Screen
	F4 Task Chair
	F5 Task Light (optional)
	Equipment
	Signage
	S1 Desk Identification
Notes	
<ol style="list-style-type: none"> 1. Refer to other subsections of these Design Guidelines for further information. 2. Coordinate power/data infeed, receptacle/grommet quantities and locations with RED+F PM, MCIT, and NYULH Furniture Dealer. 3. IT requirements and equipment to be coordinated with MCIT. 4. All signage locations are for reference only and are to be determined at the site by RED+F's Signage / Wayfinding Group. 5. Coordinate knee clearances with equipment / devices below worksurface. 	

H. WORKSTATION	
	Size
	Target Floor Area: 35 - 40 sf Approx. Dimensions: 6'-0" X 6'-0"
	Furniture & Accessories
	F1 Worksurface (29" H) / Sit-to-Stand F2 Wardrobe (if lockers are not provided elsewhere) F3 Worksurface (29" H) w/ storage below, as req'd F4 Grommet F5 Tackable Surface F6 Task Chair F7 Task Light (optional) F8 Monitor Arm (optional)
	Equipment
	Signage
	S1 Desk Identification
Notes	
1. Refer to other subsections of these Design Guidelines for further information. 2. Coordinate power/data infeed, receptacle/grommet quantities and locations with RED+F PM, MCIT, and NYULH Furniture Dealer. 3. IT requirements and equipment to be coordinated with MCIT. 4. All signage locations are for reference only and are to be determined at the site by RED+F's Signage / Wayfinding Group. 5. Coordinate knee clearances with equipment / devices below worksurface.	

I. WORKSTATION CONFIGURATIONS									
<p style="text-align: center;">CIRCULATION</p> <p style="text-align: center;">OPTION A</p> <p style="text-align: center;">OPTION B</p> <p style="text-align: center;">OPTION C</p> <p style="text-align: center;">OPTION D</p>	<table border="1" style="width: 100%; border-collapse: collapse;"> <tr> <th style="background-color: #4b4b8b; color: white;">Size</th> </tr> <tr> <td style="height: 100px;"> </td> </tr> <tr> <th style="background-color: #4b4b8b; color: white;">Furniture & Accessories</th> </tr> <tr> <td style="height: 200px;"> </td> </tr> <tr> <th style="background-color: #4b4b8b; color: white;">Equipment</th> </tr> <tr> <td style="height: 100px;"> </td> </tr> <tr> <th style="background-color: #4b4b8b; color: white;">Signage</th> </tr> <tr> <td style="height: 100px;"> </td> </tr> </table>	Size		Furniture & Accessories		Equipment		Signage	
Size									
Furniture & Accessories									
Equipment									
Signage									
Notes									

J. SMALL PRIVATE OFFICE	
	Size
	Target Floor Area: 80 - 85 sf Approx. Dimensions: 8'-0" X 10'-0"
	Furniture & Accessories
	F1 Worksurface (29" H) F2 Sit-to-Stand F3 Wardrobe F4 Vertical Storage F5 Grommet F6 Tackable Surface F7 Task Chair F8 Guest Chair F9 Task Light (optional) F10 Monitor Arm (optional) F11 Coat Hook (optional)
	Equipment
	Signage
	S1 Room Identification
Notes	
1. Refer to other subsections of these Design Guidelines for further information. 2. Coordinate power/data infeed, receptacle/grommet quantities and locations with RED+F PM, MCIT, and NYULH Furniture Dealer. 3. IT requirements and equipment to be coordinated with MCIT. 4. For ADA compliant offices, the work surface can either be placed on casters or turned 90 degrees. 5. All signage locations are for reference only and are to be determined at the site by RED+F's Signage / Wayfinding Group. 6. Coordinate knee clearances with equipment / devices below worksurface.	

K. MEDIUM PRIVATE OFFICE	
	Size
	Target Floor Area: 100 - 110 sf Approx. Dimensions: 10'-0" X 10'-0"
	Furniture & Accessories
	F1 Worksurface (29" H) F2 Sit-to-Stand F3 Wardrobe F4 Vertical storage F5 Grommet F6 Tackable Surface F7 Task Chair F8 Guest Chair F9 Task Light (optional) F10 Monitor Arm (optional) F11 Coat Hook (optional)
	Equipment
	Signage
	S1 Room Identification
Notes	
1. Refer to other subsections of these Design Guidelines for further information. 2. Coordinate power/data infeed, receptacle/grommet quantities and locations with RED+F PM, MCIT, and NYULH Furniture Dealer. 3. IT requirements and equipment to be coordinated with MCIT. 4. For ADA compliant offices, the work surface can either be placed on casters or turned 90 degrees. 5. All signage locations are for reference only and are to be determined at the site by RED+F's Signage / Wayfinding Group. 6. Coordinate knee clearances with equipment / devices below worksurface.	

L. LARGE PRIVATE OFFICE	
	Size
	Target Floor Area: 120 - 130 sf Approx. Dimensions: 12'-6" X 10'-0"
	Furniture & Accessories
	F1 Worksurface (29" H) F2 Sit-to-Stand F3 Wardrobe F4 Vertical storage F5 Grommet F6 Tackable Surface F7 Task Chair F8 Guest Chair F9 Task Light (optional) F10 Monitor Arm (optional) F11 Coat Hook (optional)
	Equipment
	S1 Room Identification
	Signage
	S1 Room Identification
Notes	
1. Refer to other subsections of these Design Guidelines for further information. 2. Coordinate power/data infeed, receptacle/grommet quantities and locations with RED+F PM, MCIT, and NYULH Furniture Dealer. 3. IT requirements and equipment to be coordinated with MCIT. 4. For ADA compliant offices, the work surface can either be placed on casters or turned 90 degrees. 5. All signage locations are for reference only and are to be determined at the site by RED+F's Signage / Wayfinding Group. 6. Coordinate knee clearances with equipment / devices below worksurface.	

M. EXTRA-LARGE PRIVATE OFFICE	
	Size
	Target Floor Area: 160 - 170 sf Approx. Dimensions: 10'-0" X 16'-0"
	Furniture & Accessories
	F1 Worksurface (29" H) F2 Sit-to-Stand F3 Wardrobe F4 Vertical storage F5 Grommet F6 Tackable Surface F7 Task Chair F8 Guest Chair F9 Meeting Table F10 Task Light (optional) F11 Monitor Arm (optional) F12 Coat Hook (optional)
	Equipment
	EQ1 Digital Screen w/ AV
	Signage
	S1 Room Identification
Notes	
1. Refer to other subsections of these Design Guidelines for further information. 2. Coordinate power/data infeed, receptacle/grommet quantities and locations with RED+F PM, MCIT, and NYULH Furniture Dealer. 3. AV/IT requirements and equipment to be coordinated with MCIT. 4. Surface mounted equipment shall not protrude more than 4" from face of wall. 5. For ADA compliant offices, the work surface can either be placed on casters or turned 90 degrees. 6. All signage locations are for reference only and are to be determined at the site by RED+F's Signage / Wayfinding Group. 7. Coordinate knee clearances with equipment / devices below worksurface.	

N. DISCUSSION ROOM	
	Size
	Area: 150 sf Interior Dimensions: 12'-0" X 12'-6"
	Furniture & Accessories
	F1 Meeting Table w/ Integrated Technology F2 Conference Chair
	Equipment
	EQ1 Digital Screen w/ AV EQ2 Smart Board / Whiteboard
	Signage
	S1 Room Identification
Notes	
<ol style="list-style-type: none"> 1. Refer to other subsections of these Design Guidelines for further information. 2. Coordinate power/data infeed, receptacle/grommet quantities and locations with RED+F PM, MCIT, and NYULH Furniture Dealer. 3. AV/IT requirements and equipment to be coordinated with MCIT. 4. Surface mounted equipment shall not protrude more than 4" from face of wall. 5. All signage locations are for reference only and are to be determined at the site by RED+F's Signage / Wayfinding Group. 	

O. SMALL CONFERENCE ROOM (8 PERSON)	
	Size
	Area: 270 sf Interior Dimensions: 13'-6" X 20'-0"
	Furniture & Accessories
	F1 Conf. Table w/ Integrated Technology F2 Conference Chair F3 Credenza
	Equipment
	EQ1 Digital Screen w/ AV EQ2 Smartboard / Whiteboard EQ3 Clock (above EQ2)
	Signage
	S1 Room Identification
Notes	
<ol style="list-style-type: none"> 1. Refer to other subsections of these Design Guidelines for further information. 2. Floor stub-ups to be noted as "VIF". Final location to be identified in field by NYULH Furniture Dealer. 3. Coordinate power/data infeed, receptacle/grommet quantities and locations with RED+F PM, MCIT, and NYULH Furniture Dealer. 4. AV/IT requirements and equipment to be coordinated with MCIT. 5. Surface mounted equipment shall not protrude more than 4" from face of wall. 6. Locate full ceiling tile centered above conference room table. Do not locate a spline on center with the table. 7. All signage locations are for reference only and are to be determined at the site by RED+F's Signage / Wayfinding Group. 8. Credenza countertop shall extend to the back wall. 	

P. MEDIUM CONFERENCE ROOM (12 PERSON)

Size	
Area:	324 sf
Interior Dimensions:	13'-6" X 24'-0"

Furniture & Accessories	
F1	Conf. Table w/ Integrated Technology
F2	Conference Chair
F3	Credenza
F4	Trash / Recycling (built-in)

Equipment	
EQ1	Digital Screen w/ AV
EQ2	Smartboard / Whiteboard
EQ3	Clock (above EQ2)

Signage	
S1	Room Identification
S2	Trash/Recycling Decals

Notes

1. Refer to other subsections of these Design Guidelines for further information.
2. Floor stub-ups to be noted as "VIF". Final location to be identified in field by NYULH Furniture Dealer.
3. Coordinate power/data infeed, receptacle/grommet quantities and locations with RED+F PM, MCIT, and NYULH Furniture Dealer.
4. AV/IT requirements and equipment to be coordinated with MCIT.
5. Surface mounted equipment shall not protrude more than 4" from face of wall.
6. Locate full ceiling tile centered above conference room table. Do not locate a spline on center with the table.
7. All signage locations are for reference only and are to be determined at the site by RED+F's Signage / Wayfinding Group.
8. Credenza countertop shall extend to the back wall.

Q. LARGE CONFERENCE ROOM (24 PERSON)

Size	
Area:	462 sf
Interior Dimensions:	16'-6" X 28'-0"

Furniture & Accessories	
F1	Conf. Table w/ Integrated Technology
F2	Conference Chair
F3	Stacking Chair
F4	Credenza
F5	Trash / Recycling (built-in)

Equipment	
EQ1	Digital Screen w/ AV
EQ2	Smartboard / Whiteboard
EQ3	Clock (above EQ2)

Signage	
S1	Room Identification
S2	Trash/Recycling Decals

Notes

1. Refer to other subsections of these Design Guidelines for further information.
2. Floor stub-ups to be noted as "VIF". Final location to be identified in field by NYULH Furniture Dealer.
3. Coordinate power/data infeed, receptacle/grommet quantities and locations with RED+F PM, MCIT, and NYULH Furniture Dealer.
4. AV/IT requirements and equipment to be coordinated with MCIT.
5. Surface mounted equipment shall not protrude more than 4" from face of wall.
6. Locate full ceiling tile centered above conference room table. Do not locate a spline on center with the table.
7. All signage locations are for reference only and are to be determined at the site by RED+F's Signage / Wayfinding Group.
8. Credenza countertop shall extend to the back wall.

R. EXTRA-LARGE CONFERENCE ROOM (34 PERSON)															
	Size														
	Area: 770 sf														
	Interior Dimensions: 22'-0" X 35'-0"														
	Furniture & Accessories														
	<table border="0"> <tr> <td style="padding-right: 10px;">F1</td> <td>Conf. Table w/ Integrated Technology</td> </tr> <tr> <td>F2</td> <td>Conference Chair</td> </tr> <tr> <td>F3</td> <td>Stacking Chair</td> </tr> <tr> <td>F4</td> <td>Bench</td> </tr> <tr> <td>F5</td> <td>Credenza</td> </tr> <tr> <td>F6</td> <td>Lectern</td> </tr> <tr> <td>F7</td> <td>Trash / Recycling (built-in)</td> </tr> </table>	F1	Conf. Table w/ Integrated Technology	F2	Conference Chair	F3	Stacking Chair	F4	Bench	F5	Credenza	F6	Lectern	F7	Trash / Recycling (built-in)
F1	Conf. Table w/ Integrated Technology														
F2	Conference Chair														
F3	Stacking Chair														
F4	Bench														
F5	Credenza														
F6	Lectern														
F7	Trash / Recycling (built-in)														
	Equipment														
	<table border="0"> <tr> <td style="padding-right: 10px;">EQ1</td> <td>Digital Screen w/ AV</td> </tr> <tr> <td>EQ2</td> <td>Smartboard / Whiteboard</td> </tr> <tr> <td>EQ3</td> <td>Clock (above EQ2)</td> </tr> </table>	EQ1	Digital Screen w/ AV	EQ2	Smartboard / Whiteboard	EQ3	Clock (above EQ2)								
EQ1	Digital Screen w/ AV														
EQ2	Smartboard / Whiteboard														
EQ3	Clock (above EQ2)														
	Signage														
	<table border="0"> <tr> <td style="padding-right: 10px;">S1</td> <td>Room Identification</td> </tr> <tr> <td>S2</td> <td>Trash/Recycling Decals</td> </tr> </table>	S1	Room Identification	S2	Trash/Recycling Decals										
S1	Room Identification														
S2	Trash/Recycling Decals														
Notes															
<ol style="list-style-type: none"> 1. Refer to other subsections of these Design Guidelines for further information. 2. Floor stub-ups to be noted as "VIF". Final location to be identified in field by NYULH Furniture Dealer. 3. Coordinate power/data infeed, receptacle/grommet quantities and locations with RED+F PM, MCIT, and NYULH Furniture Dealer. 4. AV/IT requirements and equipment to be coordinated with MCIT. 5. Surface mounted equipment shall not protrude more than 4" from face of wall. 6. Locate full ceiling tile centered above conference room table. Do not locate a spline on center with the table. 7. All signage locations are for reference only and are to be determined at the site by RED+F's Signage / Wayfinding Group. 8. Credenza countertop shall extend to the back wall. 															

S. TRAINING ROOM	
<p>The diagram shows a rectangular room with overall dimensions of 21'-0" in width and 33'-0" in depth. The room is divided into several rows of furniture. At the top, there is a clock (EQ2) mounted on the wall. Below it are four rows of training tables (F2) with chairs (F3) tucked under them. The spacing between these rows is 3'-6". At the bottom of the room, there is a presenter's table (F1) and a digital screen (EQ1). A trash/recycling area (F4) is located outside the room. A door (S1) is on the right wall. A scale bar at the bottom right indicates 0, 1, 2, and 4 feet.</p>	Size
	Area: 693 sf
	Interior Dimensions: 21'-0" X 33'-0"
	Furniture & Accessories
	F1 Training Table (Presenter)
	F2 Training Table (Attendee)
	F3 Stacking / Nesting Chair
	F4 Trash / Recycling (outside)
	Equipment
	EQ1 Digital Screen w/ AV
	EQ2 Clock
	Signage
	S1 Room Identification
Notes	
1. Refer to other subsections of these Design Guidelines for further information.	
2. Coordinate power/data infeed, receptacle/grommet quantities and locations with RED+F PM, MCIT, and NYULH Furniture Dealer.	
3. AV/IT requirements and equipment to be coordinated with MCIT.	
4. Surface mounted equipment shall not protrude more than 4" from face of wall.	
5. All signage locations are for reference only and are to be determined at the site by RED+F's Signage / Wayfinding Group.	

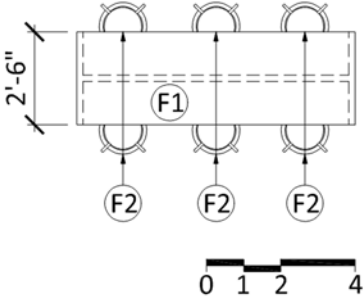
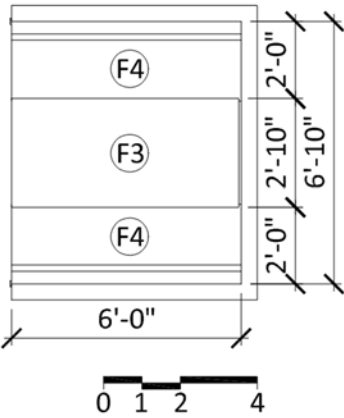
T. OPEN COLLABORATION	
<p>HIGHTOP SEATING</p> 	Size
	Area: Varies Interior Dimensions: Varies
	Furniture & Accessories
	F1 Table (42" H) F2 Stool F3 Tabletop (29" H) F4 Banquet Seating
<p>BOOTH SEATING</p> 	Equipment
	Signage
	S1 Area Identification (optional)
Notes	
<ol style="list-style-type: none"> 1. Refer to other subsections of these Design Guidelines for further information. 2. All signage locations are for reference only and are to be determined at the site by RED+F's Signage / Wayfinding Group. 	

U. ENCLOSED COLLABORATION	
<p>PHONE BOOTH Dimensions: 6'-0" x 7'-0" Furniture: F1, F3 Signage: S1</p> <p>TRAIN CAR Dimensions: 6'-0" x 8'-0" Furniture: F2, F3 Equipment: EQ1 Signage: S1</p> <p>HUDDLE ROOM Dimensions: 10'-0" x 10'-6" Furniture: F1, F2, F3, F4 Equipment: EQ1 Signage: S1</p>	Size Area: Varies Interior Dimensions: Varies
	Furniture & Accessories F1 Lounge Chair F2 Sofa F3 Occasional Table F4 Coffee Table
	Equipment EQ1 Digital Screen w/ AV
	Signage S1 Room Identification
Notes 1. Refer to other subsections of these Design Guidelines for further information. 2. All signage locations are for reference only and are to be determined at the site by RED+F's Signage / Wayfinding Group.	

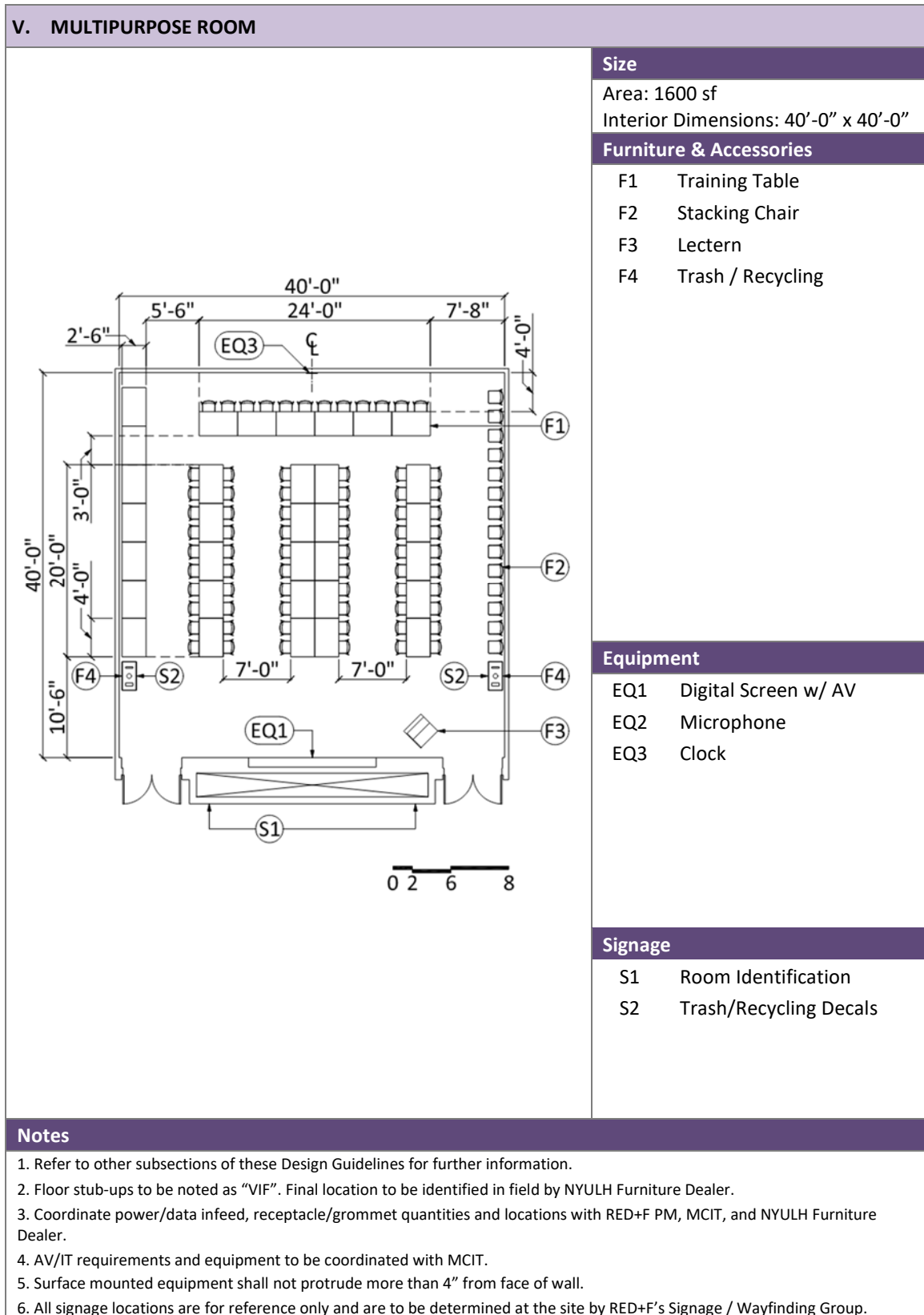

W. LECTURE HALL (150 PERSON)	
	Size
	Area: 1800 sf Interior Dimensions: 40'-0" X 45'-0"
	Furniture & Accessories
	F1 Lectern F2 Auditorium Seating F3 Removable Auditorium Seating (ADA-compliant) F4 Trash / Recycling (outside)
	Equipment
	EQ1 Digital Screen w/ AV EQ2 Microphone EQ3 Clock
	Signage
	S1 Room Identification
Notes	
<ol style="list-style-type: none"> 1. Refer to other subsections of these Design Guidelines for further information. 2. Floor stub-ups to be noted as "VIF". Final location to be identified in field by NYULH Furniture Dealer. 3. Coordinate power/data infeed, receptacle/grommet quantities and locations with RED+F PM, MCIT, and NYULH Furniture Dealer. 4. AV/IT requirements and equipment to be coordinated with MCIT. 5. Surface mounted equipment shall not protrude more than 4" from face of wall. 6. All signage locations are for reference only and are to be determined at the site by RED+F's Signage / Wayfinding Group. 	

X. SMALL PANTRY (25 PERSON)

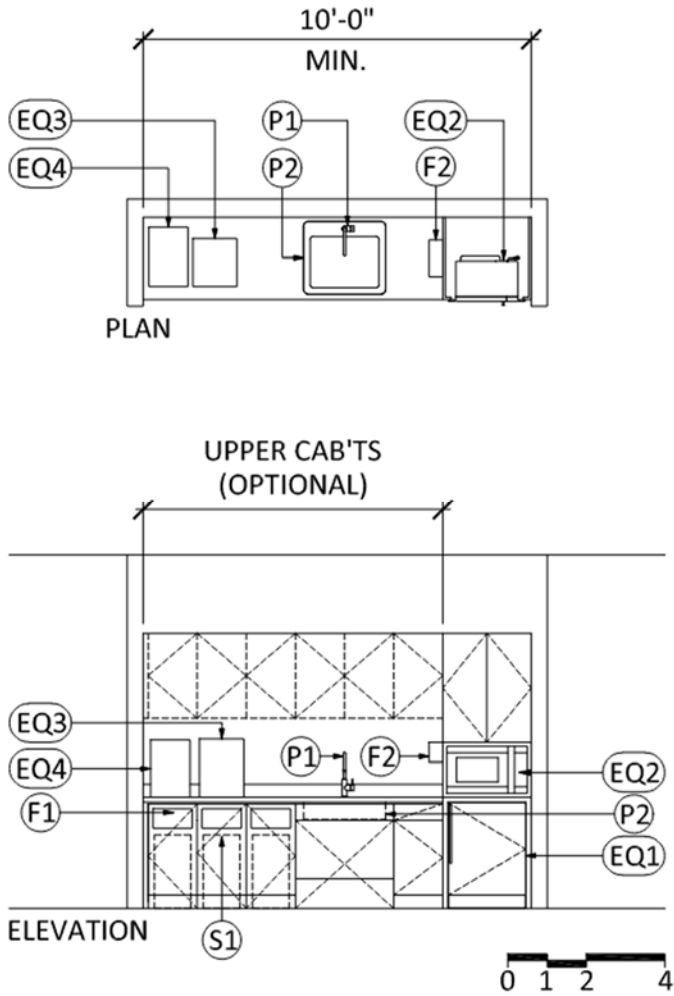

Size

Area: Varies
Interior Dimensions: 10 LF (min.)

Furniture & Accessories

- F1 Trash / Recycling (built-in)
- F2 Paper Towel Dispenser (see Building Accessories)

Plumbing Fixtures

- P1 Faucet
- P2 Sink

Equipment

- EQ1 Undercounter Refrigerator/Freezer
- EQ2 Microwave
- EQ3 Countertop Water Disp.
- EQ4 Coffee Maker

Signage

- S1 Trash/Recycling Decals

Notes

1. Refer to other subsections of these Design Guidelines for further information.
2. Coordinate millwork details with equipment to ensure proper structural support is factored in.
3. All signage locations are for reference only and are to be determined at the site by RED+F's Signage / Wayfinding Group.

Y. MEDIUM PANTRY (50 PERSON)	
	Size
	Area: Varies Interior Dimensions: 13 LF (min.)
	Furniture & Accessories
	F1 Trash / Recycling (built-in) F2 Paper Towel Dispenser (see Building Accessories)
	Plumbing Fixtures
	P1 Faucet P2 Sink
	Equipment
	EQ1 Refrigerator/Freezer EQ2 Microwave EQ3 Countertop Water Disp. EQ4 Coffee Maker
	Signage
	S1 Trash/Recycling Decals
Notes	
1. Refer to other subsections of these Design Guidelines for further information. 2. Coordinate millwork details with equipment to ensure proper structural support is factored in. 3. All signage locations are for reference only and are to be determined at the site by RED+F's Signage / Wayfinding Group.	

Z. LARGE PANTRY (75 PERSON)

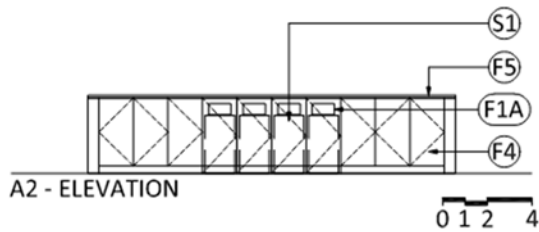
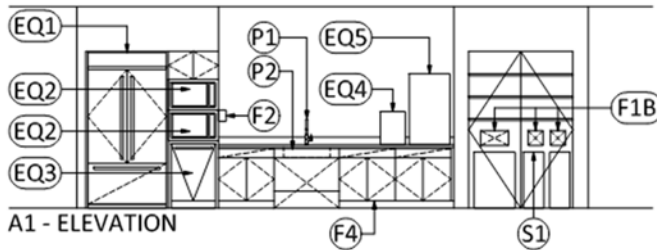
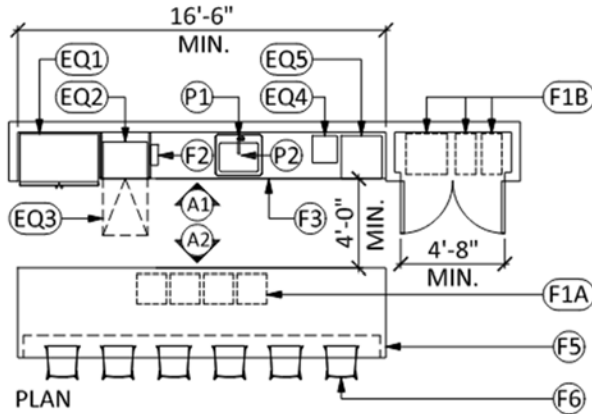

Size

Area: Varies
Interior Dimensions: 16'-6" (min.)

Furniture & Accessories

- F1A Trash / Recycling (preferred built into island)
- F1B Trash / Recycling (Alternate location w/in pantry closet)
- F2 Paper Towel Dispenser (see Building Accessories)
- F3 Counter (34" H)
- F4 Base Cabinets
- F5 Island (42" H)
- F6 Stool

Plumbing Fixtures

- P1 Faucet
- P2 Sink

Equipment

- EQ1 Refrigerator/Freezer
- EQ2 Microwave
- EQ3 Dishwasher (optional)
- EQ4 Water Cooler
- EQ5 Coffee Maker

Signage

- S1 Trash/Recycling Decals

Notes

1. Refer to other subsections of these Design Guidelines for further information.
2. Coordinate millwork details with equipment to ensure proper structural support is factored in.
3. All signage locations are for reference only and are to be determined at the site by RED+F's Signage / Wayfinding Group.

AA. LACTATION ROOM

Size	
Area:	80 sf
Interior Dimensions:	10'-0" X 8'-0"

Furniture & Accessories	
F1	Lounge Chair
F2	Occasional Table
F3	2x Coat Hooks
F4	Trash only (built-in)
F5	Art
F6	Paper Towel Dispenser (see Building Accessories)
F7	Soap Dispenser
F8	Frameless Mirror
F9	Lockers (see Furniture)
F10	Soffit

Plumbing Fixtures	
P1	Faucet
P2	Sink

Equipment	
EQ1	Undercounter Refrigerator

Signage	
S1	Room Identification
S2	Trash/Recycling Decals

Notes

1. Refer to other subsections of these Design Guidelines for further information.
2. Coordinate millwork details with equipment to ensure proper structural support is factored in.
3. All signage locations are for reference only and are to be determined at the site by RED+F's Signage / Wayfinding Group.
4. ADA mirrors shall be specified with the bottom of the reflective surface at 40" AFF, not the mirror frame.
5. Provide dimmable light and switch.
6. Provide (1) convenience duplex power outlet on either side of the chair at 18" AFF.
7. Provide card reader access, passage lockset and thumbturn bolt with occupancy indicator.

BB. WELLNESS/QUIET ROOM	
	Size
	Area: 80 sf Interior Dimensions: 10'-0" X 8'-0"
	Furniture & Accessories
	F1 Lounge Chair F2 Occasional Table F3 2x Coat Hooks F4 Art
	Equipment
	Signage
	S1 Room Identification
Notes	
<ol style="list-style-type: none"> 1. Refer to other subsections of these Design Guidelines for further information. 2. All signage locations are for reference only and are to be determined at the site by RED+F's Signage / Wayfinding Group. 3. Provide dimmable light and switch. 4. Provide (1) convenience duplex power outlet on either side of the chair at 18" AFF. 5. Provide passage lockset and thumbturn bolt with occupancy indicator. 	

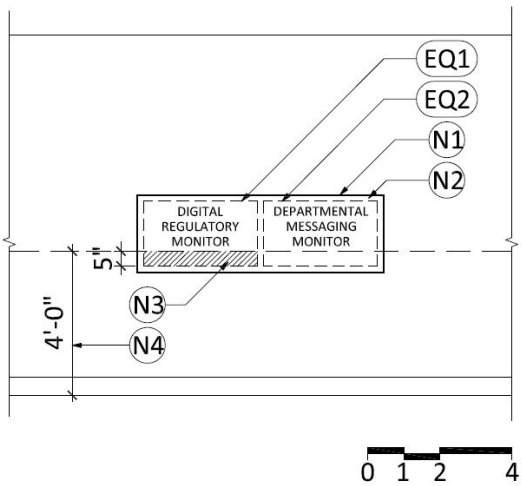
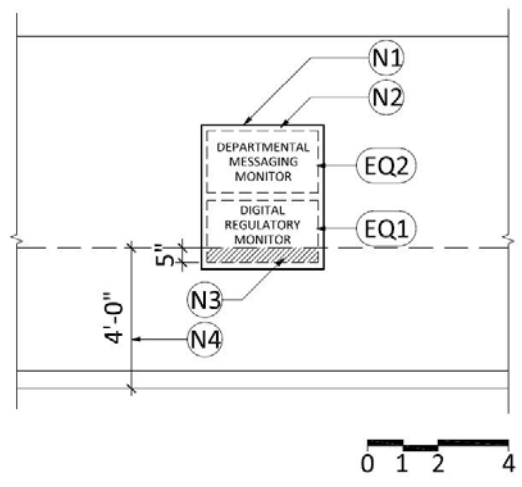
CC. DIGITAL REGULATORY & DEPARTMENTAL SIGNAGE																											
 <p style="text-align: center;">** Preferred Configuration **</p>	<table border="1"> <thead> <tr> <th colspan="2" style="background-color: #4b4b8b; color: white;">Size</th> </tr> </thead> <tbody> <tr> <td>Area:</td> <td>Varies</td> </tr> <tr> <td>Interior Dimensions:</td> <td>Varies</td> </tr> <tr> <th colspan="2" style="background-color: #4b4b8b; color: white;">Drawing Notes</th> </tr> <tr> <td>N1</td> <td>¼" thick stainless steel trim full depth of recess. Trim to protrude ½" from face of wall. Black metal backpan within 4" - 6" deep recess.</td> </tr> <tr> <td>N2</td> <td>Air gap as required for ventilation of equipment</td> </tr> <tr> <td>N3</td> <td>Hatched area denotes ADA accessible touchscreen area</td> </tr> <tr> <td>N4</td> <td>Height limit of ADA compliant unobstructed forward reach</td> </tr> <tr> <th colspan="2" style="background-color: #4b4b8b; color: white;">Equipment</th> </tr> <tr> <td>EQ1</td> <td>43" Digital Touchscreen (Digital Regulatory Monitor)</td> </tr> <tr> <td>EQ2</td> <td>43" Digital Touchscreen (Departmental Messaging Monitor)</td> </tr> <tr> <td>EQ3</td> <td>Touchscreen Wall Mounts</td> </tr> <tr> <td>EQ4</td> <td>Flat panel wall box(es)</td> </tr> </tbody> </table>	Size		Area:	Varies	Interior Dimensions:	Varies	Drawing Notes		N1	¼" thick stainless steel trim full depth of recess. Trim to protrude ½" from face of wall. Black metal backpan within 4" - 6" deep recess.	N2	Air gap as required for ventilation of equipment	N3	Hatched area denotes ADA accessible touchscreen area	N4	Height limit of ADA compliant unobstructed forward reach	Equipment		EQ1	43" Digital Touchscreen (Digital Regulatory Monitor)	EQ2	43" Digital Touchscreen (Departmental Messaging Monitor)	EQ3	Touchscreen Wall Mounts	EQ4	Flat panel wall box(es)
Size																											
Area:	Varies																										
Interior Dimensions:	Varies																										
Drawing Notes																											
N1	¼" thick stainless steel trim full depth of recess. Trim to protrude ½" from face of wall. Black metal backpan within 4" - 6" deep recess.																										
N2	Air gap as required for ventilation of equipment																										
N3	Hatched area denotes ADA accessible touchscreen area																										
N4	Height limit of ADA compliant unobstructed forward reach																										
Equipment																											
EQ1	43" Digital Touchscreen (Digital Regulatory Monitor)																										
EQ2	43" Digital Touchscreen (Departmental Messaging Monitor)																										
EQ3	Touchscreen Wall Mounts																										
EQ4	Flat panel wall box(es)																										
 <p style="text-align: center;">** Alt Configuration for Locations w/ Limited Space **</p>																											
Notes																											
<ol style="list-style-type: none"> 1. Refer to other subsections of these Design Guidelines for further information. 2. IT requirements and equipment specifications to be coordinated with MCIT. 																											

DD. DEVICE ALIGNMENT	
<p style="text-align: center;">YES NO</p>	Size
	<p>Area: Varies Interior Dimensions: Varies</p>
	Drawing Notes
	Equipment
	<p>EQ1 Fire Strobe EQ2 Thermostat EQ3 Light Switch EQ4 Electrical Outlet</p>
	Signage
	<p>S1 Signage</p>
Notes	
<p>1. Keep walls identified for artwork integration free and clear of any and all electrical devices, room and directional signage, or other potentially distracting items. This includes electrical outlets, telephone/data outlets, light switches, thermostats, fire strobes, furniture, etc.</p>	

EE. KRONOS TIMECLOCK EQUIPMENT	
	Size
	Area: Varies Interior Dimensions: Varies
	Drawing Notes
	N1 Niche painted to match adjacent wall N2 Ventilation air gap around perimeter of timeclock
	Equipment
	EQ1 Kronos Timeclock
	Signage
Notes	
1. Refer to other subsections of these Design Guidelines for further information. 2. IT requirements and equipment specifications to be coordinated with MCIT. 3. Provide blocking as required.	

ERGONOMICS

NYU Langone Health is committed to providing a healthy work environment where our patients, visitors, students and staff are healthy, safe, comfortable and productive. In line with that effort RED+F has developed this subsection in collaboration with NYU Langone’s Occupational & Industrial Orthopedic Center (OIOC) to encourage Architects and Interior Designers to consider user body size, strength and range of motion as well as surrounding environmental factors in the design of our projects. The information provided includes:

1. Ergonomic Design Considerations
2. Helpful Resources

This information does not relieve the Architect or Interior Designer of designing a project that is code compliant and appropriate to the needs of the user. The Architect and Interior Designer may suggest layouts and products not shown in these guidelines if they believe the proposed layouts and products support our mission, design principles, and the design intent of the project.

1. Ergonomic Design Considerations

When applying ergonomics, the Architect and Interior Designer shall consider the nature of the user (physical body dimensions and any individual limitation), the type of task(s) they perform, the layout of the workspace, the work organization, and the equipment/tools used. The primary focus is to create the most efficient and injury-free interface between people and the tools and technology they use.

The Architect and Interior Designer shall consider the following:

- **Human Body** - The Architect and Interior Designer should familiarize themselves with anthropometric data, which provides a good understanding of body measurement variation and movement limitation for the main user population. Having a good grasp of this information will allow the A/E Team to provide for appropriate:
 - **Clearances** (i.e. headroom, elbow room, legroom, etc.) between the body and surrounding objects,

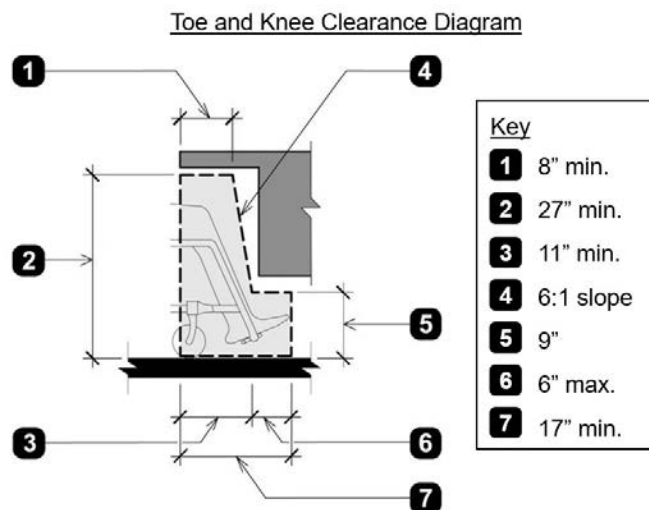

<https://slideplayer.com/slide/3410524/>

- **Reach** towards objects and equipment allowing for placement and adjustment of these items in appropriate reach zones, and

Work Area Reach Zones

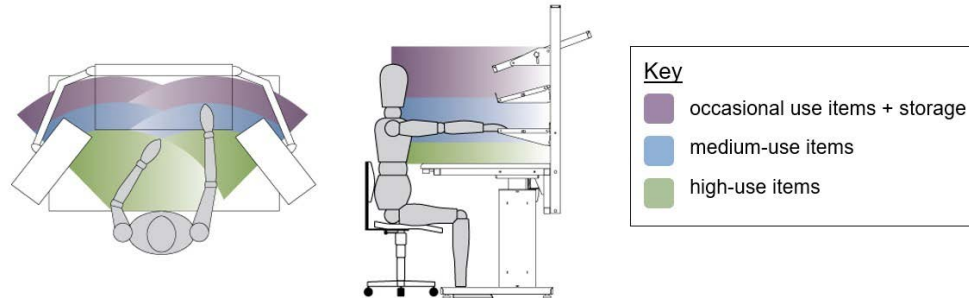

<https://www.bostontec.com/ergonomics/>

- **Posture**, promoting healthy and safe body positioning through responsible furniture layouts and selection.

Standing and Seated Posture

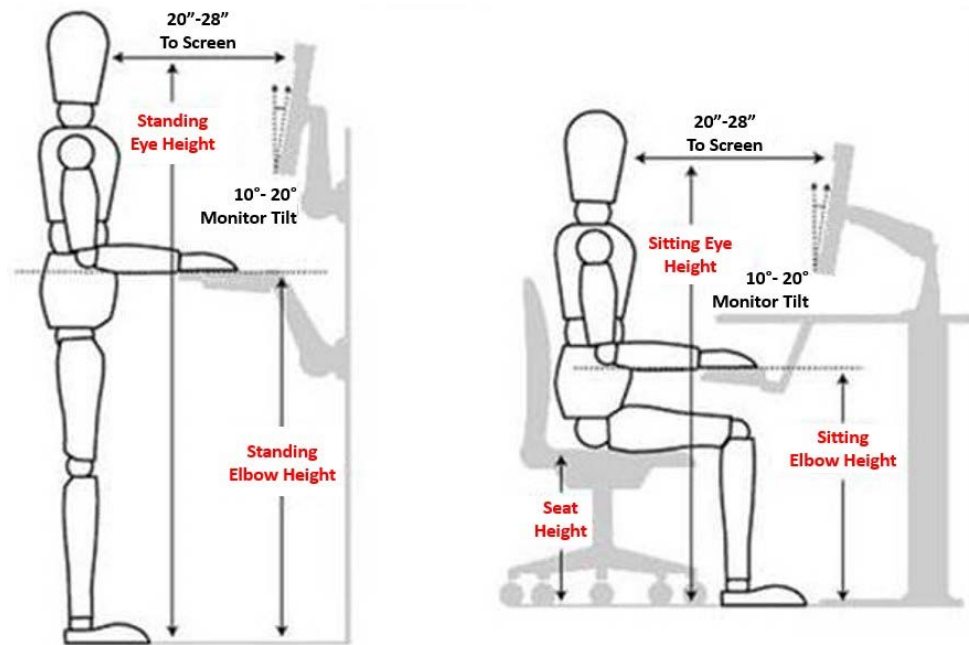

https://www.joionline.net/library/show/ergonomics_in_the_workplace/

Seated Anthropometric Measurements

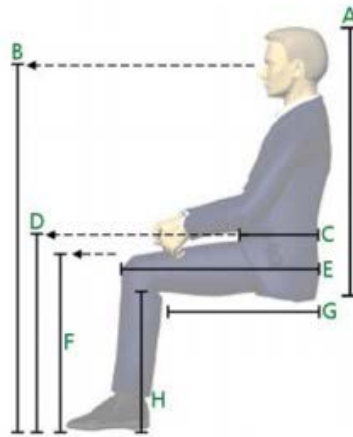
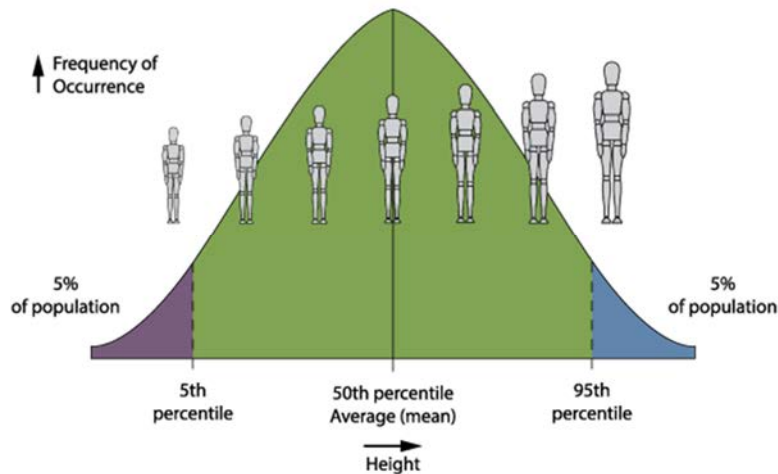

Figure 4. Common anthropometric measurements for the seated position. Use Table 2 for values.

Measurement	Letter	Female 5th – 95th%	Male 5th – 95th%	Overall Range 5th – 95th%
Sitting Height	A	31.3" – 35.8"	33.6" – 38.3"	31.3" – 38.3"
Sitting Eye Height	B	42.6" – 48.8"	46.3" – 52.6"	42.6" – 52.6"
Waist Depth	C	7.3" – 10.7"	7.8" – 11.4"	7.3" – 11.4"
Thigh Clearance	D	21.0" – 24.5"	23.0" – 26.8"	21.0" – 26.8"
Buttock-to-Knee	E	21.3" – 25.2"	22.4" – 26.3"	21.3" – 26.3"
Knee Height	F	19.8" – 23.2"	21.4" – 25.0"	19.8" – 28.0"
Seat Length/Depth	G	16.9" – 20.4"	17.7" – 21.1"	16.9" – 21.1"
Popliteal Height	H	15.0" – 18.1"	16.7" – 19.9"	15.0" – 19.9"
Seat Width	Not Shown	14.5" – 18.0"	13.9" – 17.2"	13.9" – 18.0"

Table 2. Values for 5th to 95th percentile males and females in the seated position used in designing seating. Use Figure 4 for visualization. Data from BIFMA Ergonomics Guidelines, 2002. All measurements are in inches.

Further, Architects and Interior Designers should understand that most designed furniture targets the 5th – 95th percentile of users, or 90% of the user population. This means that the expectation is that their designs meet the needs of 90% of our users. For the 10% of users outside of this range, NYU Langone will assess the workspace, as requested, and provide recommendations to the end user. Architects and Interiors Designers should integrate adjustability and flexibility into their furniture layouts and selections.



<https://www.bostontec.com/ergonomics/>

- **Environment** - The Architect and Interior Designer should keep the following items in mind during design, including relevant code requirements and industry standards:
 - **Light** - To minimize end-user eye strain Architects and Interior Designers should ensure that artificial lighting is not too bright, natural light does not impede the use of equipment such as computer or digital screens, glare is minimized from both artificial and natural sources, and task lighting is provided accordingly. The use of proper lighting equipment and controls as well as window drapes and shades should be integrated into the design.
 - **Ventilation** - Architects and Interior Designers should ensure that users have adequate fresh-air ventilation and heating or cooling so that they feel comfortable when working.
 - **Noise** - Noise can cause stress leading to tensed muscles increasing the risk of injury. Architects and Interior Designers should locate and arrange workstations to allow for quiet surroundings around work areas, wherever possible.

2. Helpful Resources

- Refer to the Environmental Health & Safety subsection of these Design Guidelines for further information.

ROOM FINISHES

In accordance with both our Mission devoted to excellence in patient care, education, and research and our Design Principles of providing timeless designs that are cost effective, efficient, functional and practical, RED+F has developed a palette of typical materials and finishes that we have found to be successful for various spaces at NYU Langone Health.

Our goals in listing these materials and finishes are to:

- Streamline the design process
- Assist the Architect and Interior Designer with specifying materials
- Comply with the Practice Greenhealth Healthcare Without Harm: Safer Chemicals Challenge, eliminating the use of formaldehyde, perfluorinated compounds, polyvinyl chloride (PVC), antimicrobials, and all flame retardants from all materials and finishes
- Create spaces that are timeless, durable, easily maintainable and cost-effective
- Create a consistent NYU Langone brand

The Architect and Interior Designer should use this as a guide for specifying the finishes on NYU Langone capital projects. This information does not relieve the Architect or Interior Designer of specifying materials that are appropriate and code compliant for specific spaces. The Architect and Interior Designer shall consider specifying existing building-specific standards provided they are in line with these Design Guidelines. Also, the Architect and Interior Designer may suggest other materials and finishes if they believe those proposed materials and finishes will support our mission, design principles, and the design intent of the project.

Recommended finishes have been provided for the following spaces:

Space Type	Clinical	Non-Clinical
A. ENTRY		
A1. Entry Vestibule (Street Level)	*	*
A2. Public Lobby / Elevator Lobby / Corridor	*	*
B. CIRCULATION		
B1. Public Elevator Cab	*	*
B2. Patient Transport Elevator Cab (Inpatient Facilities)	*	
B3. Patient Corridor (Inpatient Facilities)	*	
B4. Corridor (Outpatient Facilities)	*	
B5. Service / Freight Elevator Cab	*	*
B6. Service Elevator Lobby / Corridor	*	*

Space Type	Clinical	Non-Clinical
C. RECEPTION / WAITING		
C1. Reception Desk	*	*
C2. Waiting Area		*
C3. Family Lounge (Inpatient Facilities)	*	
C4. Waiting Room (Outpatient Facilities)	*	
D. MEETING		
D1. Auditorium / Lecture Hall / Seminar Room		*
D2. Conference Room	*	*
D3. Training Room		*
E. ADMINISTRATIVE		
E1. Private Office	*	*
E2. Open Work Area	*	*
E3. Nurse Station (Inpatient Facilities)	*	
E4. Medical Assistant Station (Outpatient Facilities)	*	
F. PATIENT		
F1. Patient Room (Inpatient Facilities)	*	
F2. Changing Room (Outpatient Facilities)	*	
F3. Gown Waiting (Outpatient Facilities)	*	
F4. Exam Room (Inpatient Facilities)	*	
F5. Exam Room (Outpatient Facilities)	*	
F6. Procedure Room	*	
F7. Psychiatric Clinical Room	*	
F8. Phlebotomy Lab / Blood Draw (Outpatient Facilities)	*	
G. RESEARCH		
G1. Laboratory		*
G2. Vivarium		*
H. DINING		
H1. Cafeteria (Public Area)	*	*
H2. Food Preparation	*	*
H3. Staff Pantry (with Seating)	*	*
H4. Staff Pantry (without Seating)	*	*

Space Type	Clinical	Non-Clinical
J. STAFF AREAS		
J1. Staff Lounge	*	*
J2. Staff Locker Room	*	*
J3. Lactation Room	*	*
J4. Wellness / Quiet Room	*	*
K. TOILET ROOMS		
K1. Public / Staff Toilet / Patient Toilet (Outpatient Facilities)	*	*
K2. Patient Toilet / Shower (Inpatient Facilities)	*	
L. SUPPORT SPACES		
L1. Clean Utility	*	
L2. Soiled Utility	*	
L3. Storage Room	*	*
L4. Janitor’s Closet	*	*
L5. Shop		*
L6. BDF/IDF Room & Data Center	*	*
L7. Mechanical Equipment Room	*	*
L8. Electrical Equipment Room	*	*

The following finishes are recommended for various spaces at NYU Langone Health. For product specifications refer to the Material Legend subsection of these Design Guidelines.

Cost-saving Alternatives:

The RED+F PM will advise the A/E Design Team if items identified as Cost-saving Alternatives shall be allowed on their project. There may be risks associated with using such items, including the need to repair or replace them more often, but it has been determined they are within acceptable range for use on certain NYU Langone Health projects.

A. ENTRY

A1. ENTRY VESTIBULE (STREET LEVEL)	
Item	Finish
Flooring	Walk-off Carpet
Base	Stainless Steel
Wall Finish	Glass Storefront Specialty Material, incl. metal, glass, stone Wall Covering (level 5 finish) <u>Cost-saving Alternatives:</u> - GWB (level 5 finish), paint (eggshell finish)
Door type/finish	Glass Storefront
Ceiling Material	GWB, paint (flat finish)

A2. PUBLIC LOBBY / ELEVATOR LOBBY / CORRIDOR	
Item	Finish
Flooring	Terrazzo, poured Stone Walk-off Carpet (15-foot min. depth from entry to hard flooring) <u>Cost-saving Alternatives:</u> - Porcelain, tile
Base	Integral, to match flooring material Stainless Steel Wood
Wall Finish	Glass Storefront Specialty Material, incl. glass, acrylic resin, wood, stone <u>Cost-saving Alternatives:</u> - Wall Covering (level 5 finish) - GWB (level 5 finish), paint (eggshell finish)
Door type/finish	Glass Storefront HM, paint (semi-gloss finish), 8'-0" high Wood, 8'-0" high Stainless Steel (elevator doors) <u>Cost-saving Alternatives:</u> - HM, paint (semi-gloss finish), 7'-0" high - Wood, 7'-0" high - HM, Scuffmaster paint (metallic finish; elevator doors)
Door Frame type/finish	HM, paint (semi-gloss finish) Stainless Steel (elevator doors) <u>Cost-saving Alternatives:</u> - HM, paint (semi-gloss finish), knockdown w/ bondo joints - HM, Scuffmaster paint (metallic finish; elevator doors)
Ceiling Material	Specialty Material, incl. wood (acoustic) <u>Cost-saving Alternatives:</u> - GWB, paint (flat finish) - Lay-in, ACT, Ultima
Millwork	See item C1. Reception Desk <u>Cost-saving Alternatives:</u> - Prefab Reception Desk
Countertops / Transaction Tops	See item C1. Reception Desk
Window Sills/Convactor	Solid Surface Painted Metal <u>Cost-saving Alternatives:</u> - Solid Surface, Corian Grade A
Window Treatments	Shade Cloth, 3% opening Trevira Sheers <u>Cost-saving Alternatives:</u> - No Sheers

B. CIRCULATION

B1. PUBLIC ELEVATOR CAB	
Item	Finish
Flooring	Match floor material in adjacent elevator lobby / corridor Stone, tile Rubber, tile Resilient, tile
Base	Integral to wall assembly Stainless Steel
Wall Finish ¹	Specialty Material, incl. metal, glass, acrylic resin (3Form), stone <u>Cost-saving Alternatives:</u> - HPL Laminate
Wall Protection	Crash Rail Bumper Guard (Clinical and Research only)
Door type/finish	Stainless Steel <u>Cost-saving Alternatives:</u> - HM, Scuffmaster paint (metallic finish)
Door Frame type/finish	Stainless Steel <u>Cost-saving Alternatives:</u> - HM, Scuffmaster paint (metallic finish)
Ceiling Material ²	Specialty Material, incl. metal, wood
<ol style="list-style-type: none"> 1. Consult with RED+F PM regarding specialty needs such as the need for wall pad pins/padding. 2. If public elevator is being used as a service elevator as well, maintain highest clear ceiling height possible. 	

B2. PATIENT TRANSPORT ELEVATOR CAB (INPATIENT FACILITIES)	
Item	Finish
Flooring	Match floor material in adjacent elevator lobby / corridor Stone, tile Rubber, tile Resilient, tile
Base	Integral to wall assembly Stainless Steel
Wall Finish	Specialty Material, incl. metal, acrylic resin (3Form) <u>Cost-saving Alternatives:</u> - HPL Laminate
Wall Protection	Crash Rail Bumper Guard
Door type/finish	Stainless Steel <u>Cost-saving Alternatives:</u> - HM, Scuffmaster paint (metallic finish)
Door Frame type/finish	Stainless Steel <u>Cost-saving Alternatives:</u> - HM, Scuffmaster paint (metallic finish)
Ceiling Material ¹	Specialty Material, incl. metal
<ol style="list-style-type: none"> 1. Consider indirect lighting. 	

B3. PATIENT CORRIDOR (INPATIENT FACILITIES)	
Item	Finish
Flooring	Rubber, tile <u>Cost-saving Alternatives:</u> - Resilient, plank - Resilient, tile
Base	Rubber, millwork <u>Cost-saving Alternatives:</u> - Rubber, straight
Wall Finish	GWB (level 4 finish), paint (eggshell finish) Heavy Duty Wall Covering (level 4 finish)
Wall Protection	Corner Guards Rubstrip at IV pole height Handrail, C-S Crash Rail Bumper Guard
Door type/finish	HM, paint (semi-gloss finish), 8'-0" high
Door Frame type/finish	HM, paint (semi-gloss finish)
Door Protection	Kickplate, Stainless Steel
Ceiling Material	Lay-in, ACT Hzone

B4. CORRIDOR (OUTPATIENT FACILITIES)	
Item	Finish
Flooring	Resilient, tile Resilient, plank
Base	Rubber, millwork <u>Cost-saving Alternatives:</u> - Rubber, straight
Wall Finish	GWB (level 4 finish), paint, scrub-resistant (eggshell finish) Heavy Duty Wall Covering (level 4 finish; Xorel) Impact Resistant Wall Covering, Inpro(Ricochet) <u>Cost-saving Alternatives:</u> - GWB (level 4 finish), paint (eggshell finish)
Wall Protection	Corner Guards
Door type/finish	HM, paint (semi-gloss finish), 8'-0" high Wood, 8'-0" high <u>Cost-saving Alternatives:</u> - HM, paint (semi-gloss finish), 7'-0" high - Wood, 7'-0" high
Door Frame type/finish	HM, paint (semi-gloss finish) <u>Cost-saving Alternatives:</u> - HM, paint (semi-gloss finish), knockdown w/ bondo joints
Door Protection	Kickplate, Stainless Steel <u>Cost-saving Alternatives:</u> - None
Ceiling Material	Lay-in, ACT Hzone <u>Cost-saving Alternatives:</u> - Lay-in, ACT Ultima

B5. SERVICE / FREIGHT ELEVATOR CAB	
Item	Finish
Flooring	Rubber, tile
Base	Integral to wall assembly Stainless Steel
Wall Finish ¹	Specialty Material, incl. metal (including diamond plate)
Wall Protection	Crash Rail Bumper Guard
Door type/finish	Stainless Steel <u>Cost-saving Alternatives:</u> - HM, Scuffmaster paint (metallic finish)
Door Frame type/finish	Stainless Steel <u>Cost-saving Alternatives:</u> - HM, Scuffmaster paint (metallic finish)
Ceiling Material ²	Specialty Material, incl. metal <u>Cost-saving Alternatives:</u> - Open
<ol style="list-style-type: none"> 1. Provide wall pad pins/padding. 2. Maintain highest clear ceiling height possible. 	

B6. SERVICE ELEVATOR LOBBY / CORRIDOR	
Item	Finish
Flooring	Rubber, tile <u>Cost-saving Alternatives:</u> - Resilient, tile
Base	Rubber, millwork <u>Cost-saving Alternatives:</u> - Rubber, straight - Rubber, cove (non-clinical facilities only)
Wall Finish	GWB (level 4 finish), paint, scrub-resistant (eggshell finish; on upper portion) <u>Cost-saving Alternatives:</u> - GWB (level 4 finish), paint (eggshell finish; on upper portion)
Wall Protection	Corner Guards Crash Rail Bumper Guard Diamond plate (on lower portion) Stainless Steel sheet (on lower portion) Impact Resistant Wall Covering, Inpro (Ricochet; on lower portion)
Door type/finish	HM, paint (semi-gloss finish), 8'-0" high <u>Cost-saving Alternatives:</u> - HM, paint (semi-gloss finish), 7'-0" high
Door Frame type/finish	HM, paint (semi-gloss finish) <u>Cost-saving Alternatives:</u> - HM, paint (semi-gloss finish), knockdown w/ bondo joints
Door Protection	Kickplate, Stainless Steel
Ceiling Material	Lay-in, ACT, Hzone <u>Cost-saving Alternatives:</u> - Lay-in, ACT, Ultima

C. RECEPTION / WAITING

C1. RECEPTION DESK	
Item	Finish
Millwork (Front Face)	Stone Solid Surface, Corian Engineered Stone Specialty Material, incl. Acrylic (3Form), Decorative Glass <u>Cost-saving Alternatives:</u> - Solid Surface, Corian Grade A - Plastic Laminate, with corner trim
Counter (Transaction)	Stone Solid Surface, Corian Engineered Stone Specialty Material, incl. Acrylic (3Form) <u>Cost-saving Alternatives:</u> - Solid Surface, Corian Grade A - Plastic Laminate (solid thru-color)
Counter (Work)	Stone Solid Surface, Corian Engineered Stone Specialty Material, incl. Acrylic (3Form) <u>Cost-saving Alternatives:</u> - Plastic Laminate (solid thru-color)
Millwork (Base w/ recessed toe kick)	Stainless Steel Solid Surface, Corian Stone <u>Cost-saving Alternatives:</u> - Rubber, millwork, match adj. base height (Johnsonite, Mandalay, # 69 Sterling Silver CG)

C2. WAITING AREA	
Item	Finish
Flooring	Porcelain, tile <u>Cost-saving Alternatives:</u> - Resilient, plank - Resilient, tile - Carpet, tile
Base	Integral, to match floor material Rubber, millwork <u>Cost-saving Alternatives:</u> - Rubber, straight
Wall Finish	Glass Storefront Specialty Material Acoustic Solutions <u>Cost-saving Alternatives:</u> - Wall Covering (level 5 finish) - GWB (level 5 finish), paint (eggshell finish)
Door type/finish	Glass Storefront HM, paint (semi-gloss finish), 8'-0" high Wood, 8'-0" high <u>Cost-saving Alternatives:</u> - HM, paint (semi-gloss finish), 7'-0" high - Wood, 7'-0" high
Door Frame type/finish	HM, paint (semi-gloss finish) <u>Cost-saving Alternatives:</u> - HM, paint (semi-gloss finish), knockdown w/ bondo joints
Ceiling Material	Specialty Material, incl. metal, wood <u>Cost-saving Alternatives:</u> - Lay-in, ACT, Ultima
Millwork (incl. Privacy Screens at Financial Counselor Desks)	See Item C1. Reception Desk <u>Cost-saving Alternatives:</u> - Prefab Reception Desk - Prefab Casework (see Furniture subsection)
Countertops / Transaction Tops	See Item C1. Reception Desk
Window Sills/Convactor	Solid Surface Painted Metal <u>Cost-saving Alternatives:</u> - Solid Surface, Corian Grade A
Window Treatments	Shade Cloth, 3% opening Trevira Sheers <u>Cost-saving Alternatives:</u> - No Sheers
1. TV monitors are not allowed . Monitors for both Digital Regulatory Signage and Departmental Messaging are allowed .	

C3. FAMILY LOUNGE (INPATIENT FACILITIES)	
Item	Finish
Flooring	Rubber, tile <u>Cost-saving Alternatives:</u> - Resilient, plank - Resilient, tile
Base	Rubber, millwork <u>Cost-saving Alternatives:</u> - Rubber, straight
Wall Finish ¹	Wall Covering (level 5 finish) Glass <u>Cost-saving Alternatives:</u> - GWB (level 5 finish), paint (eggshell finish)
Door type/finish	HM, paint (semi-gloss finish), 8'-0" high
Door Frame type/finish	HM, paint (semi-gloss finish)
Ceiling Material	Lay-in, ACT Hzone
Millwork	Plastic Laminate (solid thru-color) Prefab Casework (see Furniture subsection)
Countertops ²	Solid Surface Engineered Stone <u>Cost-saving Alternatives:</u> - Solid Surface, Corian Grade A
Window Sills/Convactor	Solid Surface Painted Metal <u>Cost-saving Alternatives:</u> - Solid Surface, Corian Grade A
Window Treatments	Shade Cloth, 3% openness Trevira Sheers
<p>1. TV monitors are not allowed. Monitors for both Digital Regulatory Signage and Departmental Messaging are allowed.</p> <p>2. Turn the countertop material 4" up the back and side walls.</p>	

C4. WAITING ROOM (OUTPATIENT FACILITIES)	
Item	Finish
Flooring	Rubber, tile <u>Cost-saving Alternatives:</u> - Resilient, plank - Resilient, tile - Carpet, tile
Base	Rubber, millwork <u>Cost-saving Alternatives:</u> - Rubber, straight
Wall Finish ¹	Wall Covering (level 5 finish) Glass <u>Cost-saving Alternatives:</u> - GWB (level 5 finish), paint (eggshell finish)
Door type/finish	HM, paint (semi-gloss finish), 8'-0" high Wood, 8'-0" high Glass <u>Cost-saving Alternatives:</u> - HM, paint (semi-gloss finish), 7'-0" high - Wood, 7'-0" high
Door Frame type/finish	HM, paint (semi-gloss finish) <u>Cost-saving Alternatives:</u> - HM, paint (semi-gloss finish), knockdown w/ bondo joints
Ceiling Material	Lay-in, ACT Hzone <u>Cost-saving Alternatives:</u> - Lay-in, ACT Ultima
Millwork	Plastic Laminate Prefab Casework (see Furniture subsection)
Countertops ²	Solid Surface Engineered Stone <u>Cost-saving Alternatives:</u> - Solid Surface, Corian Grade A
Window Sills/Convactor	Solid Surface Painted Metal <u>Cost-saving Alternatives:</u> - Solid Surface, Corian Grade A - Plastic Laminate
Window Treatments	Shade Cloth, 3% openness Trevira Sheers
<p>1. TV monitors are not allowed. Monitors for both Digital Regulatory Signage and Departmental Messaging are allowed.</p> <p>2. Turn the countertop material 4" up the back and side walls.</p>	

D. MEETING

D1. AUDITORIUM / LECTURE HALL / SEMINAR ROOM	
Item	Finish
Flooring	Wood (stage) Rubber, sheet (under chairs) Carpet (in circulation areas only) <u>Cost-saving Alternatives:</u> - Resilient, sheet (under chairs)
Base	Wood Stainless Steel <u>Cost-saving Alternatives:</u> - Rubber, millwork
Wall Finish	Specialty Material, incl. wood Acoustic Solutions <u>Cost-saving Alternatives:</u> - Acoustic Solutions, felt - Wall Covering (level 5 finish) - GWB (level 5 finish), paint (eggshell finish)
Door type/finish	Wood , 8'-0" high HM, paint (semi-gloss finish), 8'-0" high <u>Cost-saving Alternatives:</u> - Wood, 7'-0" high - HM, paint (semi-gloss finish), 7'-0" high
Door Frame type/finish	HM, paint (semi-gloss finish) <u>Cost-saving Alternatives:</u> - HM, paint (semi-gloss finish), knockdown w/ bondo joints
Ceiling Material	Specialty Material, incl. wood (acoustic) <u>Cost-saving Alternatives:</u> - GWB, paint (flat finish) - Lay-in, ACT
Millwork	Wood <u>Cost-saving Alternatives:</u> - Plastic Laminate (solid thru-color) - Prefab Casework (see Furniture subsection) - Prefab Lectern (see Furniture subsection)
Countertops	Solid Surface Engineered Stone <u>Cost-saving Alternatives:</u> - Solid Surface, Corian Grade A
Window Sills/Convactor	Solid Surface Painted Metal <u>Cost-saving Alternatives:</u> - Solid Surface, Corian Grade A

D2. CONFERENCE ROOM	
Item	Finish
Flooring	Carpet, tile
Base	Rubber, millwork Rubber, straight
Wall Finish ¹	Specialty Material, incl. wood Acoustic Solutions Demountable Partition <u>Cost-saving Alternatives:</u> - Wall Covering (level 5 finish) - GWB (level 5 finish), paint (eggshell finish)
Door type/finish	Wood, 8'-0" high Demountable Partition HM, paint (semi-gloss finish), 8'-0" high <u>Cost-saving Alternatives:</u> - Wood, 7'-0" high - HM, paint (semi-gloss finish), 7'-0" high
Door Frame type/finish	HM, paint (semi-gloss finish) Demountable Partition <u>Cost-saving Alternatives:</u> - HM, paint (semi-gloss finish), knockdown w/ bondo joints
Ceiling Material	Specialty Material, incl. wood GWB, paint (flat finish) <u>Cost-saving Alternatives:</u> - Lay-in, ACT
Millwork	Wood veneer Plastic Laminate <u>Cost-saving Alternatives:</u> - Prefab Casework (see Furniture subsection) - Prefab Credenza (see Furniture subsection)
Countertops	Solid Surface Engineered Stone <u>Cost-saving Alternatives:</u> - Solid Surface, Corian Grade A
Window Sills/Convactor	Solid Surface Painted Metal <u>Cost-saving Alternatives:</u> - Solid Surface, Corian Grade A - Plastic Laminate
Window Treatments	Shade Cloth, 3% openness Trevira Sheers <u>Cost-saving Alternatives:</u> - No Sheers

D3. TRAINING ROOM	
Item	Finish
Flooring	Carpet, tile
Base	Rubber, millwork Rubber, straight
Wall Finish	Wall Covering (level 5 finish) <u>Cost-saving Alternatives:</u> - GWB (level 5 finish), paint (eggshell finish)
Door type/finish	HM, paint (semi-gloss finish), 8'-0" high Wood, 8'-0" high <u>Cost-saving Alternatives:</u> - HM, paint (semi-gloss finish), 7'-0" high - Wood, 7'-0" high
Door Frame type/finish	HM, paint (semi-gloss finish) <u>Cost-saving Alternatives:</u> - HM, paint (semi-gloss finish), knockdown w/ bondo joints
Ceiling Material	Lay-in, ACT

E. ADMINISTRATIVE

E1. PRIVATE OFFICE	
Item	Finish
Flooring	Carpet, tile
Base	Rubber, millwork Rubber, straight
Wall Finish	Demountable Partition <u>Cost-saving Alternatives:</u> - GWB (level 4 finish), paint (eggshell finish)
Door type/finish ¹	Wood, 8'-0" high Demountable Partition <u>Cost-saving Alternatives:</u> - Wood, 7'-0" high
Door Frame type/finish	HM, paint (semi-gloss finish) Demountable Partition <u>Cost-saving Alternatives:</u> - HM, paint (semi-gloss finish), knockdown w/ bondo joints
Ceiling Material	Lay-in, ACT Ultima
Millwork	Case Goods (see Furniture subsection)
Window Sills/Convactor	Solid Surface Painted Metal <u>Cost-saving Alternatives:</u> - Solid Surface, Corian Grade A - Plastic Laminate
Window Treatments	Shade Cloth, 3% opening
1. Provide coat hooks. Refer to Building Accessories subsection of these Design Guidelines.	

E2. OPEN WORK AREA	
Item	Finish
Flooring	Carpet, tile Resilient, tile
Base	Rubber, millwork Rubber, straight <u>Cost-saving Alternatives:</u> - Rubber, cove
Wall Finish	GWB (level 4 finish), paint (eggshell finish)
Ceiling Material	Lay-in, ACT, Ultima
Millwork	Plastic Laminate Workstations (see Furniture subsection)
Countertops	Solid Surface <u>Cost-saving Alternatives:</u> - Plastic Laminate
Window Sills/Convactor	Solid Surface Painted Metal <u>Cost-saving Alternatives:</u> - Solid Surface, Corian Grade A - Plastic Laminate
Window Treatments	Shade Cloth, 3% opening

E3. NURSE STATION (INPATIENT FACILITIES)	
Item	Finish
Flooring	Rubber, tile <u>Cost-saving Alternatives:</u> - Resilient, plank - Resilient, tile
Base	Rubber, millwork <u>Cost-saving Alternatives:</u> - Rubber, straight
Wall Finish	GWB (level 4 finish), paint (eggshell finish)
Ceiling Material	Lay-in, ACT Hzone
Millwork	Plastic Laminate (solid thru-color) Specialty Material Prefab Casework (see Furniture subsection) <u>Cost-saving Alternatives:</u> - Workstation Systems Furniture
Countertops	Solid Surface Engineered Stone <u>Cost-saving Alternatives:</u> - Solid Surface, Corian Grade A

E4. MEDICAL ASSISTANT STATION (OUTPATIENT FACILITIES)	
Item	Finish
Flooring	Resilient, plank, match adjacent corridor Resilient, tile, match adjacent corridor
Base	Rubber, millwork, match adjacent corridor <u>Cost-saving Alternatives:</u> - Rubber, straight, match adjacent corridor
Wall Finish	GWB (level 4 finish), paint, scrub-resistant (eggshell finish) Heavy Duty Wall Covering (level 4 finish; Xorel) <u>Cost-saving Alternatives:</u> - GWB (level 4 finish), paint (eggshell finish)
Ceiling Material	Specialty Material, incl. metal Lay-in, ACT Hzone <u>Cost-saving Alternatives:</u> - Lay-in, ACT Ultima
Millwork	Plastic Laminate Prefab Casework (see Furniture subsection) <u>Cost-saving Alternatives:</u> - Workstation Systems Furniture
Countertops ¹	Solid Surface <u>Cost-saving Alternatives:</u> - Solid Surface, Corian Grade A

1. Confirm countertop height requirements (seated versus standing).

F. PATIENT

F1. PATIENT ROOM (INPATIENT FACILITIES)	
Item	Finish
Flooring ¹	Rubber, tile <u>Cost-saving Alternatives:</u> - Resilient, plank - Resilient, tile
Base	Rubber, millwork <u>Cost-saving Alternatives:</u> - Rubber, straight
Wall Finish	GWB (level 4 finish), paint (eggshell finish)
Wall Protection	Impact Resistant Wall Covering (headwall ²) Rubstrip, C-S (footwall) <u>Cost-saving Alternatives:</u> - Heavy Duty Wall Covering (level 4 finish; headwall ² ; Xorel) - Rubstrip, C-S, where deemed necessary
Door type/finish	Hollow Metal (HM), paint (semi-gloss finish), 8'-0" high
Door Frame type/finish	HM, paint (semi-gloss finish)
Door Protection	Kickplate, Stainless Steel
Ceiling Material	Lay-in, ACT Hzone
Millwork	Wood <u>Cost-saving Alternatives:</u> - Plastic Laminate (solid thru-color) - Prefab Casework (see Furniture subsection)
Countertops ³	Solid Surface Engineered Stone <u>Cost-saving Alternatives:</u> - Solid Surface, Corian Grade A
Window Sills/Convactor	Solid Surface Painted Metal <u>Cost-saving Alternatives:</u> - Solid Surface, Corian Grade A
Window Treatments	Shade Cloth, 3% opening and Shade Cloth, blackout Use double roller
<ol style="list-style-type: none"> 1. Provide L-bracket on floor as a means to bedstop to protect the headwall. 2. Provide impact resistant gypsum board or other impact resistant substrate at headwall. 3. Turn the countertop material 4" up the back and side walls. 	

F2. CHANGING ROOM (OUTPATIENT FACILITIES)	
Item	Finish
Flooring	Resilient, tile Resilient, plank
Base	Rubber, millwork <u>Cost-saving Alternatives:</u> - Rubber, straight
Wall Finish	GWB (level 4 finish), paint (eggshell finish)
Door type/finish ¹	HM, paint (semi-gloss finish), 8'-0" high Wood, 8'-0" high <u>Cost-saving Alternatives:</u> - HM, paint (semi-gloss finish), 7'-0" high - Wood, 7'-0" high
Door Frame type/finish	HM, paint (semi-gloss finish) <u>Cost-saving Alternatives:</u> - HM, paint (semi-gloss finish), knockdown w/ bondo joints
Ceiling Material	Lay-in, ACT Hzone <u>Cost-saving Alternatives:</u> - Lay-in, ACT Ultima
Millwork	Plastic Laminate w/ Laundry Hamper, if applicable Prefab Casework w/ Laundry Hamper, if applicable (see Furniture subsection) HPL Lockers, if applicable (see Furniture subsection)
Countertops	Solid Surface <u>Cost-saving Alternatives:</u> - Solid Surface, Corian Grade A
Curtains	Cubicle Curtain, if applicable
1. Provide coat hooks. Refer to Building Accessories subsection of these Design Guidelines.	

F3. GOWN WAITING (OUTPATIENT FACILITIES)	
Item	Finish
Flooring	Resilient, tile Resilient, plank
Base	Rubber, millwork <u>Cost-saving Alternatives:</u> - Rubber, straight
Wall Finish	GWB (level 4 finish), paint (eggshell finish)
Door type/finish ¹	HM, paint (semi-gloss finish), 8'-0" high Wood, 8'-0" high <u>Cost-saving Alternatives:</u> - HM, paint (semi-gloss finish), 7'-0" high - Wood, 7'-0" high
Door Frame type/finish	HM, paint (semi-gloss finish) <u>Cost-saving Alternatives:</u> - HM, paint (semi-gloss finish), knockdown w/ bondo joints
Ceiling Material	Lay-in, ACT Hzone <u>Cost-saving Alternatives:</u> - Lay-in, ACT Ultima
Millwork	Plastic Laminate w/ Laundry Hamper, if applicable Prefab Casework w/ Laundry Hamper, if applicable (see Furniture subsection) HPL Lockers, if applicable (see Furniture subsection)
Countertops	Solid Surface <u>Cost-saving Alternatives:</u> - Solid Surface, Corian Grade A
1. Provide coat hooks. Refer to Building Accessories subsection of these Design Guidelines.	

F4. EXAM ROOM (INPATIENT FACILITIES)	
Item	Finish
Flooring	Rubber, tile <u>Cost-saving Alternatives:</u> - Resilient, plank - Resilient, tile
Base	Rubber, millwork <u>Cost-saving Alternatives:</u> - Rubber, straight
Wall Finish	GWB (level 4 finish), paint (eggshell finish)
Wall Protection	Rubstrip <u>Cost-saving Alternatives:</u> - Rubstrip, where deemed necessary
Door type/finish ¹	HM, paint (semi-gloss finish), 8'-0" high
Door Frame type/finish	HM, paint (semi-gloss finish)
Door Protection	Kickplate, Stainless Steel
Ceiling Material	Lay-in, ACT Hzone
Millwork	Plastic Laminate (solid thru-color) Prefab Casework (see Furniture subsection)
Countertops ²	Solid Surface w/ full height backsplash Engineered Stone w/ full height backsplash <u>Cost-saving Alternatives:</u> - Solid Surface, Corian Grade A w/ full height backsplash
Window Sills/Convactor	Solid Surface Painted Metal <u>Cost-saving Alternatives:</u> - Solid Surface, Corian Grade A
Window Treatments	Shade Cloth, 3% opening and Shade Cloth, blackout Use double roller
<p>1. Provide coat hooks. Refer to Building Accessories subsection of these Design Guidelines.</p> <p>2. Turn the countertop material 4" up the back and side walls.</p>	

F5. EXAM ROOM (OUTPATIENT FACILITIES)	
Item	Finish
Flooring	Resilient, tile Resilient, plank
Base	Rubber, millwork <u>Cost-saving Alternatives:</u> - Rubber, straight
Wall Finish	GWB (level 4 finish), paint (eggshell finish)
Wall Protection	Rubstrip, where deemed necessary
Door type/finish ¹	HM, paint (semi-gloss finish), 8'-0" high Wood, 8'-0" high <u>Cost-saving Alternatives:</u> - HM, paint (semi-gloss finish), 7'-0" high - Wood, 7'-0" high
Door Frame type/finish	HM, paint (semi-gloss finish) <u>Cost-saving Alternatives:</u> - HM, paint (semi-gloss finish), knockdown w/ bondo joints
Ceiling Material	Lay-in, ACT Hzone <u>Cost-saving Alternatives:</u> - Lay-in, ACT Ultima
Millwork	Prefab Casework (see Furniture subsection)
Countertops ²	Solid Surface w/ full height backsplash <u>Cost-saving Alternatives:</u> - Solid Surface, Corian Grade A w/ 4" backsplash
Window Sills/Convactor	Solid Surface Painted Metal <u>Cost-saving Alternatives:</u> - Solid Surface, Corian Grade A - Plastic Laminate
Window Treatments	Shade Cloth, 3% opening and Shade Cloth, blackout Use double roller
<p>1. Provide coat hooks. Refer to Building Accessories subsection of these Design Guidelines.</p> <p>2. Turn the countertop material 4" up the back and side walls.</p>	

F6. PROCEDURE ROOM	
Item	Finish
Flooring	Rubber, sheet, chemically welded Rubber, tile, chemically welded Resilient, sheet <u>Cost-saving Alternatives:</u> - Resilient, sheet, Gerflor (Mipolam Symbioz, For Operating Rooms only provide #6018 Ushuaia under operating table, #6009 Grey Stone at perimeter)
Base	Integral, sanitary cove base
Wall Finish	GWB (level 4 finish), paint, scrub-resistant (eggshell finish)
Wall Protection	Solid Surface Sheet, Inpro (Endurant Bioprism) <u>Cost-saving Alternatives:</u> - None (Outpatient Facilities)
Door type/finish	HM, paint (semi-gloss finish), 8'-0" high <u>Cost-saving Alternatives:</u> - HM, paint (semi-gloss finish), 7'-0" high (Outpatient Facilities)
Door Frame type/finish	HM, paint (semi-gloss finish) <u>Cost-saving Alternatives:</u> - HM, paint (semi-gloss finish), knockdown w/ bondo joints (Outpatient Facilities)
Door Protection	Kickplate, Stainless Steel
Ceiling Material ¹	GWB, paint, scrub-resistant (eggshell finish) Lay-in, ACT Clean Room VL Modular, BASX (Operating Rooms)
Millwork	Stainless Steel <u>Cost-saving Alternatives:</u> - Prefab Casework (see Furniture subsection) - Plastic Laminate (Outpatient Facilities)
Countertops ²	Stainless Steel <u>Cost-saving Alternatives:</u> - Solid Surface, Corian Grade A (Outpatient Facilities) - Plastic Laminate (Outpatient Facilities)
<p>1. Refer to item #4 in the Miscellaneous subsection of these Design Guidelines for further information.</p> <p>2. Provide full height backsplash integral with the countertop surface.</p>	

F7. PSYCHIATRIC CLINICAL ROOM	
Item	Finish
Flooring	Rubber, sheet, chemically welded Rubber, tile, chemically welded Resilient, sheet <u>Cost-saving Alternatives:</u> - Resilient, sheet, Gerflor (Mipolam Symbioz)
Base	Integral, sanitary cove base
Wall Finish	Impact Resistant GWB (level 4 finish), paint, scrub-resistant (eggshell finish)
Door type/finish	HM, paint (semi-gloss finish), 8'-0" high
Door Frame type/finish	HM, paint (semi-gloss finish)
Door Protection	Kickplate, Stainless Steel
Ceiling Material	GWB, paint, scrub-resistant

F8. PHLEBOTOMY LAB / BLOOD DRAW (OUTPATIENT FACILITIES)	
Item	Finish
Flooring	Resilient, tile Resilient, plank
Base	Rubber, straight <u>Cost-saving Alternatives:</u> - Rubber, straight
Wall Finish	GWB (level 4 finish), paint (eggshell finish)
Wall Protection	Rubstrip <u>Cost-saving Alternatives:</u> - Rubstrip, where deemed necessary
Door type/finish	HM, paint (semi-gloss finish), 8'-0" high Wood, 8'-0" high <u>Cost-saving Alternatives:</u> - HM, paint (semi-gloss finish), 7'-0" high - Wood, 7'-0" high
Door Frame type/finish	HM, paint (semi-gloss finish) <u>Cost-saving Alternatives:</u> - HM, paint (semi-gloss finish), knockdown w/ bondo joints
Ceiling Material	Lay-in, ACT Hzone <u>Cost-saving Alternatives:</u> - Lay-in, ACT Ultima
Millwork	Prefab Casework (see Furniture subsection)
Countertops	Solid Surface w/ full height backsplash <u>Cost-saving Alternatives:</u> - Solid Surface, Corian Grade A w/ full height backsplash
Window Sills/Convactor	Solid Surface Painted Metal <u>Cost-saving Alternatives:</u> - Solid Surface, Corian Grade A - Plastic Laminate
Window Treatments	Shade Cloth, 3% opening and Shade Cloth, blackout Use double roller

G. RESEARCH

G1. LABORATORY	
Item	Finish
Flooring ¹	Rubber, tile Resilient, tile
Base	Rubber, millwork Rubber, straight <u>Cost-saving Alternatives:</u> - Rubber, cove
Wall Finish	GWB (level 4 finish), paint (eggshell finish)
Door type/finish	HM, paint (semi-gloss finish), 8'-0" high <u>Cost-saving Alternatives:</u> - HM, paint (semi-gloss finish), 7'-0" high
Door Frame type/finish	HM, paint (semi-gloss finish) <u>Cost-saving Alternatives:</u> - HM, paint (semi-gloss finish), knockdown w/ bondo joints
Ceiling Material	Lay-in, ACT, Hzone GWB, paint (flat finish)
Lab Casework	Countertops: Specialty Material, Phenolic Resin Millwork: Wood or Stainless Steel Tack panel: Wall Covering (Carnegie, Xorel)
1. Consider function of lab when selecting flooring (i.e. chemicals being used).	

G2. VIVARIUM	
Item	Finish
Flooring	Concrete Coating, Fluid-Applied (typical rooms)
Base	Integral, sanitary cove base
Wall Finish	Specialty Material, incl. fiberglass-reinforced composite panel GWB (level 4 finish), paint, scrub-resistant (eggshell finish)
Door type/finish	Stainless Steel
Door Frame type/finish	Stainless Steel
Door Protection	Aluminum plate
Ceiling Material	Specialty Material, incl. fiberglass-reinforced panel GWB, paint, scrub-resistant (eggshell finish)

H. DINING

H1. CAFETERIA (PUBLIC AREA)	
Item	Finish
Flooring	Terrazzo, poured Porcelain, tile <u>Cost-saving Alternatives:</u> - Resilient, tile
Base	Integral, to match floor material Integral, sanitary cove base <u>Cost-saving Alternatives:</u> - Rubber, millwork - Rubber, straight
Wall Finish	Glass Storefront (at Entry) Specialty Material, incl. wood, glass Glass, tile (level 2 finish) <u>Cost-saving Alternatives:</u> - Porcelain, tile (level 2 finish) - Wall Covering (level 5 finish) - GWB (level 5 finish), paint (eggshell finish)
Door type/finish	Glass Storefront Stainless Steel, 8'-0" high HM, paint (semi-gloss finish), 8'-0" high <u>Cost-saving Alternatives:</u> - HM, paint (semi-gloss finish), 7'-0"
Door Frame type/finish	Stainless Steel HM, paint (semi-gloss finish) <u>Cost-saving Alternatives:</u> - HM, paint (semi-gloss finish), knockdown w/ bondo joints
Door Protection	Kickplate, Stainless Steel <u>Cost-saving Alternatives:</u> - No Kickplate
Ceiling Material	Specialty Material, incl. wood <u>Cost-saving Alternatives:</u> - GWB, paint (flat finish) - Lay-in, ACT
Millwork	Stainless Steel <u>Cost-saving Alternatives:</u> - Plastic Laminate
Countertops ¹	Solid Surface <u>Cost-saving Alternatives:</u> - Solid Surface, Corian Grade A (at areas w/ sink) - Stainless Steel (at areas w/o sink)
Window Sills/Convactor	Solid Surface Painted Metal <u>Cost-saving Alternatives:</u> - Solid Surface, Corian Grade A
Window Treatments	Shade Cloth, 3% opening
1. Turn the countertop material 4" up the back and side walls.	

H2. FOOD PREPARATION	
Item	Finish
Flooring	Quarry, tile Concrete Coating, Fluid-Applied <u>Cost-saving Alternatives:</u> - Resilient, sheet
Base	Quarry, cove Integral, sanitary cove base <u>Cost-saving Alternatives:</u> - Integral, to match floor material
Wall Finish	GWB (level 4 finish), paint, scrub-resistant (eggshell finish)
Door type/finish	HM, paint (semi-gloss finish), 8'-0" high <u>Cost-saving Alternatives:</u> - HM, paint (semi-gloss finish), 7'-0" high
Door Frame type/finish	HM, paint (semi-gloss finish) <u>Cost-saving Alternatives:</u> - HM, paint (semi-gloss finish), knockdown w/ bondo joints
Door Protection	Kickplate, Stainless Steel
Ceiling Material	Lay-in, ACT, Hzone
Millwork	Stainless Steel
Countertops ¹	Solid Surface <u>Cost-saving Alternatives:</u> - Stainless Steel
1. Turn the countertop material 4" up the back and side walls.	

H3. STAFF PANTRY (WITH SEATING)	
Item	Finish
Flooring	Porcelain, tile Rubber, tile <u>Cost-saving Alternatives:</u> - Resilient, tile - Resilient, plank
Base	Integral, to match flooring material Rubber, millwork Rubber, straight <u>Cost-saving Alternatives:</u> - Rubber, cove
Wall Finish	Wall Covering (level 5 finish) Specialty Material, Glass (backsplash) Glass, tile (level 2 finish; backsplash) Porcelain, tile (level 2 finish; backsplash) <u>Cost-saving Alternatives:</u> - GWB (level 4 finish), paint (eggshell finish) - Ceramic, tile (level 2 finish; backsplash)
Door type/finish	HM, paint (semi-gloss finish), 8'-0" high Wood, 8'-0" high <u>Cost-saving Alternatives:</u> - HM, paint (semi-gloss finish), 7'-0" high - Wood, 7'-0" high
Door Frame type/finish	HM, paint (semi-gloss finish) <u>Cost-saving Alternatives:</u> - HM, paint (semi-gloss finish), knockdown w/ bondo joints
Door Protection	Kickplate, Stainless Steel <u>Cost-saving Alternatives:</u> - No Kickplate
Ceiling Material	Lay-in, ACT, Ultima
Millwork	Plastic Laminate <u>Cost-saving Alternatives:</u> - Prefab Casework (see Furniture subsection)
Countertops ¹	Solid Surface <u>Cost-saving Alternatives:</u> - Solid Surface, Corian Grade A
Window Sills/Convactor	Solid Surface Painted Metal <u>Cost-saving Alternatives:</u> - Solid Surface, Corian Grade A - Plastic Laminate
Window Treatments	Shade Cloth, 3% opening

1. Turn the countertop material 4" up the back and side walls.

H4. STAFF PANTRY (WITHOUT SEATING)	
Item	Finish
Flooring	Rubber, tile <u>Cost-saving Alternatives:</u> - Resilient, tile - Resilient, plank
Base	Rubber, millwork Rubber, straight <u>Cost-saving Alternatives:</u> - Rubber, cove
Wall Finish	GWB (level 4 finish), paint (eggshell finish) Specialty Material, Glass (backsplash) Glass, tile (level 2 finish; backsplash) <u>Cost-saving Alternatives:</u> - Ceramic, tile (level 2 finish; backsplash)
Door type/finish	HM, paint (semi-gloss finish), 8'-0" high Wood, 8'-0" high <u>Cost-saving Alternatives:</u> - HM, paint (semi-gloss finish), 7'-0" high - Wood, 7'-0" high
Door Frame type/finish	HM, paint (semi-gloss finish) <u>Cost-saving Alternatives:</u> - HM, paint (semi-gloss finish), knockdown w/ bondo joints
Door Protection	Kickplate, Stainless Steel <u>Cost-saving Alternatives:</u> - No Kickplate
Ceiling Material	Lay-in, ACT, Ultima
Millwork	Plastic Laminate <u>Cost-saving Alternatives:</u> - Prefab Casework (see Furniture subsection)
Countertops ¹	Solid Surface <u>Cost-saving Alternatives:</u> - Solid Surface, Corian Grade A
Window Sills/Convactor	Solid Surface Painted Metal <u>Cost-saving Alternatives:</u> - Solid Surface, Corian Grade A - Plastic Laminate
Window Treatments	Shade Cloth, 3% opening
1. Turn the countertop material 4" up the back and side walls.	

J. STAFF AREAS

J1. STAFF LOUNGE	
Item	Finish
Flooring	Rubber, tile <u>Cost-saving Alternatives:</u> - Resilient, tile - Resilient, plank
Base	Rubber, millwork Rubber, straight <u>Cost-saving Alternatives:</u> - Rubber, cove
Wall Finish	Demountable Partition Wall Covering (level 5 finish) <u>Cost-saving Alternatives:</u> - GWB (level 4 finish), paint (eggshell finish)
Door type/finish	HM, paint (semi-gloss finish), 8'-0" high Wood, 8'-0" high Demountable Partition <u>Cost-saving Alternatives:</u> - HM, paint (semi-gloss finish), 7'-0" high - Wood, 7'-0" high
Door Frame type/finish	HM, paint (semi-gloss finish) Demountable Partition <u>Cost-saving Alternatives:</u> - HM, paint (semi-gloss finish), knockdown w/ bondo joints
Door Protection	Kickplate, Stainless Steel <u>Cost-saving Alternatives:</u> - No Kickplate
Ceiling Material	Lay-in, ACT, Ultima
Millwork	Plastic Laminate <u>Cost-saving Alternatives:</u> - Prefab Casework (see Furniture subsection)
Countertops ¹	Solid Surface <u>Cost-saving Alternatives:</u> - Solid Surface, Corian Grade A
Window Sills/Convactor	Solid Surface Painted Metal <u>Cost-saving Alternatives:</u> - Solid Surface, Corian Grade A - Plastic Laminate
Window Treatments	Shade Cloth, 3% opening
1. Turn the countertop material 4" up the back and side walls.	

J2. STAFF LOCKER ROOM	
Item	Finish
Flooring	Rubber, tile <u>Cost-saving Alternatives:</u> - Resilient, tile - Resilient, plank
Base	Rubber, millwork Rubber, straight <u>Cost-saving Alternatives:</u> - Rubber, cove
Wall Finish ¹	GWB (level 4 finish), paint (eggshell finish)
Door type/finish	HM, paint (semi-gloss finish), 8'-0" high <u>Cost-saving Alternatives:</u> - HM, paint (semi-gloss finish), 7'-0" high
Door Frame type/finish	HM, paint (semi-gloss finish) <u>Cost-saving Alternatives:</u> - HM, paint (semi-gloss finish), knockdown w/ bondo joints
Door Protection	Kickplate, Stainless Steel <u>Cost-saving Alternatives:</u> - No Kickplate
Ceiling Material	Lay-in, ACT Hzone
Millwork	Lockers (see Furniture subsection)
Countertops ²	Solid Surface <u>Cost-saving Alternatives:</u> - Solid Surface, Corian Grade A
Window Sills/Convactor	Solid Surface Painted Metal <u>Cost-saving Alternatives:</u> - Solid Surface, Corian Grade A - Plastic Laminate
Window Treatments	Shade Cloth, 3% opening
<ol style="list-style-type: none"> 1. Provide coat hooks. Refer to Building Accessories subsection of these Design Guidelines. 2. Turn the countertop material 4" up the back and side walls. 	

J3. LACTATION ROOM	
Item	Finish
Flooring	Resilient, tile Resilient, plank
Base	Rubber, millwork Rubber, straight <u>Cost-saving Alternatives:</u> - Rubber, cove
Wall Finish	GWB (level 4 finish), paint (eggshell finish) Wall Covering (level 5 finish)
Door type/finish ¹	HM, paint (semi-gloss finish), 8'-0" high Wood, 8'-0" high <u>Cost-saving Alternatives:</u> - HM, paint (semi-gloss finish), 7'-0" high - Wood, 7'-0" high
Door Frame type/finish	HM, paint (semi-gloss finish) <u>Cost-saving Alternatives:</u> - HM, paint (semi-gloss finish), knockdown w/ bondo joints
Ceiling Material	Lay-in, ACT, Hzone
Millwork	Wood <u>Cost-saving Alternatives:</u> - Plastic Laminate - Prefab Casework (see Furniture subsection)
Countertops ²	Solid Surface Engineered Stone <u>Cost-saving Alternatives:</u> - Solid Surface, Corian Grade A
Window Sills/Convactor	Solid Surface Painted Metal <u>Cost-saving Alternatives:</u> - Solid Surface, Corian Grade A - Plastic Laminate
Window Treatments	Shade Cloth, 3% opening and Shade Cloth, blackout Use double roller <u>Cost-saving Alternatives:</u> - Shade Cloth, 1% opening
<p>1. Provide coat hooks. Refer to Building Accessories subsection of these Design Guidelines.</p> <p>2. Turn the countertop material 4" up the back and side walls.</p>	

J4. WELLNESS / QUIET ROOM	
Item	Finish
Flooring	Resilient, tile Resilient, plank Carpet, tile
Base	Rubber, millwork Rubber, straight <u>Cost-saving Alternatives:</u> - Rubber, cove
Wall Finish	GWB (level 4 finish), paint (eggshell finish) Wall Covering (level 5 finish)
Door type/finish	HM, paint (semi-gloss finish), 8'-0" high Wood, 8'-0" high <u>Cost-saving Alternatives:</u> - HM, paint (semi-gloss finish), 7'-0" high - Wood, 7'-0" high
Door Frame type/finish	HM, paint (semi-gloss finish) <u>Cost-saving Alternatives:</u> - HM, paint (semi-gloss finish), knockdown w/ bondo joints
Ceiling Material	Lay-in, ACT, Hzone
Window Sills/Convactor	Solid Surface Painted Metal <u>Cost-saving Alternatives:</u> - Solid Surface, Corian Grade A - Plastic Laminate
Window Treatments	Shade Cloth, 3% opening and Shade Cloth, blackout Use double roller <u>Cost-saving Alternatives:</u> - Shade Cloth, 1% opening

K. TOILET ROOMS

K1. PUBLIC / STAFF TOILET / PATIENT TOILET (OUTPATIENT FACILITIES)	
Item	Finish
Flooring ¹	Porcelain, tile
Base	Porcelain, straight
Wall Finish	Porcelain, tile (level 2 finish) Wall Covering (level 5 finish; non-wet walls) <u>Cost-saving Alternatives:</u> - GWB (level 4 finish), paint, scrub-resistant (eggshell finish; non-wet walls)
Door type/finish ²	HM, paint (semi-gloss finish), 8'-0" high Wood, 8'-0" high <u>Cost-saving Alternatives:</u> - HM, paint (semi-gloss finish), 7'-0" high - Wood, 7'-0" high
Door Frame type/finish	HM, paint (semi-gloss finish) <u>Cost-saving Alternatives:</u> - HM, paint (semi-gloss finish), knockdown w/ bondo joints
Ceiling Material	GWB, paint (flat finish) Lay-in, ACT, Ultima
Countertops ³	Solid Surface Engineered Stone All-in-One Sink Assembly ⁴ <u>Cost-saving Alternatives:</u> - Solid Surface, Corian Grade A
Window Sills/Convactor	Solid Surface Painted Metal <u>Cost-saving Alternatives:</u> - Solid Surface, Corian Grade A
<ol style="list-style-type: none"> 1. Provide waterproofing under floor tile and turned up 8" along the perimeter when restrooms are located above critical patient areas (i.e. OR's, MRI's, Patient Rooms, Exam Rooms, etc.), IT spaces, Auditoriums and any other spaces designated by RED+F. 2. Provide coat hooks. Refer to Building Accessories subsection of these Design Guidelines. 3. Turn the countertop material 4" up the back and side walls, except where the All-in-One Sink Assembly is used. 4. Refer to Plumbing Fixtures subsection of these Design Guidelines for further information. 	

K2. PATIENT TOILET / SHOWER (INPATIENT FACILITIES)	
Item	Finish
Flooring ¹	Porcelain, tile (2x2 mosaic at shower floors)
Base	Porcelain, straight Porcelain, integral to match floor (at shower floors)
Wall Finish	Porcelain, tile (level 2 finish) Ceramic, tile (level 2 finish) Wall Covering (level 5 finish; non-wet walls) <u>Cost-saving Alternatives:</u> - Ceramic, tile (level 2 finish), Dal-tile (Modern Dimensions) - GWB (level 4 finish), paint, scrub-resistant (eggshell finish; non-wet walls)
Door type/finish ²	Wood, 8'-0" high <u>Cost-saving Alternatives:</u> - HM, paint (semi-gloss finish), 8'-0" high
Door Frame type/finish	HM, paint (semi-gloss finish)
Door Protection	Kickplate, Stainless Steel
Ceiling Material	GWB, paint (flat finish) Lay-in, ACT Hzone
Countertops ³	Solid Surface Engineered Stone <u>Cost-saving Alternatives:</u> - Solid Surface, Corian Grade A
Window Sills/Convactor	Solid Surface Painted Metal <u>Cost-saving Alternatives:</u> - Solid Surface, Corian Grade A
Shower Curtains	100% trevira, no mesh
<ol style="list-style-type: none"> 1. Provide waterproofing under floor tile and turned up 8" along the perimeter when restrooms are located above critical patient areas (i.e. OR's, MRI's, Patient Rooms, Exam Rooms, etc.), IT spaces, Auditoriums and any other spaces designated by RED+F. 2. Provide coat hooks. Refer to Building Accessories subsection of these Design Guidelines. 3. Turn the countertop material 4" up the back and side walls. 	

L. SUPPORT SPACES

L1. CLEAN UTILITY	
Item	Finish
Flooring	Rubber, sheet, chemically welded Rubber, tile, chemically welded Resilient, sheet, welded <u>Cost-saving Alternatives:</u> - Resilient, sheet, Gerflor (Mipolam Symbioz)
Base	Integral, sanitary cove base
Wall Finish	GWB (level 3 finish), paint, scrub-resistant (eggshell finish)
Door type/finish	HM, paint (semi-gloss finish), 8'-0" high <u>Cost-saving Alternatives:</u> - HM, paint (semi-gloss finish), 7'-0" high (Outpatient Facilities) - Wood, 7'-0" high (Outpatient Facilities)
Door Frame type/finish	HM, paint (semi-gloss finish) <u>Cost-saving Alternatives:</u> - HM, paint (semi-gloss finish), knockdown w/ bondo joints (Outpatient Facilities)
Door Protection	Kickplate, Stainless Steel
Ceiling Material ¹	Lay-in, ACT Clean Room VL
Millwork	Plastic Laminate Stainless Steel (Inpatient Facilities) Metal/Wire Shelving ² (Outpatient Facilities)
Countertops ³	Solid Surface, Corian Stainless Steel (Inpatient Facilities) <u>Cost-saving Alternatives:</u> - Solid Surface, Corian Grade A (Outpatient Facilities)
<ol style="list-style-type: none"> 1. Refer to item #4 in the Miscellaneous subsection of these Design Guidelines for further information. 2. Bottom shelf must be solid metal. 3. Turn the countertop material 4" up the back and side walls. 	

L2. SOILED UTILITY	
Item	Finish
Flooring	Rubber, sheet, chemically welded Rubber, tile, chemically welded Resilient, sheet, welded <u>Cost-saving Alternatives:</u> - Resilient, sheet, Gerflor (Mipolam Symbioz)
Base	Integral, sanitary cove base
Wall Finish	Impact Resistant GWB (level 3 finish), paint, scrub-resistant (eggshell finish; on upper portion)
Wall Protection	Impact Resistant Wall Covering, Inpro (Ricochet; on lower portion) <u>Cost-saving Alternatives:</u> - None (Outpatient Facilities)
Door type/finish	HM, paint (semi-gloss finish), 8'-0" high <u>Cost-saving Alternatives:</u> - HM, paint (semi-gloss finish), 7'-0" high (Outpatient Facilities) - Wood, 7'-0" high (Outpatient Facilities)
Door Frame type/finish	HM, paint (semi-gloss finish) <u>Cost-saving Alternatives:</u> - HM, paint (semi-gloss finish), knockdown w/ bondo joints (Outpatient Facilities)
Door Protection	Kickplate, Stainless Steel
Ceiling Material ¹	Lay-in, ACT Clean Room VL <u>Cost-saving Alternatives:</u> - GWB, paint (flat finish) (Outpatient Facilities)
Millwork	Stainless Steel
Countertops ²	Stainless Steel
<p>1. Refer to item #4 in the Miscellaneous subsection of these Design Guidelines for further information.</p> <p>2. Turn the countertop material 4" up the back and side walls.</p>	

L3. STORAGE ROOM	
Item	Finish
Flooring	Rubber, tile Resilient, tile
Base	Rubber, cove
Wall Finish	GWB (level 3 finish), paint (eggshell finish)
Door type/finish	HM, paint (semi-gloss finish), 8'-0" high <u>Cost-saving Alternatives:</u> - HM, paint (semi-gloss finish), 7'-0" high (Outpatient Facilities)
Door Frame type/finish	HM, paint (semi-gloss finish) <u>Cost-saving Alternatives:</u> - HM, paint (semi-gloss finish), knockdown w/ bondo joints (Outpatient Facilities)
Door Protection	Kickplate, Stainless Steel
Ceiling Material	Lay-in, ACT Hzone <u>Cost-saving Alternatives:</u> - Lay-in, ACT Ultima (Outpatient Facilities)
Millwork	Metal/Wire Shelving ¹ (Outpatient Facilities)
1. Bottom shelf must be solid metal.	

L4. JANITOR'S CLOSET	
Item	Finish
Flooring	Porcelain, tile (2x2 mosaic) <u>Cost-saving Alternatives:</u> - Rubber, sheet
Base	Integral, sanitary cove base <u>Cost-saving Alternatives:</u> - Rubber, cove
Wall Finish	GWB (level 3 finish), paint, scrub-resistant (eggshell finish; on upper portion) Ceramic, tile (level 2 finish) (min. 48" high on lower portion) <u>Cost-saving Alternatives:</u> - GWB (level 3 finish), paint (semi-gloss finish)
Door type/finish ³	HM, paint (semi-gloss finish), 8'-0" high <u>Cost-saving Alternatives:</u> - HM, paint (semi-gloss finish), 7'-0" high
Door Frame type/finish	HM, paint (semi-gloss finish) <u>Cost-saving Alternatives:</u> - HM, paint (semi-gloss finish), knockdown w/ bondo joints
Ceiling Material	Lay-in, ACT, Hzone (Washable)
Millwork	Metal/Wire Shelving ²
<ol style="list-style-type: none"> 1. Provide waterproofing under flooring and floor/scrub sinks. Turn it up 8" along the perimeter when Janitor's Closets are located above critical areas (i.e. IT spaces, Auditoriums, etc.) and any other spaces designated by RED+F. 2. Bottom shelf must be solid metal. Overall shelf dimensions to comply with code requirements. 3. Doors to swing out 180-degrees, if possible. 	

L5. SHOP	
Item	Finish
Flooring	Resilient, tile
Base	Rubber, cove
Wall Finish	GWB (level 3 finish), paint, scrub-resistant (eggshell finish) <u>Cost-saving Alternatives:</u> - GWB (level 3 finish), paint (semi-gloss finish)
Door type/finish	HM, paint (semi-gloss finish), 8'-0" high <u>Cost-saving Alternatives:</u> - HM, paint (semi-gloss finish), 7'-0"
Door Frame type/finish	HM, paint (semi-gloss finish) <u>Cost-saving Alternatives:</u> - HM, paint (semi-gloss finish), knockdown w/ bondo joints
Door Protection	Kickplate, Stainless Steel
Ceiling Material	Lay-in, ACT, Ultima

L6. BDF/IDF ROOM & DATA CENTER	
Item	Finish
Flooring	Static Dissipative Tile, match adj. flooring when possible
Base	Rubber, cove
Wall Finish	GWB (level 3 finish), scrub-resistant paint (eggshell finish) <u>Cost-saving Alternatives:</u> - GWB (level 3 finish), paint (semi-gloss finish)
Door type/finish	HM, paint (semi-gloss finish), 8'-0" high <u>Cost-saving Alternatives:</u> - HM, paint (semi-gloss finish), 7'-0" high
Door Frame type/finish	HM, paint (semi-gloss finish) <u>Cost-saving Alternatives:</u> - HM, paint (semi-gloss finish), knockdown w/ bondo joints
Ceiling Material	Exposed, paint (flat finish)

L7. MECHANICAL EQUIPMENT ROOM	
Item	Finish
Flooring	Concrete Coating, waterproofing (grey color)
Concrete Pads	Concrete Coating, waterproofing (yellow color)
Floor Drains	Painted, (yellow color)
Base	Waterproofing turned up 8"
Wall Finish	CMU, paint (eggshell finish) GWB (level 3 finish), paint, scrub-resistant (eggshell finish) <u>Cost-saving Alternatives:</u> - GWB (level 3 finish), paint (semi-gloss finish)
Door type/finish	HM (solid core) paint (semi-gloss finish)
Door Frame type/finish	HM (welded frame), paint (semi-gloss finish)
Ceiling Material	Exposed, paint (flat finish)

L8. ELECTRICAL EQUIPMENT ROOM	
Item	Finish
Flooring	Concrete coating, Fluid-Applied (red color)
Concrete Pads	Concrete coating, Fluid-Applied (yellow color)
Base	Rubber, cove, 6"
Wall Finish	GWB (level 3 finish), paint, scrub-resistant (eggshell finish) <u>Cost-saving Alternatives:</u> - GWB (level 3 finish), paint (semi-gloss finish)
Door type/finish	HM (solid core) paint (semi-gloss finish)
Door Frame type/finish	HM (welded frame), paint (semi-gloss finish)
Ceiling Material	Exposed, paint (flat finish) GWB, paint (flat finish)

MATERIAL LEGEND

In accordance with both our Mission devoted to excellence in patient care, education, and research and our Design Principles of providing timeless designs that are cost effective, efficient, functional and practical, RED+F has developed a palette of typical materials and finishes that we have found to be successful for various spaces at NYU Langone Health.

Our goals in listing these materials and finishes are to:

- Streamline the design process
- Assist the Architect and Interior Designer with specifying materials
- Comply with the Practice Greenhealth Healthcare Without Harm: Safer Chemicals Challenge, eliminating the use of formaldehyde, perfluorinated compounds, polyvinyl chloride (PVC), antimicrobials, and all flame retardants from all materials and finishes
- Create spaces that are timeless, durable, easily maintainable and cost-effective
- Create a consistent NYU Langone brand

The Architect and Interior Designer should use this as a guide for specifying the finishes on NYU Langone capital projects. This information does not relieve the Architect or Interior Designer of specifying materials that are appropriate and code compliant for specific spaces. The Architect and Interior Designer shall consider specifying existing building-specific standards provided they are in line with these Design Guidelines. Also, the Architect and Interior Designer may suggest other materials and finishes if they believe those proposed materials and finishes will support our mission, design principles, and the design intent of the project.

Recommended manufacturers and products for specific applications have been provided in the following categories:

- A. Flooring
- B. Base
- C. Wall Finish
- D. Doors and Door Frames
- E. Ceilings
- F. Millwork and Countertops
- G. Window Sills
- H. Window Treatments
- I. Shower Curtains
- J. Cubicle Curtains
- K. Cubicle Track

Use of materials in *Clinical* versus *Non-Clinical* spaces is denoted with an * located in both or one of the two columns to the right of the page.

A. FLOORING

Resilient Flooring						
	Manuf.	Model / Series	Color / Finish	Remarks	Clinical	Non-Clinical
Tile	American Biltrite	Texas Granite (SVT)	Varies (See manuf. info)	3.17mm, sizes vary; Phthalate-free; limited color options coordinate with American Biltrite Electrotile static dissipative tile	*	*
	Bentley Mills	Batiste (LVT)	Varies (See manuf. info)	5mm x 18" x 36"	*	*
	Gerflor	Saga ² (LVT)	Varies (See manuf. info)	4.6mm x 19.685" x 19.685"; Phthalate-free	*	*
	Gerflor	Creation (LVT)	Varies (See manuf. info)	sizes vary; Phthalate-free	*	*
	Patcraft	Admix	Varies (See manuf. info)	3.2mm, sizes vary; PVC-free; terrazzo look; can be heat welded and flash covered	*	*
	Patcraft	Admix Encore	Varies (See manuf. info)	3.2mm x 12" x 12"; PVC-free; can be heat welded and flash covered	*	*
	Patcraft	Meaning Tile	Varies (See manuf. info)	2.5mm x 13.19" x 26.38"; PVC-free	*	*
	Patcraft	Aggregate (LVT)	Varies (See manuf. info)	2.5mm x 24" x 24";	*	*
	Shaw Contract	Amalgam (LVT)	Varies (See manuf. info)	5mm x 20" x 20"	*	*
	Shaw Contract	Cast 2.5 (LVT)	Varies (See manuf. info)	2.5mm x 24" x 24"	*	*
	Shaw Contract	Compound 2.5 (LVT)	Varies (See manuf. info)	2.5mm x 24" x 24"	*	*
	Shaw Contract	Eon (LVT)	Varies (See manuf. info)	5mm x 20" x 20"	*	*
	Shaw Contract	Innate	Varies (See manuf. info)	2.5mm x 13" x 26"	*	*
	Shaw Contract	Intricate (LVT)	Varies (See manuf. info)	2.5mm x 12" x 24"	*	*
	Shaw Contract	Kind (LVT)	Varies (See manuf. info)	5mm x 24" x 24"	*	*
	Shaw Contract	Terrace 2.5 (LVT)	Varies (See manuf. info)	2.5mm x 12" x 24"	*	*
	Shaw Contract	Thoughtful (LVT)	Varies (See manuf. info)	5mm x 24" x 24"	*	*
	Upofloor	Zero	Varies (See manuf. info)	2mm x 20" x 20"; PVC-free	*	*

	Manuf.	Model / Series	Color / Finish	Remarks	Clinical	Non-Clinical
Wood Plank	Gerflor	Creation	Varies (See manuf. info)	sizes vary; Phthalate-free	*	*
	Shaw Contract	Cover (SPC)	Varies (See manuf. info)	4mm x 7" x 48"	*	*
	Shaw Contract	Envelop (SPC)	Varies (See manuf. info)	4mm x 7" x 48"	*	*
	Upofloor	Xpressions Small Planks	Varies (See manuf. info)	2mm. x 4" x 36"; PVC-free	*	*
	Notes: 1. All wood planks are to be non-beveled.					
	Manuf.	Model / Series	Color / Finish	Remarks	Clinical	Non-Clinical
Floating Floor	Gerflor	Creation (LVT)	Varies (See manuf. info)	sizes vary; Phthalate-free	*	*
	Notes: 1. Confirm project specific rolling load requirement for appropriate material selection. 2. Confirm project specific acoustic and moisture mitigation requirements for appropriate material selection.					
	Manuf.	Model / Series	Color / Finish	Remarks	Clinical	Non-Clinical
Sheet	Gerflor	Mipolam Symbioz	Varies (See manuf. info)	2mm. x 6'-6"; Phthalate-free	*	
	Patcraft	Ivy Walk	Varies (See manuf. info)	2.2mm x 72"	*	
	Upofloor	Zero	Varies (See manuf. info)	2mm. x 4'-9"; PVC-free	*	
	Manuf.	Model / Series	Color / Finish	Remarks	Clinical	Non-Clinical
Wood Sheet	Polyflor	Forest FX PUR	Varies (See manuf. info)	2mm. x 2m.; Phthalate-free	*	
	Patcraft	Enrich Sheet	Varies (See manuf. info)	2.5mm. x 6.59'; PVC-free	*	*
	Manuf.	Model / Series	Color / Finish	Remarks	Clinical	Non-Clinical
Specialty Sheet	Altro	Walkway 20	Varies (See manuf. info)	2mm. x 6'-7"; slip-resistant; Phthalate-free; avail. in static dissipative version	*	*
	Polyflor	Polysafe Verona PUR	Varies (See manuf. info)	2mm. x 2m.; slip-resistant; Phthalate-free	*	*

Rubber Flooring						
	Manuf.	Model / Series	Color / Finish	Remarks	Clinical	Non-Clinical
Tile	Nora by Interface	Norament Grano	Varies (See manuf. info)	3.5mm. x 40" x 40"	*	*
	Nora by Interface	Norament Pado	Varies (See manuf. info)	3.5mm x 40" x 40"	*	*
	Nora by Interface	Norament Satura	Varies (See manuf. info)	3.5mm. x 40" x 40"	*	*
	Nora by Interface	Norament XP	Varies (See manuf. info)	3.5mm. x 40" x 40" (for Sterile Zone in OR and procedure rooms w/ ESD requirements)	*	
	Manuf.	Model / Series	Color / Finish	Remarks	Clinical	Non-Clinical
Sheet	Nora by Interface	Valua	Varies (See manuf. info)	2mm. or 3mm. x 48"w	*	

Linoleum						
	Manuf.	Model / Series	Color / Finish	Remarks	Clinical	Non-Clinical
Tile	Forbo	MCT Modular Tile	Varies (See manuf. info)	2.0mm x 13.11" x 13.11"	*	*
	Manuf.	Model / Series	Color / Finish	Remarks	Clinical	Non-Clinical
Sheet	Gerflor	Landscape	Varies (See manuf. info)		*	*

Static Dissipative						
	Manuf.	Model / Series	Color / Finish	Remarks	Clinical	Non-Clinical
Resilient	American Biltrite	Electrotile	Varies (See manuf. info)	3.17mm, sizes vary; PVC-free; limited color options coordinate with American Biltrite Texas Granite SVT	*	*
Notes:						
1. For BDF / IDF Rooms and Data Centers use Static Dissipative Tile (SDT) installed as a system per manufacturer’s complete specification. Refer to the Information Technology subsection of these Design Guidelines for additional information.						

Wood						
	Manuf.	Model / Series	Color / Finish	Remarks	Clinical	Non-Clinical
	Varies	Varies	Varies (See manuf. info)		*	*

Sports						
	Manuf.	Model / Series	Color / Finish	Remarks	Clinical	Non-Clinical
	Gerflor	<u>Taraflex Sport M Plus</u>	Varies (See manuf. info)		*	*

Carpet						
	Manuf.	Model / Series	Color / Finish	Remarks	Clinical	Non-Clinical
	Bentley Mills	Varies (See manuf. info)	Varies (See manuf. info)			*
	Interface	Varies (See manuf. info)	Varies (See manuf. info)			*
	Mohawk	Varies (See manuf. info)	Varies (See manuf. info)			*
	Patcraft	Varies (See manuf. info)	Varies (See manuf. info)			*
	Shaw	Varies (See manuf. info)	Varies (See manuf. info)			*
	Tandus Centiva	Varies (See manuf. info)	Varies (See manuf. info)			*

Walk-Off Carpet						
	Manuf.	Model / Series	Color / Finish	Remarks	Clinical	Non-Clinical
	Mats Inc.	Decorib	Charcoal	High-density rubber back runner		*
	Patcraft	Walk Forward (modular)	Varies (See manuf. info)	24" x 24" tile; PVC-free		*
	Tarkett	Abrasive Action II (modular)	Varies (See manuf. info)	24" x 24" tile; PVC-free; provide w/ Powerbond Cushion backing		*
	Tarkett	Assertive Action (modular)	Varies (See manuf. info)	24" x 24" tile; PVC-free; provide w/ Powerbond Cushion backing		*
	Tarkett	Assertive Stria (modular)	Varies (See manuf. info)	24" x 24" tile; PVC-free; provide w/ Powerbond Cushion backing		*
	Tarkett	Assertive Rib (modular)	Varies (See manuf. info)	24" x 24" tile; PVC-free; provide w/ Powerbond Cushion backing		*
Notes:						
1. Provide 15-foot min. depth of walk-off carpeting from the building entry to specified hard flooring within the building.						

Porcelain Tile						
	Manuf.	Model / Series	Color / Finish	Remarks	Clinical	Non-Clinical
	Crossville	Varies	Varies (See manuf. info)	available in 2" x 2" mosaic (Java Joint series)	*	*
	Dal-Tile	Keystones Colorbody Porcelain	Varies (See manuf. info)	2" x 2" mosaic	*	*
	Dal-Tile	Varies	Varies (See manuf. info)		*	*
	Mosa	Varies	Varies (See manuf. info)		*	*
	Stone Source	Varies	Varies (See manuf. info)		*	*

Notes:

1. Confirm use of products on walls with RED+F and floor tile manufacturer.
2. Grout shall be cleanable and of a darker color.
3. To clean and restore existing tile, use tile and grout cleaning and preservation services such as those provided by RD Weis. Do not apply any material over existing tile as a means to refresh its appearance.

Quarry Tile						
	Manuf.	Model / Series	Color / Finish	Remarks	Clinical	Non-Clinical
	Dal-Tile	Quarry Tile	Varies (See manuf. info)	½" x 6" x 6"	*	*

Notes:

1. Grout shall be cleanable and of a darker color.
2. To clean and restore existing tile, use tile and grout cleaning and preservation services such as those provided by RD Weis. Do not apply any material over existing tile as a means to refresh its appearance.

Stone Tile						
	Manuf.	Model / Series	Color / Finish	Remarks	Clinical	Non-Clinical
	Varies	Varies	Varies (See manuf. info)		*	*

Notes:

1. Grout shall be cleanable and of a darker color.
2. To clean and restore existing tile, use tile and grout cleaning and preservation services such as those provided by RD Weis. Do not apply any material over existing tile as a means to refresh its appearance.

Terrazzo						
	Manuf.	Model / Series	Color / Finish	Remarks	Clinical	Non-Clinical
Poured	Custom Mix		Varies	Thin set epoxy with zinc dividers, ¼", 3/8", ½" thick	*	*
	Port Morris Tile and Marble (or approved equal)		Varies	Thin set epoxy with zinc dividers, 3/8" T	*	*

Concrete Coatings						
	Manuf.	Model / Series	Color / Finish	Remarks	Clinical	Non-Clinical
Water-proofing	Kemper Systems	Kemperol 2K-PUR		At Mech Rooms – Provide 20-year warranty		*
	Manuf.	Model / Series	Color / Finish	Remarks	Clinical	Non-Clinical
Fluid-Applied	Lifetime Green Coatings	Ecodur	Varies (See manuf. info)	Non-toxic, VOC and BPA free, Class A fire rating		*

B. BASE

Rubber Base						
	Manuf.	Model / Series	Color / Finish	Remarks	Clinical	Non-Clinical
Cove	Johnsonite	Baseworks	Varies (See manuf. info)	1/8" x 4" or 6"	*	*
	Johnsonite	Baseworks	Varies (See manuf. info)	1/8" x 4" or 6"	*	*
Millwork	Johnsonite	Mandalay	#69 Sterling Silver / Metallic	3/8" x 4-1/2" or 6"; use with 3/4" round when necessary	*	*
	Johnsonite	Mandalay	#69 Sterling Silver / Metallic	3/8" x 4-1/2" or 6"; use with 3/4" round when necessary	*	*

Notes:

1. Comparable Roppe products are acceptable.
2. Coordinate height of adjacent millwork/casework with finished base height.
3. 4" and 6" base heights must be maintained. 6" base height is required at inpatient locations.

Integral Base						
	Manuf.	Model / Series	Color / Finish	Remarks	Clinical	Non-Clinical
Integral Cove	Varies	Varies	Varies (See manuf. info)	Cove to match floor material, seamless, 6"H	*	*
	Flexco Floors	Health Design	Varies (See manuf. info)	Sanitary cove base for use with vinyl flooring, seamless, 6"H, coordinate thickness with adjacent floor	*	*
Sanitary Cove	Nora	Sanitary Base	Varies (See manuf. info)	Sanitary cove base for use with Nora rubber flooring; seamless, 6" H, coordinate thickness with adjacent sheet floor	*	*
	Flexco Floors	Health Design	Varies (See manuf. info)	Sanitary cove base for use with vinyl flooring, seamless, 6"H, coordinate thickness with adjacent floor	*	*

Notes:

1. Provide Burke Mercer #075-400 semi-rigid cove stick at integral cove base to prevent denting and puncture.

Stainless Steel Base						
	Manuf.	Model / Series	Color / Finish	Remarks	Clinical	Non-Clinical
	Custom	Custom	Non-directional Stainless Steel	18 Ga, height varies	*	*

Aluminum Base						
	Manuf.	Model / Series	Color / Finish	Remarks	Clinical	Non-Clinical
	AlumaFloor	Alloy 5052	Clear anodized with matte finish	0.040" thick, 6" high	*	*

Porcelain Base						
	Manuf.	Model / Series	Color / Finish	Remarks	Clinical	Non-Clinical
	Varies	Varies	Varies (See manuf. info)	Cove, to match floor or wall tile	*	*
Notes: 1. When floor tile does not have a matching base, cut floor tile to specified height and use Schluter trim at exposed / cut edge.						

Quarry Base						
	Manuf.	Model / Series	Color / Finish	Remarks	Clinical	Non-Clinical
	Varies	Varies	Varies (See manuf. info)	Cove, to match floor tile		*
Notes: 1. When floor tile does not have a matching base, cut floor tile to specified height and use Schluter trim at exposed / cut edge.						

Stone Base						
	Manuf.	Model / Series	Color / Finish	Remarks	Clinical	Non-Clinical
	Varies	Varies	Varies (See manuf. info)	To match adjacent floor material		*
Notes: 1. When floor tile does not have a matching base, cut floor tile to specified height and use Schluter trim at exposed / cut edge.						

Wood Base						
	Manuf.	Model / Series	Color / Finish	Remarks	Clinical	Non-Clinical
	Varies	Varies	Varies (See manuf. info)			*

Transitions / Trim						
	Manuf.	Model / Series	Color / Finish	Remarks	Clinical	Non-Clinical
	Johnsonite	Varies	Varies (See manuf. info)		*	*
	Schluter	Varies	Varies (See manuf. info)		*	*
	Tandus Centiva	Metal Edge	Varies (See manuf. info)		*	*

C. WALL FINISH

1. Gypsum board shall extend to the underside of slab, unless noted otherwise.
2. Gypsum board finish levels shall be as follows and according to applicable codes and standards, unless noted otherwise:
 - Level 1 finish shall be applied at ceiling plenums and concealed areas unless a higher level of finish is required for fire-resistance-rated and/or sound-related assemblies. The tape at the joints shall be embedded.
 - Level 2 finish shall be applied to water-resistant gypsum board, where panels are substrate for tile (i.e. Patient Toilets/Showers, Public/Staff Toilets, Pantries, Cafeterias, and similar spaces). The tape at the joints shall be embedded and a separate first coat of joint compound shall be applied to the tape, fasteners, and trim flanges.
 - Level 3 finish shall be applied to panels in back-of-house/support spaces (i.e. Clean/Soiled Utility, Storage Rooms, Janitor's Closets, Shops, BDF / IDF Rooms, Data Centers, Mechanical Equipment Rooms, Electrical Equipment Rooms, and similar spaces). The tape at the joints shall be embedded and a separate first and fill coat of joint compound shall be applied to the tape, fasteners and trim flanges. Joint compound shall be smooth and free from tool marks and ridges.
 - Level 4 finish shall be applied to panels in non-public spaces (i.e. Private Offices, Open Work Areas, Staff Lounges/Locker Rooms, Pantries/Food Preparation Areas, Lactation/Wellness Rooms, Patient Rooms, Nurse/Medical Assistant Stations, Changing Rooms, Gown Waiting, Exam/Procedure Rooms, Phlebotomy Labs/Blood Draw, Laboratories, Vivariums, Toilets/Showers, Corridors, and similar spaces). The tape at the joints shall be embedded and a separate first, fill, and finish coat of joint compound shall be applied to the tape, fasteners, and trim flanges.
 - Level 5 finish shall be applied to panels in public spaces (i.e. Entry Vestibules, Public Lobbies, Reception/Waiting Areas, Family Lounges, Auditoriums, Lecture Halls, Seminar Rooms, Conference/Training Rooms, Public Cafeterias, Public Corridors and similar spaces), at walls to receive wall coverings, and areas scheduled to received accent lighting or semi-gloss finishes. The tape at the joints shall be embedded and a separate first, fill and finish coat of joint compound shall be applied to the tape, fasteners and trim flanges. A skim coat of joint compound shall be applied over the entire surface.

GWB / Paint						
	Manuf.	Model / Series	Color / Finish	Remarks	Clinical	Non-Clinical
Standard	Benjamin Moore	EcoSpec Interior Latex	Finish as scheduled (Flat, eggshell and semi-gloss)	Use with Ultra Spec 500 Interior Latex Primer (N534)	*	*
Scrub-resistant	Benjamin Moore	Ultra Spec SCUFF-X	Eggshell Finish	Use with Ultra Spec 500 Interior Latex Primer (N534)	*	*
	Scuffmaster	Scrubtough	Eggshell Finish		*	*

Wall Covering						
	Manuf.	Model / Series	Color / Finish	Remarks	Clinical	Non-Clinical
	Arc Com	PVC-free	Varies (See manuf. info)	With breathable back; gyp. board finish level 5	*	*
	Carnegie	Type II / PVC-Free TPO	Varies (See manuf. info)	With breathable back; gyp. board finish level 5	*	*
	Carnegie	Xorel	Varies (See manuf. info)	With breathable back; gyp. board finish level 5	*	*
	Design Tex	PVC-free	Varies (See manuf. info)	With breathable back; gyp. board finish level 5	*	*
	Innovations	PVC-free	Varies (See manuf. info)	With breathable back; gyp. board finish level 5	*	*
	Knoll	PVC-free	Varies (See manuf. info)	With breathable back; gyp. board finish level 5	*	*
	Maharam	PVC-free	Varies (See manuf. info)	With breathable back; gyp. board finish level 5	*	*
<p>Notes:</p> <ol style="list-style-type: none"> 1. Installer shall be trained / certified by manufacturer. 2. Install per manufacturer’s instructions. (i.e. appropriate wall preparation, primers, adhesives, methods, etc.) 3. Contractor to use a sharp blade when cutting material. 4. Provide appropriate finish detailing at inner and outer corners, ceiling and base to prevent fraying and delamination. 5. Provide 15% attic stock. 						

Acoustic Solutions						
	Manuf.	Model / Series	Color / Finish	Remarks	Clinical	Non-Clinical
	Buzzispace	Felt	Varies (See manuf. info)	3mm., direct glue and panels		*
	Carnegie	Varies	Varies (See manuf. info)			*
	Design Tex	Felt AM002	Varies (See manuf. info)	3mm., direct glue		*
	Fitzfelt	Felt	Varies (See manuf. info)	3mm., direct glue		*
	Snowsound	Fiber Acoustic Textiles	Varies (See manuf. info)			*
<p>Notes:</p> <ol style="list-style-type: none"> 1. Wall covering panels in conference rooms shall have a full panel centered on the conference room table. 						

Ceramic Tile						
	Manuf.	Model / Series	Color / Finish	Remarks	Clinical	Non-Clinical
	Crossville	Varies	Varies (See manuf. info)		*	*
	Dal-Tile	Varies	Varies (See manuf. info)		*	*
	Mosa	Varies	Varies (See manuf. info)		*	*

Notes:

1. Grout shall be cleanable and of a darker color.
2. To clean and restore existing tile, use tile and grout cleaning and preservation services such as those provided by RD Weis. Do not apply any material over existing tile as a means to refresh its appearance.

Glass Tile						
	Manuf.	Model / Series	Color / Finish	Remarks	Clinical	Non-Clinical
	Crossville	Varies	Varies (See manuf. info)		*	*
	Creative Materials	Admired	Varies (See manuf. info)		*	*
	Dal-Tile	Color Wave	Varies (See manuf. info)	Accent Tile, sizes vary	*	*
	Nemo	Glass Hues	Varies (See manuf. info)	Accent Tile, sizes vary	*	*

Notes:

1. Grout shall be cleanable and of a darker color.
2. To clean and restore existing tile, use tile and grout cleaning and preservation services such as those provided by RD Weis. Do not apply any material over existing tile as a means to refresh its appearance.

Porcelain Tile						
	Manuf.	Model / Series	Color / Finish	Remarks	Clinical	Non-Clinical
	Crossville	Varies	Varies (See manuf. info)		*	*
	Dal-Tile	Varies	Varies (See manuf. info)		*	*
	Mosa	Varies	Varies (See manuf. info)		*	*
	Stone Source	Varies	Varies (See manuf. info)	confirm lead times	*	*

Notes:

1. If applicable, porcelain floor tile can run up wall. A/E Team to confirm use of floor tile products on walls with RED+F and floor tile manufacturer.
2. Grout shall be cleanable and of a darker color.
3. To clean and restore existing tile, use tile and grout cleaning and preservation services such as those provided by RD Weis. Do not apply any material over existing tile as a means to refresh its appearance.

Tile Trim						
	Manuf.	Model / Series	Color / Finish	Remarks	Clinical	Non-Clinical
	Schluter	Varies	Varies (See manuf. info)		*	*

Specialty Materials						
	Manuf.	Model / Series	Color / Finish	Remarks	Clinical	Non-Clinical
Wood	Architectural Systems	MDF Panels	Varies (See manuf. info)		*	*
	Robin Reigi	Plyboo Strand Plyboard			*	*
	Varies		Species varies; Clear Finish (See manuf. info)		*	*
	Manuf.	Model / Series	Color / Finish	Remarks	Clinical	Non-Clinical
Metal	C-S Group	Varies	Varies (See manuf. info)		*	*
	Forms + Surfaces	Varies	Varies (See manuf. info)		*	*
	Varies	Varies	Decorative metal mesh		*	*
	Varies	Varies	Stainless Steel		*	*
	Varies	Diamond Plate	Alum.		*	*
	Manuf.	Model / Series	Color / Finish	Remarks	Clinical	Non-Clinical
Stone	Varies	Varies	Varies (See manuf. info)		*	*
	Manuf.	Model / Series	Color / Finish	Remarks	Clinical	Non-Clinical
Porcelain Tile Panels	Crossville	Laminam	Varies (See manuf. info)	1mx 3m panel size; 3mm T (wall only applications); 5.6mm T (wall and floor applications)	*	*
	Manuf.	Model / Series	Color / Finish	Remarks	Clinical	Non-Clinical
Acrylic Resin	3-Form	Acrylic Resin, Varia Ecoresin			*	*
	3-Form	Acrylic Resin, Chroma			*	*
	Lightblocks	Acrylic Panels	Varies (See manuf. info)	Gauge varies, 1/16" – 2" panel thickness available; std. panel size 48" x 96"	*	*

	Manuf.	Model / Series	Color / Finish	Remarks	Clinical	Non-Clinical
Glass	Bendheim	Varies	Varies (See manuf. info)		*	*
	Custom	Varies	Varies (See manuf. info)	Back-painted glass	*	*
	Forms + Surfaces	Varies	Varies (See manuf. info)		*	*
	Forms + Surfaces	VividGlass / ViviGraphix	VIEW VGV26-97-A-3G3G	Behind Reception Desks	*	*
	Skyline Design	Varies	Varies (See manuf. info)		*	*
Notes: 1. All glass edges shall be water jet edge, especially for backlit glass behind the reception desk.						
	Manuf.	Model / Series	Color / Finish	Remarks	Clinical	Non-Clinical
Applied Film	DesignTex	3M DI-NOC	Varies (See manuf. info)	Installer must be certified by manufacturer; GWB wall finish level 5	*	*

Wall Protection						
	Manuf.	Model / Series	Color / Finish	Remarks	Clinical	Non-Clinical
Impact Resistant Wall Covering	Inpro	Ricochet	Varies (See manuf. info)	Impact Resistant; permitted on new construction projects only; must be installed by a wall covering professional	*	
	Notes: 1. Installer shall be trained / certified by manufacturer. 2. Install per manufacturer's instructions. (i.e. appropriate wall preparation, primers, adhesives, methods, etc.)					
	Manuf.	Model / Series	Color / Finish	Remarks	Clinical	Non-Clinical
Sheet	Corian	Varies	Varies (See manuf. info)	Solid Surface	*	
	Inpro	Endurant Bioprism	Varies (See manuf. info)	Solid Surface	*	
	Lumicor	Wall Protection Sheet	Varies (See manuf. info)		*	
	Manuf.	Model / Series	Color / Finish	Remarks	Clinical	Non-Clinical
Alum. Plate	Varies	Diamond Plate	Alum.		*	*

	Manuf.	Model / Series	Color / Finish	Remarks	Clinical	Non-Clinical
Corner Guards	C-S Group	Model CO-8	Stainless Steel	Full Height; 1" Leg Length at FGP and administrative sites; 2-1/2" Leg Length at all other clinical sites, unless noted otherwise	*	*
	C-S Group	Model SCO-8	Stainless Steel	Leg Length: 2-1/2" unless noted otherwise	*	
	Manuf.	Model / Series	Color / Finish	Remarks	Clinical	Non-Clinical
Rubstrip	C-S Group	Rub Strip, Acrovyn 4000 Series RS-60N	metal, brushed nickel	.060" thick x 9" H; use C-S Group water-based mastic adhesive; confirm spec w/ RED+F	*	
	Manuf.	Model / Series	Color / Finish	Remarks	Clinical	Non-Clinical
Crash Rails	C-S Group	Crash Rail, ECR 32S//60S	Stainless Steel	Concealed fasteners preferred. Coor'd bracket type, min. lengths and splice locations w/ Design Studio.	*	
	C-S Group	Crash Rail, SCR 16SSV			*	
	Manuf.	Model / Series	Color / Finish	Remarks	Clinical	Non-Clinical
Bumper Guard	C-S Group	Model HB-100D	Black EPDM rubber	With mechanical fasteners	*	
	Manuf.	Model / Series	Color / Finish	Remarks	Clinical	Non-Clinical
Handrails	C-S Group	Model P-RWS	Stainless Steel / Wood	Stainless Steel crash rail w/ wooden handrail	*	
	Inpro	Series 3500	Stainless Steel / Wood	Stainless Steel crash rail w/ wooden handrail	*	
	Manuf.	Model / Series	Color / Finish	Remarks	Clinical	Non-Clinical
Chair Rail	Johnsonite	Millwork Rampart	Varies (See manuf. info)	4"H x 3/8"	*	

Demountable Partitions (Private Offices / Conference Rooms Only)						
	Manuf.	Model / Series	Color / Finish	Remarks	Clinical	Non-Clinical
	AllSteel	Beyond (framed)	Varies (See manuf. info)		*	*
	Dirtt	Rectilinear Profile Stickbuilt	Varies (See manuf. info)		*	*
	KI	Lightline	Varies (See manuf. info)		*	*
	Steelcase	Everwall	Varies (See manuf. info)		*	*
	Steelcase	V.I.A.	Varies (See manuf. info)		*	*
	Teknion	Altos Portrait Optus	Varies (See manuf. info)		*	*
<p>1. Notes: Provide glass as follows:</p> <ul style="list-style-type: none"> a. For gradient glass, provide 100% opacity from 0' to 3' AFF. Opacity shall then transition from 100% at 3' AFF to 0% opacity at 7' AFF. b. For non-gradient translucent glass in clinical facilities match Dillmeier DG9-113. c. For non-gradient translucent glass in non-clinical facilities match ½" low iron acoustic 85% white laminate. <p>2. Demountable partition specification shall comply with the floor leveling conditions specified.</p>						

Glass Storefront						
	Manuf.	Model / Series	Color / Finish	Remarks	Clinical	Non-Clinical
	Varies	Varies	Varies (See manuf. info)			*

D. DOORS AND DOOR FRAMES

HM Doors and Frames / Paint						
	Manuf.	Model / Series	Color / Finish	Remarks	Clinical	Non-Clinical
Scrub-resistant	Benjamin Moore	Ultra Spec SCUFF-X	Semi-gloss finish	Use w/ Ultra Spec HP Acrylic Metal Primer (HP04)	*	*
	Scuffmaster	Scrubtough Max	Semi-gloss finish		*	*
Metallic	Scuffmaster	Solid Metal	Metallic finish	Elevator doors and frames	*	*

Wood Door						
	Manuf.	Model / Series	Color / Finish	Remarks	Clinical	Non-Clinical
	Varies		Species varies; (See manuf. info)	Clear Finish	*	*

Acrovyn Door						
	Manuf.	Model / Series	Color / Finish	Remarks	Clinical	Non-Clinical
	C-S Group		Faux wood / metal finish	Color TBD (Langone Orthopedic Hospital and Long Island Hospital only)	*	*

Glass Storefront Doors						
	Manuf.	Model / Series	Color / Finish	Remarks	Clinical	Non-Clinical
	Varies	Varies	Varies (See manuf. info)	Match finish of storefront assembly		*

Stainless Steel Doors and Frames						
	Manuf.	Model / Series	Color / Finish	Remarks	Clinical	Non-Clinical
	Varies	Varies	#4 finish			*
	Varies	Varies	Non-directional			*

Door Protection						
	Manuf.	Model / Series	Color / Finish	Remarks	Clinical	Non-Clinical
	C-S Group	Model KP-SS	#304 16ga. stainless steel	Kick plate; Coor'd height with door schedule	*	*
	Varies	Diamond Plate	Alum. Plate	Armor plate; Coor'd height with door schedule	*	*

E. CEILINGS

GWB / Paint						
	Manuf.	Model / Series	Color / Finish	Remarks	Clinical	Non-Clinical
Standard	Benjamin Moore	EcoSpec	Flat finish	Use with Ultra Spec 500 Interior Latex Primer (N534)	*	*
Scrub-resistant	Benjamin Moore	Ultra Spec SCUFF-X	Eggshell Finish	Use with Ultra Spec 500 Interior Latex Primer (N534)	*	*
	Scuffmaster	Scrubtough	Eggshell Finish		*	*

Lay-In Ceiling						
	Manuf.	Model / Series	Color / Finish	Remarks	Clinical	Non-Clinical
ACT	Armstrong	Ultima Health Zone #1936		9/16" beveled tegular, 3/4" x 24" x 24"	*	*
	Armstrong	Ultima Health Zone #1937		15/16" beveled tegular, 3/4" x 24" x 24" (outpatient facilities only)	*	*
	Armstrong	Ultima #1912		9/16" beveled tegular, 3/4" x 24" x 24"	*	*
	Armstrong	Ultima #1911		15/16" beveled tegular, 3/4" x 24" x 24"(outpatient facilities only)	*	*
	Armstrong	Clean Room VL #868		Unperforated, square lay-in, 5/8" x 24" x 24" w/ 15/16" Co-Extruded Clean Rm Grid	*	
Notes: 1. Avoid ceiling tile slivers less than 6" wide. Specify larger tile for wall locations where this may occur and cut the tile. For example, if 2'x2' ACT is specified and it results in slivers of less than 6" in some spaces, the A/E Team should consider specifying larger 2'x4' ACT for that wall location and cutting the larger tile down. Therefore, instead of a 2'-0" x 0'-6" sliver, you end up with 2'-0" x 2'-6" ACT tile.						
	Manuf.	Model / Series	Color / Finish	Remarks	Clinical	Non-Clinical
ACT Grid	Armstrong	Interlude XL HRC	White	9/16"	*	*
	Armstrong	Prelude XL HRC	White	15/16" (outpatient facilities only)	*	

Modular Ceiling Systems						
	Manuf.	Model / Series	Color / Finish	Remarks	Clinical	Non-Clinical
	BASX	Varies	Varies	Operating Rooms	*	
Notes:						
1. Modular OR ceilings shall be equipped with HEPA filtration.						

Specialty Material						
	Manuf.	Model / Series	Color / Finish	Remarks	Clinical	Non-Clinical
Wood	Armstrong	Woodworks	Varies (See manuf. info)	Linear, Grille or Vector	*	*
Metal	Lindner USA	LMD-E 200 Hook on System	Finish: custom makore; direct printed metal faux wood veneer; or white	Custom upturned panel lengths thru-out; 24 ga steel panel micro-perforated w/ RG 0, 7-4 w/ mineral wool lined 0.5" alum. honeycomb core; typ. panel size 2' x 3'; 1/8" black neoprene gasket joint on all sides	*	*
	Varies	Varies	Stl. Stl. / Match adj. wall panels		*	*
Fiberglass-Reinforced Panel	Arcoplast	Varies	Varies (See manuf. info)			*
Notes:						
1. Type of specialty acoustic material at ceilings to be confirmed by Architect and/or Acoustic Consultant.						
2. Ceilings shall be installed per manufacturer specifications unless noted otherwise.						
3. Removal of ceiling panels shall not require removal of adjacent panels.						

F. MILLWORK AND COUNTERTOPS

1. All millwork substrate shall be formaldehyde free.
2. Provide 4” or full height backsplash, typ.
3. Provide 4” sidesplash, where required.
4. High Pressure Laminate (HPL) shall be used for horizontal surfaces.

Plastic Laminate						
	Manuf.	Model / Series	Color / Finish	Remarks	Clinical	Non-Clinical
Wood Grain and Solid	Formica	Varies	Varies (See manuf. info)		*	*
	Nevamar	Varies	Varies (See manuf. info)		*	*
	Pionite	Varies	Varies (See manuf. info)		*	*
	Wilsonart	Varies	Varies (See manuf. info)		*	*

Solid Surface						
	Manuf.	Model / Series	Color / Finish	Remarks	Clinical	Non-Clinical
	Corian	Varies	Varies (See manuf. info)	Corian used as worksurface (i.e. at reception desks, workstations, nurse stations, etc.) shall be tested for mouse functionality.	*	*
	Formica	Varies	Varies (See manuf. info)		*	*
	Wilsonart	Varies	Varies (See manuf. info)		*	*

Engineered Stone						
	Manuf.	Model / Series	Color / Finish	Remarks	Clinical	Non-Clinical
	Caesarstone	Varies	Varies (See manuf. info)		*	*
	Dupont	Corian Quartz	Varies (See manuf. info)		*	*
	Cambria	Varies	Varies (See manuf. info)		*	*

Stone						
	Manuf.	Model / Series	Color / Finish	Remarks	Clinical	Non-Clinical
	Varies	Varies	Varies (See manuf. info)			*

Wood						
	Manuf.	Model / Series	Color / Finish	Remarks	Clinical	Non-Clinical
	Varies	Varies	Species Varies; Clear Finish (See manuf. info)	Provide protective glass, if required		*

Stainless Steel						
	Manuf.	Model / Series	Color / Finish	Remarks	Clinical	Non-Clinical
	Varies	Varies	#4 finish		*	*

Specialty Material						
	Manuf.	Model / Series	Color / Finish	Remarks	Clinical	Non-Clinical
Acrylic	3-Form	Acrylic Resin, Varia Ecoresin			*	*
	3-Form	Acrylic Resin, Chroma			*	*
	Lightblocks	Acrylic Panels	Varies (See manuf. info)	Gauge varies, 1/16" – 2" panel thickness available; standard panel size 48"x 96"	*	*
	Lumicor	Varies	Varies (See manuf. info)		*	*
Phenolic Resin	Manuf.	Model / Series	Color / Finish	Remarks	Clinical	Non-Clinical
	Varies	Varies	Varies (See manuf. info)	Countertops in Laboratories Only	*	*
Misc.	Manuf.	Model / Series	Color / Finish	Remarks	Clinical	Non-Clinical
	Architectural Systems	Varies	Varies (See manuf. info)	Not for use at countertops	*	*
Decorative Glass	Manuf.	Model / Series	Color / Finish	Remarks	Clinical	Non-Clinical
	Bendheim	Varies	Varies (See manuf. info)	Not for use at countertops	*	
	Forms + Surfaces	Varies	Varies (See manuf. info)	Not for use at countertops	*	
	Skyline Design	Varies	Varies (See manuf. info)	Not for use at countertops	*	

Trim						
	Manuf.	Model / Series	Color / Finish	Remarks	Clinical	Non-Clinical
	Schluter	Varies	Varies (See manuf. info)		*	*

G. WINDOW SILLS / CONVECTOR

Plastic Laminate						
	Manuf.	Model / Series	Color / Finish	Remarks	Clinical	Non-Clinical
Wood Grain and Solid	Formica	Varies	Varies (See manuf. info)		*	*
	Nevamar	Varies	Varies (See manuf. info)		*	*
	Pionite	Varies	Varies (See manuf. info)		*	*
	Wilsonart	Varies	Varies (See manuf. info)		*	*

Solid Surface						
	Manuf.	Model / Series	Color / Finish	Remarks	Clinical	Non-Clinical
	Corian	Varies	Varies (See manuf. info)		*	*
	Formica	Varies	Varies (See manuf. info)		*	*
	Wilsonart	Varies	Varies (See manuf. info)		*	*

Painted Metal						
	Manuf.	Model / Series	Color / Finish	Remarks	Clinical	Non-Clinical
	Varies	Varies	Varies (See manuf. info)	Electrostatic Painted Alum. Gauge to-withstand a person standing on it.	*	*

H. WINDOW TREATMENTS

Shadecloth						
	Manuf.	Model / Series	Color / Finish	Remarks	Clinical	Non-Clinical
	Phifer	Sheerweave, Infinity 2		Sun Control, 1, 3 or 5% openness; PVC and phthalate-free shade fabrics	*	*
	Phifer	Sheerweave, Style 7000		Black out; PVC and phthalate-free shade fabrics	*	*
	Phifer	Sheerweave, Style 8000		Sun Control, 3% openness; PVC and phthalate-free shade fabrics	*	*
Notes: 1. Provide dual color shades typically. Dark color facing outwards. Light color facing inwards. 2. Confirm type of shade used in existing building prior to specifying. Review with RED+F’s Design Studio. 3. Shades shall be owner provided, owner installed. 4. Percentage openness to be verified with Design Studio. 5. Provide shades operating from sill upward at windows overlooking public areas such as onto a sidewalk or terrace.						

Sheers						
	Manuf.	Model / Series	Color / Finish	Remarks	Clinical	Non-Clinical
	Carnegie	Varies	trevira		*	*
	Innovations	Varies	trevira		*	*
	Knoll	Varies	trevira		*	*
	Maharam	Varies	trevira		*	*
	Luum	Varies	trevira		*	*
Notes: 1. Trevira CS and FR are not permitted.						

I. SHOWER CURTAINS

Standard Fabrics						
	Manuf.	Model / Series	Color / Finish	Remarks	Clinical	Non-Clinical
	Varies	100% trevira	Varies (See manuf. info)	No mesh, weighted bottom, 10” off floor	*	*
Notes: 1. Trevira CS and FR are not permitted. 2. Provide 100% attic stock. 3. Use cubicle track hardware.						

J. CUBICLE CURTAINS

Standard Fabrics						
	Manuf.	Model / Series	Color / Finish	Remarks	Clinical	Non-Clinical
	Arc Com	Nami	AC-33101 Color: Surf #2	Tisch Hospital and NYU Langone Orthopedic Hospital Patient Rooms	*	
	Arc Com	Papillion-X	AC-33190 Color: Spring	ED Pediatric Treatment Areas	*	
	Arc Com	Woodland	AC-32762 Color: Spring #3	ED Adult Treatment Areas	*	
	Carnegie	Canopy	4238 Color: 2	Tisch Hospital 12 West	*	
	Maharam	Progression 3 511517	Color: 009 Kaleidoscope	Pediatric Areas	*	
	Maharam	Sing 511490	Color: 004 Breeze	NYU Langone Hospital - Long Island	*	
	Maharam	Sway 511496	Color: 002 Washed	Tisch Hospital and NYU Langone Hospital - Brooklyn	*	

Notes:

1. NYULH will make selections for each site and each hospital building will have one fabric associated with it.
2. The fabric selection should be limited to 100% Trevira or polyester blend. Trevira CS and FR are not permitted.
3. Silver ion anti-microbial fabrics will be considered but any fabric with an antimicrobial additive or finish will not be considered acceptable for use in any NYULH facility.
4. Cubicle curtains shall be owner provided, owner installed.
5. Contractor to provide and install cubicle track and carriers. See Cubicle Track subsection below.

Curtain Fabrication:

1. Top hem to be 1-½” wide triple thick and reinforced with permanent, washable type buckram. Nickel-plated brass grommets to be placed 6” on center across the top of the curtain.
2. Side and bottom hems to be ½” wide double thick and double stitched.
3. Vertical seams to be double needle lock stitched.
4. Where mesh is specified, it is to be 22” high, excluding hems, per NYC fire code.
5. All curtain widths are expressed in feet, height in inches. All curtain heights are including mesh, if any. Curtain lengths shall be 10”-12” off the floor, per NYC fire code.
6. Fabric shall be joined to mesh with double hem stitch construction, and matching fabric ½” band where mesh and curtain are joined in back. Sides of curtain mesh is also to have matching fabric on edges.
7. In critical care areas only, the leading edge of each curtain is to have a 6’ snap out panel made of matching fabric. This panel is to be snapped below the mesh and overlap the main panel by 21”. No snaps shall be provided vertically. Each leading panel shall be provided with two weights in the bottom, one at each corner.
8. Curtains are to be supplied with weights in the bottom.

Attic Stock:

1. Provide 100% of entire curtain order as spares.
2. When using 6’ snap panels, provide 100% spares of the 6’ panels and 25% of entire curtain order as spares for each area.
3. Curtains are to come tagged with size and location for ease of maintenance when removed for cleaning.





K. CUBICLE TRACK





Cubicle Track						
	Manuf.	Model / Series	Color / Finish	Remarks	Clinical	Non-Clinical
Cubicle Track	C-S Group	#6062 cubicle curtain track	Clear anodized aluminum	Surface-mounted tracks of heavy extruded aluminum alloy 6063-T5, 1- ³ / ₈ " x ³ / ₄ ", slotted to receive roller carriers	*	
	Notes: 1. Cubicle curtain track shall be provided with all accessories and components required for complete and secure installation including splicers, end caps and corner bends. 2. Corner bends shall have a 12" radius fabricated in one continuous "L" shape.					
	Manuf.	Model / Series	Color / Finish	Remarks	Clinical	Non-Clinical
Loading Unit	C-S Group	Qwik Switch Track System	Clear anodized aluminum	Hinged unit of track that allows for the safe removal of curtains from the track without the use of a ladder or step stool.	*	
	Notes: 1. Provide one Qwik Switch unit for each run of track. 2. Qwik Switch unit to include: Hinge, Locking unit, and Latch. 3. The hinge unit of track, when lowered, is to bring the track end and curtains down to four feet above the finished floor so the curtain can be removed from the carriers. 4. Provide one Qwik Switch Release Wand for every 20 units of track.					
	Manuf.	Model / Series	Color / Finish	Remarks	Clinical	Non-Clinical
Carriers	C-S Group	CS Standard Carrier 1062N		virgin nylon axle with nylon wheels complete with nickel-plated brass bead-chain and hook assembly.	*	
	Notes: 1. Provide one carrier for each 6" of cubicle curtain width.					

PAINT COLORS

In order to create and maintain a consistent brand and allow appropriate maintenance at NYU Langone Health spaces, there are specific paint colors we utilize. The list below will give the A/E Team a sense of the preferred color palettes at NYU Langone and help inform the interior finish selections. The typical wall and ceiling colors must be from the list below (i.e. “Off-Whites” and “Ceiling White”). Accent wall colors other than those listed will be considered if it is deemed necessary by the RED+F Design Studio. For walls and ceilings Benjamin Moore, EcoSpec products shall be used, unless noted otherwise in the Room Finish Schedules. For painted elevator doors and frames Scuffmaster, Solid Metal interior paints shall be used, as noted in the Room Finish Schedules.

Note: The color swatches shown in the tables below are for reference only. A/E Team shall obtain actual BM color swatches for design, material presentation and approval.







TYPICAL LOGO AND PATHWAY COLORS			
NYU Purple	Green Pathway	Yellow Pathway	Blue Pathway
			
Name: Mystical Grape BM #: 2071-30 Pantone #: 2597C	Name: Cat’s Eye BM #: 2036-10	Name: Jack o’Lantern BM #: 2156-30	Name: Santa Monica Blue BM #: 776

TYPICAL WALL AND CEILING COLORS			
Ceiling White			
			
Name: Decorator’s White BM #: PM-3			
Off-Whites			
			
Name: Pure White BM #: OC-64	Name: Seapearl BM #: OC-19	Name: White Down BM #: OC-131	Name: American White BM #: 2112-70

 <p>Name: Pale Oak BM #: OC-20</p>	 <p>Name: April Showers BM #: 1507</p>		
Neutrals			
 <p>Name: Mineral Ice BM #: 2132-70</p>	 <p>Name: White Sand BM #: OC-10</p>	 <p>Name: Sea Froth BM #: 2107-60</p>	 <p>Name: Cement Gray BM #: 2112-60</p>
 <p>Name: Metallic Silver BM #: 2132-60</p>	 <p>Name: Cumulus Cotton BM #: 2063-70</p>		

TYPICAL ACCENT WALL COLORS			
Blue Greens			
 <p>Name: Boca Raton Blue BM #: 711</p>	 <p>Name: Caribbean Teal BM #: 2123-20</p>	 <p>Name: Beach Glass BM #: 1564</p>	
Greens			
 <p>Name: Kennebunkport Green BM #: HC-123</p>	 <p>Name: Boreal Forest BM #: AF-480</p>		

Blues			
 Name: Winter Lake BM #: 2129-50	 Name: Fiji BM #: AF-525	 Name: Old Blue Jeans BM #: 839	 Name: Downpour Blue BM #: 2063-20
Reds			
 Name: Shy Cherry BM #: 2007-20	 Name: Cranberry Cocktail BM #: 2083-20		
Purples			
 Name: Bonne Nuit BM #: AF-635	 Name: Sea Life BM #: 2118-40	 Name: Shadow BM #: 2117-30	
Yellows			
 Name: Straw BM #: 2154-50	 Name: Bryce Canyon BM #: 098		
Grays			
 Name: Cinder BM #: AF-705	 Name: Smoke Gray BM #: 2120-40		

TYPICAL ELEVATOR DOOR AND FRAME COLORS			
Metallic			
 <p>Name: Solid Metal SM #: SM10231 WG #: GOH 31951841</p>	 <p>Name: Solid Metal SM #: SM10232 WG #: GOH 31951842</p>	 <p>Name: Solid Metal SM #: SM10237 WG #: GOH 31951844</p>	 <p>Name: Solid Metal SM #: SM10238 WG #: GOH 31951845</p>
 <p>Name: Solid Metal SM #: SM10244 WG #: GOH 31951846</p>	 <p>Name: Solid Metal SM #: SM10250 WG #: GOH 31951847</p>	 <p>Name: Solid Metal Satin Sheen SM #: SM159 WG #: GOH 31951848</p>	

ART PROGRAM

NYU Langone Health has embarked on a comprehensive visual arts program of the highest quality consistent with our mission devoted to excellence in patient care, education, and research. The NYU Langone Health Art Program and Collection is integrated into the daily life of our organization providing a life-affirming, healing and supportive environment for patients, families, caregivers, students, faculty and staff. This is achieved through acquisitions, exhibitions, donations of art and other related visual arts programming. Acquisitions meet overall quality standards with the aim that the art collection appreciates in value over time.

1. Importance of Art in a Healthcare Environment

- Over the past decade, art has become an integral component in healthcare environments. As indicated in the [State of the Field Report: Arts in Healthcare/2009](#) survey, nearly half of all healthcare institutions reported having arts in healthcare programs with the majority of these in hospital settings. Studies have shown that these programs improve patients' overall health outcomes, treatment compliance and quality of life, and foster a positive environment for caregivers that reduces stress and improves workplace satisfaction and employee retention.



Spot (2018) © Donald Lipski. NYU Langone Art Program and Collection. Hassenfeld Children's Hospital. Photo © Jeff Goldberg/Esto

2. Means of Selecting Art

- The Design Studio's Art Group at RED+F identifies and acquires art through gallery visits, studio visits, recommendations as provided by museum curators, art critics and contemporary art historians and Calls to Artists as posted on visual art websites (New York Foundation for the Arts, Public Arts Network, etc.)

3. Capital Construction Projects

Many capital construction projects provide excellent opportunities to integrate art into the design of these new facilities.

- Emphasis will focus on public spaces with higher visibility resulting in greater impact.
- For patient areas, the inclusion and placement of artwork will be a calming distraction.
- Placement of artwork will also support wayfinding efforts.
- Goal is to create a singular vision and identity throughout an individual project through selection and placement of artwork.
- Selection of site-specific artwork will involve input from user-groups occupying the space.
- Art will be selected from a range of artists, from emerging to established.



Energy of Endless Universe (Ekpyrotic String VI) © Mariko Mori. NYU Langone Art Program and Collection. Science Building. Photo © Rene Perez

4. Architect's Responsibilities

Where art integration is part of the project scope, art selection will be the responsibility of the Design Studio's Art Group at RED+F. The A/E Team shall assist with identifying locations for art placement in a project including but not limited to the following:

- During Design Development, the architect will work with the Art Manager, Project Manager and users to identify potential locations for art.
- The A/E Team shall provide drawings sufficient to identify proposed art locations including plans, elevations and perspectives.
- The A/E Team will be responsible for keeping any walls that have been identified for artwork integration, free and clear of any and all electrical devices, room and directional signage, or other potentially distracting items. This includes electrical outlets, telephone/data outlets, light switches, thermostats, fire strobes, furniture, etc.
- The A/E Team shall ensure the art has proper lighting.

ROOM NUMBERING, SIGNAGE & WAYFINDING

The architect is required to use RED+F’s assigned room numbers, and provide full design and programming services related to signage and wayfinding. The A/E Team shall follow the NYU Langone Wayfinding and Communications Standards Manual, available on the Real Estate Development and Facilities website at: <http://nyulangone.org/vendor-information/design-guidelines>. The manual specifies each signage type approved for use at NYU Langone Health facilities. For off-campus projects, the A/E Team shall follow these guidelines in conjunction with any building landlord requirements.

1. Architect’s Responsibilities

- The architect shall submit the signed-off floor plans to the Space Planning and Management Group at RED+F who shall assign the room numbers. The architect shall insert these room numbers on the drawings. RED+F will not accept any other room numbers shown on the documents.
- Confirm the Room Number Prefix (if any) with the Design Studio’s Signage/Wayfinding Group at RED+F. The architect shall use this Room Number Prefix to produce their signage programming documents.
- Confirm requirements for code required emergency/egress signage (i.e. stair and elevator fire egress maps and messaging) and health/safety signage (i.e. chemical, laboratory, hazardous material, radiation, etc.) with Environmental Health & Safety (EH&S) at RED+F.
- Present signage design options to the Signage/Wayfinding Group.
- Produce signage programming documents that include location plans and message schedules for review and approval by the Signage/Wayfinding Group.
- Review and approve shop drawings. Shop drawings are also to be forwarded to the Signage/Wayfinding Group for their review and approval.
- Punchlist installed signage in coordination with Signage/Wayfinding Group.
- Final acceptance of the signage in conjunction with the Signage/Wayfinding Group.

Architects, or their consultant, shall be responsible for signage/wayfinding on capital projects. Where there is no architect, signage/wayfinding shall be the responsibility of the Signage/Wayfinding Group. The sign design package may be created by the Architect, a pre-approved signage consultant or one of the NYU Langone-approved signage vendors. If available, SignAgent shall be used to upload and share project documentation with NYULH and the signage fabricator/installer. When used, NYULH shall be granted visibility, access and full ownership permissions to any project documentation managed with SignAgent.



2. Sign Planning and Programming Process

There are five groups of signs comprising the NYU Langone system: identification, directional, informational, regulatory, and pageantry. Before programming a facility's signs, the complete sign typology (contained within the NYU Langone Wayfinding and Communications Standards Manual) should be understood by the signage programmer. The following outlines a step-by-step approach for sign planning and programming.

- **Analysis** - When planning and programming signs the programmer shall know the architectural layout, be familiar with the day-to-day operations and activities of the end-users within the space and consider the perspective of first-time visitors. Whenever possible, it is recommended that the sign programmer(s) meet with end-users to review how the facility will function.

The programmer should explore various visitor scenarios, and locate wayfinding decision points (both clear and obscure) along arrival and departure routes. Consider the route distances and turns from start to end point.

Typical questions to ask: Where are the restricted-access areas, and for what reasons? Who are the visitors, and for what purposes? What kind of sign types are needed, and where?

- **Visualization of the Space** - The programmer should imagine a “visitor-eye-view” through the department. The programmer should enhance comprehension of the architectural character of the visitor experience, of walking the hallways, facing impaired sightlines, or seeking visual landmarks. High and low ceiling space should be noted, along with wall position and angle, both on first entry and closer approach. The programmer should visualize the look and feel of the spaces, and identify optimal sign locations for decision points, avoiding obstacles. If possible, the programmer should suggest the architect revisit particular design details to accommodate sign locations.

Typical questions to ask: Are doors or walls opaque or transparent? What color is the wall finish behind reception, and how tall? Is there any art or furniture nearby when determining placement of signage? Are there any devices (electrical outlets, light switches, thermostats, fire alarm strobes, etc.) or other signs nearby that should be considered when determining placement of signage (with respect to height, alignment, etc.)?

- **Programming Documentation & Clarification** - The programmer should issue documents for sign vendors to produce message layouts and shop drawings. Draft documents should be submitted to the RED+F PM, end-user representative, and the Design Studio's Signage/Wayfinding Group at RED+F for approval and comments. A unique sign number shall designate floor/location ID (if applicable), designation ID and sign type ID.

Typical questions to ask: What is the proper name of the facility? Are there any donor recognition signs?

FURNITURE

In accordance with both our Mission devoted to excellence in patient care, education, and research and our Design Principles of providing timeless designs that are cost effective, efficient, functional and practical, RED+F has compiled a collection of furniture and accessory items that we have found to be successful at NYU Langone Health.

Our goals in listing these items are to:

- Streamline the design process
- Assist the Architect and Interior Designer with specifying furniture and accessory items
- Comply with the Practice Greenhealth [Healthcare Without Harm: Safer Chemicals Challenge](#), eliminating the use of formaldehyde, perfluorinated compounds, polyvinyl chloride (PVC), antimicrobials, and all flame retardants from all furniture and finishes
- Create spaces that are timeless, durable, easily maintainable and cost-effective
- Create a consistent NYU Langone brand

The Architect and Interior Designer should use this as a guide for specifying furniture and accessories on NYU Langone capital projects. This information does not relieve the Architect or Interior Designer of specifying products that are appropriate and code compliant for specific spaces. The Architect and Interior Designer shall consider specifying existing building-specific standards provided they are in line with these Design Guidelines. Also, the Architect and Interior Designer may suggest other products if they believe those proposed products will support our mission, design principles, and the design intent of the project.

The product specifications included in this subsection are organized by type as follows:

- A. Case Goods
- B. Prefab Casework
- C. Workstations
- D. Tables
- E. Seating
- F. Storage
- G. Accessories
- H. Outdoor Furniture

Note: For trash and recycling receptacles see the Recycling Program subsection of these Design Guidelines.

A. CASEGOODS

In order to create and maintain a consistent brand and allow appropriate maintenance at NYU Langone Health spaces, specific furniture and accessory items are used. The list below will give the A/E Team a sense of the typical casegoods used at NYU Langone facilities. It is the Architect’s responsibility to select items that are code compliant and appropriate for the capital project based on the type of space and end-user needs. The Architect and Interior Designer shall consider specifying existing building-specific standards provided they are in line with these Design Guidelines. Architects shall coordinate with the RED+F Project Manager and the Design Studio to finalize casegood selections. The images shown are for illustrative purposes only and may not be a reflection of a project’s final specification. Please note the following requirements as they pertain to casegoods:

- All substrate shall be formaldehyde free.
- All wood office desks and credenzas are for use in VP level offices and above.
- Convenience outlets should be accessible above the worksurface.
- Credenza and/or lectern selection must be coordinated with the NYU Langone AV/IT team. Any proposed alternates must be similarly vetted.





Cost-saving Alternatives:



The RED+F PM will advise the A/E Design Team if items identified as Cost-saving Alternatives shall be allowed on their project. There may be risks associated with using such items, including the need to repair or replace them more often, but it has been determined they are within acceptable range for use on certain NYU Langone Health projects.

The product specifications included in this subsection are organized by type as follows:

- F-A1 Private Office
- F-A2 Lecterns

F-A1 PRIVATE OFFICE				
Geiger		Model	Clinical	Non-Clinical
F-A1a		Levels		*
		Location: <i>Private Office</i> Remarks: Consult with RED+F for approved finishes and typical layouts. Provide wood front overheads (Catalyst model). Include wardrobe if possible.		

Steelcase		Model	Clinical	Non-Clinical
F-A1b		EE6		*
		Location: <u>Private Office</u> Remarks: Consult with RED+F for approved finishes and typical layouts. Provide wood or glass front overheads. Include wardrobe if possible.		
F-A1 PRIVATE OFFICE (COST-SAVING ALTERNATIVES)				
Herman Miller		Model	Clinical	Non-Clinical
F-A1c		Canvas		*
		Location: <u>Private Office</u> Remarks: Consult with RED+F for typical layouts in laminate. Provide laminate or metal overheads. Include wardrobe if possible.		
Steelcase		Model	Clinical	Non-Clinical
F-A1d		Answer		*
		Location: <u>Private Office</u> Remarks: Consult with RED+F for typical layouts in laminate. Provide laminate or metal overheads. Include wardrobe if possible.		
Three h		Model	Clinical	Non-Clinical
F-A1e		Premier		*
		Location: <u>Private Office</u> Remarks: Consult with RED+F for typical layouts in laminate. Provide overheads and wardrobe if possible.		
Teknion		Model	Clinical	Non-Clinical
F-A1f		Expansion		*
		Location: <u>Private Office</u> Remarks: Consult with RED+F for typical layouts in laminate. Provide overheads and wardrobe if possible.		

F-A2 LECTERNS				
Custom		Model	Clinical	Non-Clinical
F-A2a		Custom		*
		Location: <u>Lecture Hall / Auditorium</u> Remarks: Consult with AV/IT and RED+F for lectern design and drawings.		
F-B2 LECTERNS (COST-SAVING ALTERNATIVES)				
Nucraft		Model	Clinical	Non-Clinical
F-A2b		High Tech Lectern / Column		*
		Location: <u>Seminar / Multipurpose Room</u> Remarks: Consult with AV/IT and RED+F for lectern requirements and preferred model.		



B. PREFAB CASEWORK



In order to create and maintain a consistent brand and allow appropriate maintenance at NYU Langone Health spaces, specific furniture and accessory items are used. The list below will give the A/E Team a sense of the typical prefabricated casework used at NYU Langone facilities. It is the Architect’s responsibility to select items that are code compliant and appropriate for the capital project based on the type of space and end-user needs. The Architect and Interior Designer shall consider specifying existing building-specific standards provided they are in line with these Design Guidelines. Architects shall coordinate with the RED+F Project Manager and the Design Studio to finalize casework selections. The images shown are for illustrative purposes only and may not be a reflection of a project’s final specification. Please note the following requirements as they pertain to casework:

- All substrate shall be formaldehyde free.
- Convenience outlets should be accessible above the worksurface.

The product specifications included in this subsection are organized by type as follows:

- F-B1 Prefab Casework
- F-B2 Casework Hardware

F-B1 PREFAB CASEWORK				
Herman Miller		Model	Clinical	Non-Clinical
F-B1a		Ethospace	*	
		Location: <u>Nurse / MA Station</u> Remarks:		
OFS Carolina		Model	Clinical	Non-Clinical
F-B1b		Mile Marker	*	*
		Location: <u>Gown Waiting / Dressing</u> <u>Exam Room / Patient Room</u> <u>Family Lounge / Waiting /</u> <u>Pantry / Lactation Room</u> Remarks: Clinical Space Millwork System Provide only if custom millwork is not a viable option.		

Dirtt		Model	Clinical	Non-Clinical
F-B1c		Dirtt Casework	*	
		Location: <u>Gown Waiting / Dressing / Exam Room / Patient Room</u> Remarks: Clinical Space Millwork System Provide only if custom millwork is not a viable option.		
Herman Miller		Model	Clinical	Non-Clinical
F-B1d		Mora	*	
		Location: <u>Gown Waiting / Dressing / Exam Room / Patient Room</u> Remarks: Clinical Space Millwork System Provide only if custom millwork is not a viable option.		
Groupe Lacasse		Model	Clinical	Non-Clinical
F-B1e		Neocase	*	
		Location: <u>Exam Room / Patient Room</u> Remarks: Clinical Space Millwork System Provide only if custom millwork is not a viable option.		

F-B2 CASEWORK HARDWARE				
Hafale		Model / Finish	Clinical	Non-Clinical
F-B2a		Veranda Bar Handle #117.05.600/ #304 Stainless Steel	*	
		Location: <u>Casework</u> Remarks: 3.78" hole spacing, 5.74" length, 1.45" depth, 0.55" thickness		



C. WORKSTATIONS



In order to create and maintain a consistent brand and allow appropriate maintenance at NYU Langone Health spaces, specific furniture and accessory items are used. The list below will give the A/E Team a sense of the typical workstations used at NYU Langone facilities. It is the Architect’s responsibility to select items that are code compliant and appropriate for the capital project based on the type of space and end-user needs. The Architect and Interior Designer shall consider specifying existing building-specific standards provided they are in line with these Design Guidelines. Architects shall coordinate with the RED+F Project Manager and the Design Studio to finalize workstation selections. The images shown are for illustrative purposes only and may not be a reflection of a project’s final specification. Please note the following requirements as they pertain to workstations:

- All substrate shall be formaldehyde free.
- Convenience outlets should be accessible above the worksurface.
- Vertical storage is preferred to overhead storage.

Cost-saving Alternatives:

The RED+F PM will advise the A/E Design Team if items identified as Cost-saving Alternatives shall be allowed on their project. There may be risks associated with using such items, including the need to repair or replace them more often, but it has been determined they are within acceptable range for use on certain NYU Langone Health projects.

F-C1 WORKSTATIONS				
Steelcase		Model	Clinical	Non-Clinical
F-C1a		Answer		*
		Location: <u>Open Work Area</u> Remarks: Consult with RED+F for approved finishes and typical layouts.		
Herman Miller		Model	Clinical	Non-Clinical
F-C1b		Canvas		*
		Location: <u>Open Work Area</u> Remarks: Consult with RED+F for approved finishes and typical layouts.		

Teknion		Model	Clinical	Non-Clinical
F-C1c		Leverage		*
		Location: <u>Open Work Area</u> Remarks: Consult with RED+F for approved finishes and typical layouts.		
F-C1 WORKSTATIONS (COST-SAVING ALTERNATIVES)				
Three h		Model	Clinical	Non-Clinical
F-C1d		Multistations+		*
		Location: <u>Open Work Area</u> Remarks: Consult with RED+F for approved finishes and typical layouts. Laminate only.		
CBR		Model	Clinical	Non-Clinical
F-C1e		Standard		*
		Location: <u>Open Work Area</u> Remarks: Consult with RED+F for approved finishes and typical layouts.		

D. TABLES

In order to create and maintain a consistent brand and allow appropriate maintenance at NYU Langone spaces, specific furniture and accessory items are used. The list below will give the A/E Team a sense of the typical tables used at NYU Langone facilities. It is the Architect’s responsibility to select items that are code compliant and appropriate for the capital project based on the type of space and end-user needs. The Architect and Interior Designer shall consider specifying existing building-specific standards provided they are in line with these Design Guidelines. Architects shall coordinate with the RED+F Project Manager, NYU Langone AV/IT and the Design Studio to finalize table selections. The images shown are for illustrative purposes only and may not be a reflection of a project’s final specification. Please note the following requirements as they pertain to tables:



- All substrate shall be formaldehyde free.
- Table selection must be coordinated with the NYU Langone AV/IT team. Any proposed alternates must be similarly vetted.
- Coordinate power/data troughs and core drill requirements with the NYULH Furniture Dealer, Architect or NYU Langone AV/IT.
- Plug-in tables in public areas must be UL-approved and have USB and outlet options.
- Occasional tables in public areas must be provided with power and data.
- Furnishings for In-Patient Rooms have been evaluated by Nursing, Epidemiology, Facilities Operations, Environmental Services, Rehabilitation Medicine and Sustainability. All proposed alternates must be similarly vetted.





Cost-saving Alternatives:

The RED+F PM will advise the A/E Design Team if items identified as Cost-saving Alternatives shall be allowed on their project. There may be risks associated with using such items, including the need to repair or replace them more often, but it has been determined they are within acceptable range for use on certain NYU Langone Health projects.

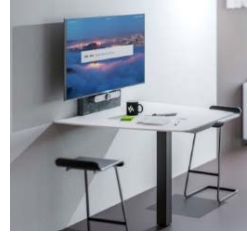
The product specifications included in this subsection are organized by type as follows:

- F-D1 Conference Tables with Integrated Technology
- F-D2 Conference Tables without Power
- F-D3 Self-Check-in Tables (where built-in counter is not feasible)
- F-D4 Height Adjustable Bases
- F-D5 Training Tables
- F-D6 Café Tables
- F-D7 Occasional Tables with Power / USB Outlets
- F-D8 Occasional Tables without Power
- F-D9 Patient Tables





F-D1 CONFERENCE TABLES WITH INTEGRATED TECHNOLOGY				
Bernhardt		Model	Clinical	Non-Clinical
F-D1a		Trace		*
		Location: <u>Conference Room</u> Remarks: Typical table approved for NYU Langone Health; Floor stub-ups to be noted as “VIF”. Final location to be identified in field by NYULH Furniture Dealer.		
Bernhardt		Model	Clinical	Non-Clinical
F-D1b		a.k.a. wall		*
		Location: <u>Conference Room / Discussion Room</u> Remarks: Coordinate power and data requirements with MCIT. Top and base ordered separately. Bullnose end for top available. Coordinate base location with power and data feeds. Provide ganging kit to attach table to credenza/wall assembly unit.		
Salamander		Model	Clinical	Non-Clinical
F-D1c		Unifi Huddle		*
		Location: <u>Discussion Room</u> Remarks: Coordinate power and data requirements with MCIT. Coordinate finish selection with RED+F.		
Salamander		Model	Clinical	Non-Clinical
F-D1d		Unifi Huddle Lite		*
		Location: <u>Discussion Room</u> Remarks: Coordinate power and data requirements with MCIT. Coordinate finish selection with RED+F.		
Notes: 1. Conference Rooms with occupancy of 12 or more persons require a trash/recycling credenza. Refer to the Recycling Program subsection of these Design Guidelines for additional information.				





F-D2 CONFERENCE TABLES WITHOUT INTEGRATED TECHNOLOGY				
Steelcase		Model	Clinical	Non-Clinical
F-D2a		Convene		*
		Location: <u>Conference Room</u> Remarks: Floor stub-ups to be noted as “VIF”. Final location to be identified in field by NYULH Furniture Dealer. Coordinate power and data requirements with MCIT.		
Coalesse		Model	Clinical	Non-Clinical
F-D2b		SW1		*
		Location: <u>Conference Room</u> Remarks: Coordinate power and data requirements with MCIT.		
Nevins		Model	Clinical	Non-Clinical
F-D2c		Elite		*
		Location: <u>Conference Room</u> Remarks: Coordinate power and data requirements with MCIT.		
F-D2 CONFERENCE TABLES WITHOUT INTEGRATED TECHNOLOGY (COST-SAVING ALTERNATIVES)				
Steelcase		Model	Clinical	Non-Clinical
F-D2d		Universal		*
		Location: <u>Conference Room</u> Remarks: Coordinate power and data requirements with MCIT.		





Herman Miller		Model	Clinical	Non-Clinical
F-D2e		Everywhere		*
		Location: <u>Conference Room</u> Remarks: Coordinate power and data requirements with MCIT.		
Notes: 1. Conference Rooms with occupancy of 12 or more persons require a trash/recycling credenza. Refer to the Recycling Program subsection of these Design Guidelines for additional information.				



F-D3 SELF-CHECK-IN TABLES (where built-in counter is not feasible)				
Arcadia		Model	Clinical	Non-Clinical
F-D3a		Avelina		*
		Location: <u>Self-Check-in Kiosks</u> Remarks: Permitted for self-check-in kiosks only when built-in millwork counter is not feasible (Approval by RED+F required). Single-station: 30" w x 20" d x 34" h w/ 1x PP1-DC* Double-station: 60" w x 20" d x 34" w/ 2x PP1-DC* Triple-station: 90" w x 20" d x 34" h w/ 3x PP1-DC* * PP1-DC power/data accessories shall be nickel finish, inclusive of female/female data port, and located 4" o.c. from back of table, 15" o.c. from either end of table, and 30" o.c. between units where more than 1 is provided.		



F-D4 HEIGHT ADJUSTABLE BASES				
Steelcase		Model	Clinical	Non-Clinical
F-D4a		Ology		*
		Location: <u>Workstation</u> Remarks: Worksurface height range is 22.6" – 48.7". Power required. Coord outlet location w/ power cord length.		





Herman Miller		Model	Clinical	Non-Clinical
F-D4b		Renew		*
		Location: <u>Workstation</u> Remarks: Worksurface height range is 22” – 48”. Electric extended. Coor’d outlet location w/ power cord length.		
F-D4 HEIGHT ADJUSTABLE TABLES (COST-SAVING ALTERNATIVES)				
Gen2 Office Furniture		Model	Clinical	Non-Clinical
F-D4c		Gen2 Up		*
		Location: <u>Workstation</u> Remarks: Work surface height range is 25-50”. 1” leveling glides can add up to 3-3/4” of adjustment. Power required. Coor’d outlet location w/ power cord length. Worksurface not included.		
Humanscale		Model	Clinical	Non-Clinical
F-D4d		Float		*
		Location: <u>Workstation</u> Remarks: Pneumatic, power not required. Worksurface not included.		
Humanscale		Model	Clinical	Non-Clinical
F-D4e		Efloat Go 2.0		*
		Location: <u>Workstation</u> Remarks: Accommodates worksurfaces 48” - 72” long x 24” - 30” deep. Power required. Coor’d outlet location w/ power cord length. Worksurface not included.		



F-D5 TRAINING TABLES				
Nucraft		Model	Clinical	Non-Clinical
F-D5a		Fleet		*
		Location: <u>Training Room / Multipurpose</u> Remarks: Nesting training tables available with optional ganging connectors, variety of table leg configurations and power/data accessories.		
Halcon		Model	Clinical	Non-Clinical
F-D5b		Skill		*
		Location: <u>Training Room / Multipurpose</u> Remarks: Nesting training tables available with optional ganging connectors, variety of table leg configurations and power/data accessories.		
F-D5 TRAINING TABLES (COST-SAVING ALTERNATIVES)				
Senator		Model	Clinical	Non-Clinical
F-D5c		Array		*
		Location: <u>Training Room / Multipurpose</u> Remarks: Rectangular C-Leg, flip top table		
Arcadia		Model	Clinical	Non-Clinical
F-D5d		Flirt		*
		Location: <u>Training Room / Multipurpose</u> Remarks:		



F-D6 CAFÉ TABLES				
Nevins		Model	Clinical	Non-Clinical
F-D6a		Atlantis Series Table & Disc w/ Cover base		*
		Location: <u>Cafeteria / Public Spaces / Administrative Spaces</u> Remarks: Spec with Krystal Cast for Cafeteria / Public Spaces. Spec with formica for Administrative use. Coor'd edge detail w/ RED+F.		
F-D6 CAFÉ TABLES (COST-SAVING ALTERNATIVES)				
Herman Miller		Model	Clinical	Non-Clinical
F-D6b		Everywhere		*
		Location: <u>Cafeteria / Public Spaces / Administrative Spaces</u> Remarks:		
Leland		Model	Clinical	Non-Clinical
F-D6c		M2		*
		Location: <u>Staff Lounge / Cafeteria</u> Remarks:		
Steelcase		Model	Clinical	Non-Clinical
F-D6d		Universal		*
		Location: <u>Staff Lounge / Administrative Spaces</u> Remarks:		



F-D7 OCCASIONAL TABLES (WITH POWER / USB OUTLETS)				
Nevins		Model	Clinical	Non-Clinical
F-D7a		Adler Drum		*
		Location: <u>Lobby / Waiting Area</u> Remarks: Spec with side power/data port installation only. Must spec mouse hole when plugging into wall outlet. Top shall be wood, solid surface, quartz or resin. Stainless Steel Outlet: COV-2US-V Black Outlet: COV-2UB-V Gloss White Outlet: COV2UW-V		
Nevins		Model	Clinical	Non-Clinical
F-D7b		Abbott Cube		*
		Location: <u>Lobby / Waiting Area</u> Remarks: Spec with side power/data port installation only. Must spec mouse hole when plugging into wall outlet. Spec plinth for use with floor outlet. Top shall be wood, solid surface, quartz or resin. Stainless Steel Outlet: COV-2US-V Black Outlet: COV-2UB-V Gloss White Outlet: COV2UW-V		

F-D8 OCCASIONAL TABLES WITHOUT POWER				
Bernhardt		Model	Clinical	Non-Clinical
F-D8a		Chance		*
		Location: <u>Lobby / Waiting Area</u> Remarks: Top surface to be either Corian or wood. Spec at 23" or 27" high.		
Studio TK		Model	Clinical	Non-Clinical
F-D8b		Envita		*
		Location: <u>Lobby / Waiting Area</u> Remarks: Available as task / occasional tables and square / rectangle coffee table. Top surface to be either Corian or wood.		

F-D8 OCCASIONAL TABLES WITHOUT POWER (COST-SAVING ALTERNATIVES)				
Krug		Model	Clinical	Non-Clinical
F-D8c		Faeron		*
		Location: <u>Lobby / Waiting Area / Lactation Room</u> Remarks: Available as side and coffee table. For Lactation Rooms provide side table with solid surface top and wood base to match approved Krug Faeron Lounge Chair (Highback).		
Arcadia		Model	Clinical	Non-Clinical
F-D8d		Flirt Occasional Table		*
		Location: <u>Lobby / Waiting Area</u> Remarks: Available as side and coffee table		
Nevins		Model	Clinical	Non-Clinical
F-D8e		Adler Drum		*
		Location: <u>Lobby / Waiting Area</u> Remarks: Top shall be wood, solid surface, quartz or resin.		
Nevins		Model	Clinical	Non-Clinical
F-D8f		Abbott Cube		*
		Location: <u>Lobby / Waiting Area</u> Remarks: Top shall be wood, solid surface, quartz or resin.		
Coalesse		Model	Clinical	Non-Clinical
F-D8g		Await		*
		Location: <u>Lobby / Waiting Area / Lactation Room</u> Remarks:		

Koleksiyon		Model	Clinical	Non-Clinical
F-D8h		Bremen		*
		Location: <u>Lobby / Waiting Area / Lactation Room</u> Remarks:		
Peter Pepper		Model	Clinical	Non-Clinical
F-D8i		Pickup		*
		Location: <u>Lobby / Waiting Area</u> Remarks: 23" high portable and stackable table		

F-D9 PATIENT TABLES				
Kimball		Model	Clinical	Non-Clinical
F-D9a		Sanctuary	*	
		Location: <u>Patient Room</u> Remarks: Bedside table with Corian top. Spec with one locked drawer and unlocked cabinet door below. Cabinet door is handed. Specify left or right opening.		
Kwalu		Model	Clinical	Non-Clinical
F-D9b		Auburn	*	
		Location: <u>Patient Room</u> Remarks: Bedside table with Corian top. Spec with one locked drawer and unlocked cabinet door below. Cabinet door is handed. Specify left or right opening.		
Stryker		Model	Clinical	Non-Clinical
F-D9c		Tru-Fit Overbed Table	*	
		Location: <u>Patient Room</u> Remarks: Overbed Table. Do not spec with drawers or flip surface. Provide w/ u-base. ICU/PACU – Split-Top w/ Vanity #3150-000-300 Other – Split-Top w/o Vanity #3150-000-200		

MedViron		Model	Clinical	Non-Clinical
F-D9d		Guardian Bassinet	*	
		Location: <u>Patient Room</u> Remarks:		
Kimball		Model	Clinical	Non-Clinical
F-D9e		Aidin	*	
		Location: <u>Infusion</u> Remarks: Tops available in soft rectangle or D-shape; top materials include ¾" thick TFL/HPL w/ matching 2mm rim, or 1" thick 3DL; optional spill groove with cup holder is available on 3DL tops; pneumatic height adjustment on base is 28.5" – 44.25"; two locking / two non-locking white with grey, dual wheel casters; platinum metallic finish on base with textured aluminum column		

E. SEATING

In order to create and maintain a consistent brand and allow appropriate maintenance at NYU Langone Health spaces, specific furniture and accessory items are used. The list below will give the A/E Team a sense of the typical seating used at NYU Langone facilities. It is the Architect's responsibility to select items that are code compliant and appropriate for the capital project based on the type of space and end-user needs. The Architect and Interior Designer shall consider specifying existing building-specific standards provided they are in line with these Design Guidelines. Architects shall coordinate with the RED+F Project Manager and the Design Studio to finalize seating selections. The images shown are for illustrative purposes only and may not be a reflection of a project's final specification. Please note the following requirements as they pertain to seating:

- All task seating selections must allow for ergonomic adjustments, such as adjustable arm heights, seat depths, seat heights, etc.
- Provide seating selections with hard casters for carpeted areas and soft casters for hard floor surface areas.
- 20% of all seating in Waiting Areas must meet Bariatric seating requirements.
- Mesh and upholstery shall be PVC-free. Consider silica as an alternative upholstery fabric.
- Foam shall be formaldehyde-free.
- Use manufacturer's graded in upholstery for items identified as Cost-saving Alternatives.



Cost-saving Alternatives:





The RED+F PM will advise the A/E Design Team if items identified as Cost-saving Alternatives shall be allowed on their project. There may be risks associated with using such items, including the need to repair or replace them more often, but it has been determined they are within acceptable range for use on certain NYU Langone Health projects.

The product specifications included in this subsection are organized by type as follows:



- F-E1 Conference Seating
- F-E2 Task Chairs
- F-E3 Task Stools
- F-E4 Private Office Guest Seating
- F-E5 Stacking / Nesting Seating
- F-E6 Café / Staff Lounge Seating
- F-E7 Waiting Area Lounge Seating
- F-E8 Waiting Area Tandem Seating with Power / USB Outlets
- F-E9 Waiting Area Tandem Seating without Power
- F-E10 Bench Seating
- F-E11 Banquet Seating
- F-E12 Clinical Guest Seating
- F-E13 Specialty Seating
- F-E14 Recliners
- F-E15 Inpatient Sleepers



F-E1 CONFERENCE SEATING				
Keilhauer		Model	Clinical	Non-Clinical
F-E1a		Vanilla #5462		*
		Location: <u>Conference Rooms</u> (NYU Langone Health Preferred) Remarks: Mid back, slim line, polished aluminum arm and base. Use sloped arm version. Coordinate arm heights with table heights to avoid conflict. 300 lb. capacity		
Keilhauer		Model	Clinical	Non-Clinical
F-E1b		6C		*
		Location: <u>Conference Rooms</u> Remarks: Coordinate arm heights with table heights to avoid conflict. 300 lb. capacity		
F-E1 CONFERENCE SEATING (COST-SAVING ALTERNATIVES)				
Keilhauer		Model	Clinical	Non-Clinical
F-E1c		Vanilla #5531		*
		Location: <u>Conference Rooms</u> Remarks: Low back, border with piping, black urethane arm. Use sloped arm version when not using urethane arm cap. Coordinate arm heights with table heights to avoid conflict. 300 lb. capacity		
VIA Seating		Model	Clinical	Non-Clinical
F-E1d		Proform 171		*
		Location: <u>Conference Rooms</u> Remarks: Mid back w/ 97A contemporary cantilever arm. Coordinate arm heights with table heights to avoid conflict. 300 lb. capacity		



F-E2 TASK CHAIRS				
Herman Miller		Model	Clinical	Non-Clinical
F-E2a		Aeron		*
		Location: <u>Private Office / Workstation</u> Remarks: Typical model #AER1B23DW-ALP. Typical model includes Aeron B size standard height range chair with adjustable tilt lumbar and seat angle and non-upholstered fully adjustable arms. 300 lb. capacity (size A) and 350 lb. capacity (sizes B and C)		
Steelcase		Model	Clinical	Non-Clinical
F-E2b		Gesture*	*	*
		Location: <u>Private Office / Workstation / Clinical Workstation</u> Remarks: Typical model #442A30. Specify w/ upholstery, shell back, adjustable seat depth, 360-degree arms, 5" pneumatic seat height adjustment. Fully upholstered back required at clinical workstations. 400 lb. capacity		
Steelcase		Model	Clinical	Non-Clinical
F-E2c		Leap*		*
		Location: <u>Private Office / Workstation</u> Remarks: Typical model #46216179. Specify w/ height, width, pivot, depth adjustable arms; lumbar option; 5" pneumatic seat height adjustment. 400 lb. capacity		
Steelcase		Model	Clinical	Non-Clinical
F-E2d		Think*		*
		Location: <u>Private Office / Open Workstation / Reading Room / Dry Laboratory Workstation</u> Remarks: Typical model #465A000. Provide with height, width, pivot, depth adjustable arms, adjustable seat depth and sliding lumbar support. Fully upholstered option preferred for management offices. Mesh back option preferred for all other locations. 400 lb. capacity		





Steelcase		Model	Clinical	Non-Clinical
F-E2e		Amia*	*	*
		Location: <i>Private Office / Open Workstation / Clinical Workstation / Wet Laboratory Workstation</i> Remarks: Typical model #4821410U. Provide with height, width, pivot, depth adjustable arms; live lumbar feature and 5” high seat range. Fully upholstered back required at clinical and laboratory workstations. 400 lb. capacity		
Haworth		Model	Clinical	Non-Clinical
F-E2f		Zody*		*
		Location: <i>Private office / Open Workstation</i> Remarks: Typical model # SZT-20-721MA5 Provide with PAL back system, 4D arms, tension tilt control, multi-position backstop. Model above is standard with plastic base and hard casters. 250 lb. capacity		
F-E2 TASK CHAIRS (COST-SAVING ALTERNATIVES)				
AllSeating		Model	Clinical	Non-Clinical
F-E2g		YouToo		*
		Location: <i>Private office / Open Workstation</i> Remarks: Typical model #85040-4D-BKN-21R-SS-BHA-AWK-LH-KD-F-PBLA-AS. Provide medium seat, 4D arms, mid back, seat slider, adjustable width bracket knob, back height adjustment, standard lumbar. Highback version “You” shall be used only when deemed necessary as part of an ergonomic assessment / request. 350 lb. capacity		
Humanscale		Model	Clinical	Non-Clinical
F-E2h		Liberty*		*
		Location: <i>Private office / Open Workstation</i> Remarks: Typical model #L111BM10FT10. 300 lb. capacity		



SitOnIt		Model	Clinical	Non-Clinical
F-E2i		Vectra		*
		Location: <i>Private office / Open Workstation</i> Remarks: Typical model #1073-BK2-MB-L/E3-AR9. Provide with high back, 8 way arms, graphite frame, standard cylinder, advanced synchro mechanism with seat depth adjustment. 300 lb. capacity		
Notes: 1. End-user trial required prior to specification of task chair and/or headrest. 2. Caster selection must be coordinated with floor finish at chair location. 3. * next to model name indicates availability of headrest.				





F-E3 TASK STOOLS				
Keilhauer		Model	Clinical	Non-Clinical
F-E3a		Sky	*	
		Location: <i>Clinical Use</i> Remarks: Typical model #2ST312. Available with or without back. If provided, back shall be fully upholstered. Provide w/ alum. base, hand activated upholstered seat, medium seat height (17.5" – 25.25"). Coordinate use with height adjustability range. Use siliform for Clean Room or Pharmacy drug mixing. Breaking mechanism optional (can be retrofitted on site). 273 lb. capacity		
HAG		Model	Clinical	Non-Clinical
F-E3b		Capisco	*	*
		Location: <i>Clinical Use / Wet Lab Benching / Wet Lab Workstations</i> Remarks: Back and seat shall be fully upholstered. Provide w/ alum. base and hand activated seat. Available with/without removable footring and in a range of heights. 250 lb. capacity. Confirm model #s w/ RED+F.		





Steelcase		Model	Clinical	Non-Clinical
F-E3c		Amia	*	*
		Location: <i>Wet Laboratory Benching</i> Remarks: Typical model #4827410U. Provide with height, width, pivot, depth adjustable arms (if requested by user); live lumbar feature and 5" high seat range. Seat height adjustment between 23" – 31". Fully upholstered back version only. For Laboratory Workstations, specify coordinating Amia chair with fully upholstered back. 400 lb. capacity		
Steelcase		Model	Clinical	Non-Clinical
F-E3d		Think		*
		Location: <i>Dry Laboratory Benching</i> Remarks: Typical model #465B000. Provide with height, width, pivot, depth adjustable arms, adjustable seat depth and sliding lumbar support. Seat height adjustment between 22.5" – 32". Fully upholstered back version only. For Dry Laboratory Workstations, specify coordinating Think chair with fully upholstered back. 400 lb. capacity		





F-E4 PRIVATE OFFICE GUEST SEATING				
Geiger		Model	Clinical	Non-Clinical
F-E4a		Bumper		*
		Location: <i>Private Office</i> Remarks: 300 lb. capacity		
Arcadia		Model	Clinical	Non-Clinical
F-E4b		Nios Guest		*
		Location: <i>Private Office</i> Remarks: 300 lb. capacity; no wallsaver		

Steelcase		Model	Clinical	Non-Clinical
F-E4c		Bindu		*
		Location: <i>Private Office</i> Remarks: 300 lb. capacity		
Bernhardt		Model	Clinical	Non-Clinical
F-E4d		Helium		*
		Location: <i>Private Office</i> Remarks: 275 lb. capacity		
Krug		Model	Clinical	Non-Clinical
F-E4e		Karma		*
		Location: <i>Private Office</i> Remarks: 500 lb. capacity		
Steelcase		Model	Clinical	Non-Clinical
F-E4f		Wrapp		*
		Location: <i>Private Office / Collaboration Areas</i> Remarks: 275 lb. capacity		
Teknion		Model	Clinical	Non-Clinical
F-E4g		Sitara		*
		Location: <i>Private Office</i> Remarks: 300 lb. capacity with wall saver		





F-E4 PRIVATE OFFICE GUEST SEATING (COST-SAVING ALTERNATIVES)				
Steelcase		Model	Clinical	Non-Clinical
F-E4h		Collaboration		*
		Location: <u>Private Office</u> Remarks: 275 lb. capacity		
SitOnIt		Model	Clinical	Non-Clinical
F-E4i		Cora		*
		Location: <u>Private Office</u> Remarks: Wall saver; midsize 26” and bariatric 30” options available. Standard capacity is 500 lb. Midsize version will provide 600 lb. capacity. Bariatric option will provide 750 lb. capacity.		
Source International		Model	Clinical	Non-Clinical
F-E4j		Font		*
		Location: <u>Private Office</u> Remarks: Provide with Script arms. 500 lb. capacity		
F-E5 STACKING / NESTING SEATING				
Kusch		Model	Clinical	Non-Clinical
F-E5a		Sevilla SEV4		*
		Location: <u>Conference Room / Training Room / Multipurpose Room / Seminar</u> Remarks: Stacking armchair with bright chrome frame and arms. Standard with plastic glides. 300 lb. capacity		

Herman Miller		Model	Clinical	Non-Clinical
F-E5b		Caper		*
		Location: <u>Conference Room / Training Room / Multipurpose Room / Reading Room / Seminar</u> Remarks: Stacks 6 on the floor, 15 on caper cart. Available with casters. 300 lb. capacity		
SitOnIt		Model	Clinical	Non-Clinical
F-E5c		Movi Nester		*
		Location: <u>Conference Room / Training Room / Multipurpose Room / Seminar</u> Remarks: 300 lb. capacity; Available with and without arms, casters or glides.		
Allermuir		Model	Clinical	Non-Clinical
F-E5d		Trillipse		*
		Location: <u>Conference Room / Training Room / Multipurpose Room / Seminar</u> Remarks: Stacks 5 on the floor or dolly. Comes with casters. 253 lb. capacity		
F-E5 STACKING / NESTING SEATING (COST-SAVING ALTERNATIVES)				
AllSeating		Model	Clinical	Non-Clinical
F-E5e		Tuck Stacker		*
		Location: <u>Conference Room / Training Room / Multipurpose Room / Seminar</u> Remarks: Stacking chair available with or without arms, upholstered and non-upholstered. 350 lb. capacity		
SitOnIt		Model	Clinical	Non-Clinical
F-E5f		On Call		*
		Location: <u>Conference Room / Training Room / Multipurpose Room / Seminar</u> Remarks: Stacks 8 on the floor, 20-25 on optional cart. 250 lb. capacity		

Andreu World		Model	Clinical	Non-Clinical
F-E5g		Flex		*
		Location: <u>Conference Room / Training Room / Multipurpose Room / Seminar</u> Remarks: Molded plastic stacking chair. Stacks 10 on the floor or 15 on an optional dolly. 350 lb. capacity		
F-E6 CAFÉ / STAFF LOUNGE / WAITING AREA SEATING				
Andreu World		Model	Clinical	Non-Clinical
F-E6a		Flex Chair		*
		Location: <u>Café / Cafeteria / Waiting Area</u> Remarks: Provide with wood legs. 350 lb. capacity		
Kusch		Model	Clinical	Non-Clinical
F-E6b		8500 Ona Plaza		*
		Location: <u>Staff Lounge</u> Remarks: Available with arm pads. 242.5 lb. capacity		
Stylex		Model	Clinical	Non-Clinical
F-E6c		Verve Chair		*
		Location: <u>Café / Cafeteria / Staff Lounge</u> Remarks: Provide w/ 4 legs only. 350 lb. capacity		
Global Furniture Group		Model	Clinical	Non-Clinical
F-E6d		Caprice		*
		Location: <u>Staff Lounge</u> Remarks: 300 lb. capacity		

Coalesse		Model	Clinical	Non-Clinical
F-E6e		Enea Lottus (plastic)		*
		Location: <u>Staff Lounge</u> Remarks: Provide chair w/ 4 legs only. 275 lb. capacity		
F-E6 CAFÉ / STAFF LOUNGE / WAITING AREA SEATING (COST-SAVING ALTERNATIVES)				
SitOnIt		Model	Clinical	Non-Clinical
F-E6f		Inflex Chair		*
		Location: <u>Staff Lounge</u> Remarks: Chair stacks 5 on the floor, 8-12 on optional cart. 300 lb. capacity		
AllSeating		Model	Clinical	Non-Clinical
F-E6g		Tuck (4-Leg)		*
		Location: <u>Staff Lounge</u> Remarks: Provide with wall saver. 350 lb. capacity		
Dauphin		Model	Clinical	Non-Clinical
F-E6h		Cempa (4 post)		*
		Location: <u>Staff Lounge</u> Remarks: Provide with wall saver. 300 lb. capacity		



F-E7 WAITING AREA LOUNGE SEATING				
Keilhauer		Model	Clinical	Non-Clinical
F-E7a		KM Classic Low Arm	*	*
		Location: <u>Waiting Area</u> Remarks: 273 lb. capacity with special order w/ MSQ.		
Carolina		Model	Clinical	Non-Clinical
F-E7b		Rule of Three	*	*
		Location: <u>Waiting Area</u> Remarks: Standard option has a 400 lb. capacity. Bariatric option has a 500 lb. capacity.		
HBF		Model	Clinical	Non-Clinical
F-E7c		Salon		*
		Location: <u>Waiting Area</u> Remarks: 350 lb. capacity		
Keilhauer		Model	Clinical	Non-Clinical
F-E7d		Doon	*	*
		Location: <u>Waiting Area</u> Remarks: 500 lb. capacity with special order w/ MSQ.		
Keilhauer		Model	Clinical	Non-Clinical
F-E7e		KM Tufted Tuxedo	*	*
		Location: <u>Waiting Area</u> Remarks: 250 lb. capacity		

KI		Model	Clinical	Non-Clinical
F-E7f		Affina	*	*
		Location: <u>Waiting Area</u> Remarks: Available with wood arm caps. 300 lb. capacity		
Arcadia		Model	Clinical	Non-Clinical
F-E7g		Leaf Lounge	*	*
		Location: <u>Waiting Area</u> Remarks: 500 lb. capacity. Available with modular tables.		
Coalesse		Model	Clinical	Non-Clinical
F-E7h		Joel	*	*
		Location: <u>Waiting Area</u> Remarks: 253 lb. capacity		
Bernhardt		Model	Clinical	Non-Clinical
F-E7i		Glasgow	*	*
		Location: <u>Waiting Area</u> Remarks: 275 lb. capacity		
AllSeating		Model	Clinical	Non-Clinical
F-E7j		Ayles		*
		Location: <u>Waiting Area</u> Remarks: Midback, cone mechanism, lounge base. 350 lb. capacity		



Steelcase		Model	Clinical	Non-Clinical
F-E7k		Leela	*	*
		Location: <u>Waiting Area</u> Remarks: Standard 300 lb. capacity. Bariatric models provide 500 lb. capacity per seat.		
F-E7 WAITING AREA LOUNGE SEATING (COST-SAVING ALTERNATIVES)				
Arcadia		Model	Clinical	Non-Clinical
F-E7l		Uptown Social	*	*
		Location: <u>Waiting Area</u> Remarks: 350 lb. capacity with special order		
Global Furniture Group		Model	Clinical	Non-Clinical
F-E7m		Citi Square		*
		Location: <u>Waiting Area</u> Remarks: 300 lb. capacity		
Kimball		Model	Clinical	Non-Clinical
F-E7n		Boyd	*	*
		Location: <u>Waiting Area</u> Remarks: 300 lb. capacity		

Arcadia		Model	Clinical	Non-Clinical
F-E70		Domo Lounge	*	*
		Location: <u>Waiting Area</u> Remarks: 1,000 lb. capacity for sofa, 750 lb. capacity for settee, 350 lb. capacity for lounge. Available with swivel base.		

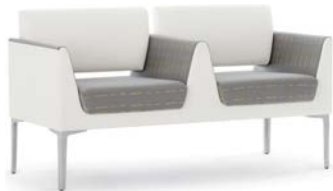

- Notes:
1. Loveseat / sofa versions available with most lounge chairs.
 2. 20% of all seating in Waiting Areas must meet Bariatric seating requirements.
 3. Where the patient population is likely to have either mobility issues (i.e. orthopedics, rheumatology, etc.) or where stroller use is anticipated:
 - a. Provide ADA-compliant clear floor space in place of 10% of the total seating within the seating area.
 - b. Provide convenience electrical outlets adjacent to the clear floor space.

F-E8 WAITING AREA TANDEM SEATING WITH POWER/USB OUTLETS				
Krug		Model	Clinical	Non-Clinical
F-E8a		Faeron	*	*
		Location: <u>Waiting Area</u> Remarks: Bariatric model available. Available with power/USB outlets. 500 lb. capacity per 21" and 24" seat. 750 lb. capacity per 30" and 44" seat		
Carolina		Model	Clinical	Non-Clinical
F-E8b		Modern Amenity	*	*
		Location: <u>Waiting Area</u> Remarks: Spec with polyurethane arm caps. Available with power/USB outlets. 500 lb. capacity		
Arcadia		Model	Clinical	Non-Clinical
F-E8c		Savina	*	*
		Location: <u>Waiting Area</u> Remarks: Available with power/USB outlets. 350 lb. capacity for lounge, 750 lb. capacity for love seat		



F-E8 WAITING AREA TANDEM SEATING WITH POWER/USB OUTLETS (COST-SAVING ALTERNATIVES)				
Arcadia		Model	Clinical	Non-Clinical
F-E8d		Domo Modular	*	*
		Location: <u>Waiting Area</u> Remarks: Available with power/USB outlets. 350 lb. capacity for lounge, 750 lb. capacity for settee, 1,000 lb. capacity for sofa		
Notes: 1. 20% of all seating in Waiting Areas must meet Bariatric seating requirements. 2. Where the patient population is likely to have either mobility issues (i.e. orthopedics, rheumatology, etc.) or where stroller use is anticipated: <ol style="list-style-type: none"> a. Provide ADA-compliant clear floor space in place of 10% of the total seating within the seating area. b. Provide convenience electrical outlets adjacent to the clear floor space. 				

F-E9 WAITING AREA TANDEM SEATING WITHOUT POWER				
KI		Model	Clinical	Non-Clinical
F-E9a		Affina	*	*
		Location: <u>Waiting Area</u> Remarks: Spec with polyurethane arm caps. For use in tight waiting areas that require modular seating. Bariatric model available. 300 lb. capacity per seat		
Gunlocke		Model	Clinical	Non-Clinical
F-E9b		Molti	*	*
		Location: <u>Waiting Area</u> Remarks: For use in tight waiting areas that require modular seating. Bariatric model available. 300 lb. capacity		



F-E9 WAITING AREA TANDEM SEATING WITHOUT POWER (COST-SAVING ALTERNATIVES)				
Ideon		Model	Clinical	Non-Clinical
F-E9c		Aviera	*	*
		Location: <u>Waiting Area</u> Remarks: Spec with polyurethane arm caps. 500 lb. capacity per seat. 750 lb. capacity per seat on bariatric models.		
Notes: 1. 20% of all seating in Waiting Areas must meet Bariatric seating requirements. 2. Where the patient population is likely to have either mobility issues (i.e. orthopedics, rheumatology, etc.) or where stroller use is anticipated: <ol style="list-style-type: none"> a. Provide ADA-compliant clear floor space in place of 10% of the total seating within the seating area. b. Provide convenience electrical outlets adjacent to the clear floor space. 				



F-E10 BENCH SEATING				
Knoll		Model	Clinical	Non-Clinical
F-E10a		Florence		*
		Location: <u>Public Lobby</u> (NYU Langone Health Standard) Remarks: 350 lb. capacity		
Coalesse		Model	Clinical	Non-Clinical
F-E10b		Millbrae		*
		Location: <u>Public Lobby / Waiting Area</u> Remarks: 253 lb. capacity		
Coalesse		Model	Clinical	Non-Clinical
F-E10c		Await		*
		Location: <u>Public Lobby / Waiting Area</u> Remarks: 253 lb. capacity		

Beachley		Model	Clinical	Non-Clinical
F-E10d		NYULH Custom Bench w/ Arm		*
		Location: <i>Public Lobby / Waiting Area</i> Remarks: 500 lb. capacity		
F-E10 BENCH SEATING (COST-SAVING ALTERNATIVES)				
Global Furniture Group		Model	Clinical	Non-Clinical
F-E10e		Ballara		*
		Location: <i>Public Lobby / Waiting Area</i> Remarks: 300 lb. capacity per seat		
Notes:				
<ol style="list-style-type: none"> 20% of all seating in Waiting Areas must meet Bariatric seating requirements. Where the patient population is likely to have either mobility issues (i.e. orthopedics, rheumatology, etc.) or where stroller use is anticipated: <ol style="list-style-type: none"> Provide ADA-compliant clear floor space in place of 10% of the total seating within the seating area. Provide convenience electrical outlets adjacent to the clear floor space. 				





F-E11 BANQUET SEATING				
Beachley		Model	Clinical	Non-Clinical
F-E11a		Slab Two	*	*
		Location: <i>Café / Cafeteria / Staff Lounge / Waiting Areas / Administrative Spaces</i> Remarks: 225 lb. capacity per seat		
F-E11 BANQUET SEATING (COST-SAVING ALTERNATIVES)				
Beachley		Model	Clinical	Non-Clinical
F-E11b		Constants	*	*
		Location: <i>Café / Cafeteria / Staff Lounge / Waiting Areas / Administrative Spaces</i> Remarks: 165 lb. capacity per seat		

Keilhauer		Model	Clinical	Non-Clinical
F-E11c		Parlez	*	*
		Location: <u>Waiting Areas / Administrative Spaces</u> Remarks: 273 lb. capacity per seat		
Notes: 1. 20% of all seating in Waiting Areas must meet Bariatric seating requirements. 2. Where the patient population is likely to have either mobility issues (i.e. orthopedics, rheumatology, etc.) or where stroller use is anticipated: a. Provide ADA-compliant clear floor space in place of 10% of the total seating within the seating area. b. Provide convenience electrical outlets adjacent to the clear floor space.				

F-E12 CLINICAL GUEST SEATING				
Krug		Model	Clinical	Non-Clinical
F-E12a		Karma	*	
		Location: <u>Exam Room</u> Remarks: 500 lb. capacity. Provide with wall saver. Bariatric option available.		
Source International		Model	Clinical	Non-Clinical
F-E12b		Font	*	
		Location: <u>Exam Room</u> Remarks: 500 lb. capacity. Provide with wall saver and Script arms. Bariatric option available.		
Global Furniture Group		Model	Clinical	Non-Clinical
F-E12c		Janna	*	
		Location: <u>Exam Room</u> Remarks: Can be wall hung with optional wall mount. 500 lb. capacity.		

F-E12 CLINICAL GUEST SEATING (COST-SAVING ALTERNATIVES)				
SitOnIt		Model	Clinical	Non-Clinical
F-E12d		Freelance	*	
		Location: <u>Exam Room</u> Remarks: Spec upholstered version. Standard capacity is 300 lb. Heavy duty 24/7 version will provide 350 lb. capacity. Bariatric option will provide 500 lb. (30") or 1,000 lb. (42") capacity.		
Encore		Model	Clinical	Non-Clinical
F-E12e		Mozie	*	
		Location: <u>Exam Room</u> Remarks: 400 lb. capacity. Available in bariatric and caster options. Provide with wall saver.		
AllSeating		Model	Clinical	Non-Clinical
F-E12f		Tuck 4-Leg	*	
		Location: <u>Exam Room</u> Remarks: 350 lb. capacity. Available with or without arms. Provide with wall saver.		

F-E13 SPECIALTY SEATING				
Krug		Model	Clinical	Non-Clinical
F-E13a		Jordan Patient	*	
		Location: <u>Patient Room</u> Remarks: 500 lb. capacity for 21" and 24" seats. 750 lb. capacity for 30" seat		

Spec Furniture		Model	Clinical	Non-Clinical
F-E13b		Snowball 2	*	
		Location: <u>Phlebotomy</u> Remarks: Standard option #1854-PH-W20 (500 lb. capacity); Bariatric option #1853-PH-W20 (500 lb. capacity).		
Global Furniture Group		Model	Clinical	Non-Clinical
F-E13c		Bakhita #6751	*	
		Location: <u>MRI (Zone I)</u> Remarks: Non Ferrous stackable side chair with polymer seat and back; 300 lb. capacity; Provide (2) chairs per MRI scan room		
Coalesse		Model	Clinical	Non-Clinical
F-E13d		Massaud Work Lounge		*
		Location: <u>Lactation/ Wellness Room</u> Remarks: Provide PVC-free upholstery. Provide with swivel tablet surface; side table not required; coordinating Massaud ottoman available; electric required at wall adjacent to chair. 253 lb. capacity		
F-E13 SPECIALTY SEATING (COST-SAVING ALTERNATIVES)				
Krug		Model	Clinical	Non-Clinical
F-E13e		Faeron Easy Access Chair	*	
		Location: <u>Waiting Area</u> Remarks: Hip Chair model # FAE2-HP21OUC. 21” wide. 500 lb. capacity. Provide with wallsaver.		
Krug		Model	Clinical	Non-Clinical
F-E13f		Faeron	*	
		Location: <u>Patient Room</u> Remarks: Provide with wallsaver. 500 lb. capacity for standard patient chair. 750 lb. capacity for “plus” patient chair		

Krug		Model	Clinical	Non-Clinical
F-E13g		Faeron Lounge (Highback)		*
		Location: <u>Lactation Room / Wellness Room</u> Remarks: Provide w/ closed wood arms, no caps and matching side table. 500 lb. capacity for “one seat” and “one seat wide” chair. 750 lb. capacity for “one seat plus” and “one seat plus wide” chair		

F-E14 RECLINERS				
IOA		Model	Clinical	Non-Clinical
F-E14a		Kangaroo	*	
		Location: <u>Mother-Baby Units / NICU</u> Remarks: Bariatric. Add foley bag holder accessory and central locking casters. Confirm model #s w/ RED+F. 500 lb. capacity		
Steelcase Health		Model	Clinical	Non-Clinical
F-E14b		Empath	*	
		Location: <u>Various</u> Remarks: Provide w/ central locking casters. Confirm model #s w/ RED+F. 300 lb. capacity		
Krug		Model	Clinical	Non-Clinical
F-E14c		Jordan	*	
		Location: <u>Various</u> Remarks: Provide w/ central locking casters. Confirm model #s w/ RED+F. 350 lb. capacity		
IOA		Model	Clinical	Non-Clinical
F-E14d		Suspend Recliner	*	
		Location: <u>Various</u> Remarks: Provide w/ central locking casters. Confirm model #s w/ RED+F. 500 lb. capacity		

Carolina		Model	Clinical	Non-Clinical
F-E14e		Orchestra Recliner #1408-R-OB	*	
		Location: <i>Various (Bariatric)</i> Remarks: Provide w/ larger middle footrest to close gap, padded push bar (H1Z), central locking casters (CLC), and pull out foot tray (E1K). 500 lb. capacity; Confirm model #s w/ RED+F.		

F-E15 INPATIENT SLEEPERS

IOA		Model	Clinical	Non-Clinical
-----	--	-------	----------	--------------

F-E15a		88 Sleeper Chair	*	
		Location: <i>Patient Room</i> Remarks: Available as single chair, double size or loveseat. Provide w/ central locking casters. 500 lb. capacity		

IOA		Model	Clinical	Non-Clinical
-----	--	-------	----------	--------------

F-E15b		Suspend Sleeper	*	
		Location: <i>Patient Room</i> Remarks: Footrest can support up to 300 lbs. Provide w/ central locking casters. 500 lb. capacity		

IOA		Model	Clinical	Non-Clinical
-----	--	-------	----------	--------------

F-E15c		504 Sideline Sofa	*	
		Location: <i>Patient Room</i> Remarks: Provide with Arm Style #507 – Stay and central locking casters. 1,000 lb. capacity		

F-E15 INPATIENT SLEEPERS (COST-SAVING ALTERNATIVES)

Global Furniture Group		Model	Clinical	Non-Clinical
------------------------	--	-------	----------	--------------

F-E15d		Sleep Eez	*	
		Location: <i>Patient Room</i> Remarks: Provide w/ central locking casters. 300 lb. capacity		

Weiland		Model	Clinical	Non-Clinical
F-E15e		Sleep Too	*	
		Location: <i>Patient Room</i> Remarks: 750 lb. capacity (without center table). 250 b. capacity per seat (with center table).		

F. STORAGE

In order to create and maintain a consistent brand and allow appropriate maintenance at NYU Langone Health spaces, specific furniture and accessory items are used. The list below will give the A/E Team a sense of the typical storage solutions used at NYU Langone facilities. It is the Architect’s responsibility to select items that are code compliant and appropriate for the capital project based on the type of space and end-user needs. The Architect and Interior Designer shall consider specifying existing building-specific standards provided they are in line with these Design Guidelines. Architects shall coordinate with the RED+F Project Manager and the Design Studio to finalize fixture selections. The images shown are for illustrative purposes only and may not be a reflection of a project’s final specification. Please note the following requirements as they pertain to storage:

- All substrate shall be formaldehyde free.

Please note that it is our mission to decrease the use of paper and to that end please confirm what documents or products must be stored on site when selecting storage fixtures. RED+F can provide assistance in calculating and selecting the proper storage solution.





Cost-saving Alternatives:

The RED+F PM will advise the A/E Design Team if items identified as Cost-saving Alternatives shall be allowed on their project. There may be risks associated with using such items, including the need to repair or replace them more often, but it has been determined they are within acceptable range for use on certain NYU Langone Health projects.

The product specifications included in this subsection are organized by type as follows:

- F-F1 Closed Storage
- F-F2 Open Shelving
- F-F3 Open Storage
- F-F4 Mobile Storage Carts
- F-F5 Lockers
- F-F6 Locker Hardware

F-F1 CLOSED STORAGE				
Herman Miller		Model	Clinical	Non-Clinical
F-F1a		Canvas		*
		Location: <i>As required</i> Remarks: Metal Storage Units.		

Steelcase		Model	Clinical	Non-Clinical
F-F1b		Universal		*
		Location: <i>As required</i> Remarks: Pedestals, Lateral Files, Cabinets, Bookcases, Towers and Overhead Storage available.		
F-F1 CLOSED STORAGE (COST-SAVING ALTERNATIVES)				
Uhuru Design		Model	Clinical	Non-Clinical
F-F1c		Totem Slim Rolling Pedestal		*
		Location: <i>As required</i> Remarks:		
Herman Miller		Model	Clinical	Non-Clinical
F-F1d		Meridian		*
		Location: <i>As required</i> Remarks: Storage Units.		
Global Furniture Group		Model	Clinical	Non-Clinical
F-F1e		9300 Series		*
		Location: <i>Back of House / Storage Rooms</i> Remarks: Storage Units. Consult w/ RED+F for Statement of the Line Guideline.		



F-F2 OPEN SHELVING				
MadGirl		Model	Clinical	Non-Clinical
F-F2a		Arche+Type Wall Standard		*
		Location: <i>Private Office / Open Work Area</i> Remarks: Wall mounted shelving system with metal or laminate shelves; clear anodized alum. finish		





F-F3 OPEN STORAGE				
Nexel Industries		Model	Clinical	Non-Clinical
F-F3a		Varies	*	*
		Location: <i>Storage Rooms</i> Remarks: Wire Shelving. Non-caster models available. Solid shelf at the bottom and covers for clinical locations.		



F-F3 OPEN STORAGE (COST-SAVING ALTERNATIVES)				
Metro Shelving		Model	Clinical	Non-Clinical
F-F3b		Varies	*	*
		Location: <i>Storage Rooms</i> Remarks: Wire Shelving. Non-caster models available. Solid shelf at the bottom and covers for clinical locations.		

F-F4 MOBILE STORAGE CARTS				
Herman Miller		Model	Clinical	Non-Clinical
F-F4a		C-Locker	*	
		Location: <i>As required</i> Remarks: Procedure / Supply Cart with tambour door		



Herman Miller		Model	Clinical	Non-Clinical
F-F4b		Varies	*	
		Location: <i>As required</i> Remarks: Procedure / Supply Cart		

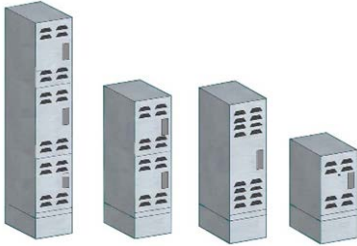

F-F5 LOCKERS				
New England Wood Co.		Model	Clinical	Non-Clinical
F-F5a		1-Tier HPL Lockers	*	
		Location: <i>Gown Waiting / Other Patient Areas</i> Remarks: A/E Team to confirm room size and locker configuration, size (12”w x 24”d x 76”h incl. 6”h closed base, typ), quantity and locking mechanism (Zephyr mechanical push button lock #6510 preferred) w/ end user.		
New England Wood Co.		Model	Clinical	Non-Clinical
F-F5b		HPL Z-Lockers	*	
		Location: <i>Gown Waiting / Other Patient Areas</i> Remarks: A/E Team to confirm room size and locker configuration (single or double), size (width varies x 24”d x 76”h incl. 6”h closed base, typ), quantity and locking mechanism (Zephyr mechanical push button lock #6510 preferred) w/ end user.		
New England Wood Co.		Model	Clinical	Non-Clinical
F-F5c		Personal HPL Lockers	*	
		Location: <i>Gown Waiting / Other Patient Areas</i> Remarks: A/E Team to confirm room size and locker configuration, size, quantity and locking mechanism (Zephyr mechanical push button lock #6510 preferred) w/ end user. HPL finished top optional. 1-Tier (short): 12”w x 18”d x 29”h, typ. 1-Tier (tall): 12”w x 18”d x 39”h, typ. 2-Tier: 12”w x 18”d x 39”h, typ. 3-Tier: 12”w x 18”d x 56”h, typ.		

Hallowell or Perfix		Model	Clinical	Non-Clinical
F-F5d		1-Tier Steel Lockers	*	*
		Location: <u>Staff Locker Rooms</u> Remarks: A/E Team to confirm room size and locker configuration, size (12”w x 18”d x 78”h incl. 6”h closed base, typ), quantity and locking mechanism (Hollman high security padlock hasp w/ Zephyr padlock #1925 preferred) w/ end user.		
Hallowell or Perfix		Model	Clinical	Non-Clinical
F-F5e		2-Tier Steel Lockers	*	*
		Location: <u>Staff Locker Rooms</u> Remarks: A/E Team to confirm room size and locker configuration, size (12”w x 18”d x 78”h incl. 6”h closed base, typ), quantity and locking mechanism (Hollman high security padlock hasp w/ Zephyr padlock #1925 preferred) w/ end user.		
Hallowell or Perfix		Model	Clinical	Non-Clinical
F-F5f		3-Tier Steel Lockers	*	*
		Location: <u>Staff Locker Rooms</u> Remarks: A/E Team to confirm room size and locker configuration, size (12”w x 18”d x 78”h incl. 6”h closed base, typ), quantity and locking mechanism (Hollman high security padlock hasp w/ Zephyr padlock #1925 preferred) w/ end user.		
Hallowell or Perfix		Model	Clinical	Non-Clinical
F-F5g		2 Person 1-Tier Steel Lockers	*	*
		Location: <u>Staff Locker Rooms</u> Remarks: A/E Team to confirm room size and locker configuration, size (15”w x 18”d x 78”h incl. 6”h closed base, typ), quantity and locking mechanism (Hollman high security padlock hasp w/ Zephyr padlock #1925 preferred) w/ end user. Closed shoe cubbies at top shall be operable only when corresponding locker below is open.		

Hallowell or Perfix		Model	Clinical	Non-Clinical
F-F5h		Personal Steel Lockers	*	*
		<p>Location: <u>Staff Locker Rooms / Open Staff Areas</u> Remarks: A/E Team to confirm room size and locker configuration, size, quantity and locking mechanism (Hollman high security padlock hasp w/ Zephyr padlock #1925 preferred) w/ end user. HPL finished top optional. 1-Tier (short): 12”w x 18”d x 29”h, typ. 1-Tier (tall): 12”w x 18”d x 39”h, typ. 2-Tier: 12”w x 18”d x 39”h, typ. 3-Tier: 12”w x 18”d x 56”h, typ.</p>		
Herman Miller		Model	Clinical	Non-Clinical
F-F5i		Meridian / Personal Steel Lockers	*	*
		<p>Location: <u>Open Work Areas / Staff Lounge</u> Remarks: A/E Team to confirm room size and locker configuration, size, quantity and locking mechanism (key lock and electronic lock options available) w/ end user. Available w/ 2 lockers per module in 1-high, 2-high or 3-high stacks. Doors are hinged left or right. Each unit comes w/ or w/o laminate top and has 3 base height options or no base option. 1-Tier (2-locker module): 30”w x 20”d x 19-5/8”h, typ. 2-Tier (4-locker module): 30”w x 20”d x 39-1/4”h, typ. 3-Tier (6-locker module): 30”w x 20”d x 58-7/8”h, typ.</p>		
Steelcase		Model	Clinical	Non-Clinical
F-F5j		TS Series		*
		<p>Location: <u>Open Work Areas / Staff Lounge</u> Remarks: A/E Team to confirm room size and locker configuration, size, quantity and locking mechanism (key lock and electronic lock options available) w/ end user. Available as single and double lockers, quad and cubby lockers, multipurpose and mini lockers.</p>		

Hamilton		Model	Clinical	Non-Clinical
F-F5k		Custom		*
		Location: <i>Open Work Areas / Staff Lounge</i> Remarks: A/E Team to confirm room size and locker configuration, size, and quantity w/ end user. Use with lock F-F6b.		
Notes: <ol style="list-style-type: none"> 1. All locker base shall be integral, closed type. Do not provide toe kick, unless noted otherwise. 2. Locker base height to coordinate with adjacent room base. 3. Room base to be applied over HPL locker base, unless noted otherwise. Heights to match. 4. HPL lockers shall have formaldehyde-free substrate. 5. If no drywall soffit in clinical spaces, provide sloped top (adds 6" in height). 6. For rooms with drywall soffit, coordinate locker height with soffit height. 7. Approved colors for Hallowell or Perfix steel lockers are: Grey, Parchment and Marine Blue. 8. Lockers shall be provided as part of the furniture package and not by the GC. 				

F-F6 LOCKER HARDWARE				
Zephyr		Model	Clinical	Non-Clinical
F-F6a		6510 Mechanical Push Button Lock	*	*
		Location: <i>HPL Lockers</i> Remarks: Vertical design; recessed mounting; A/E Team to confirm lock preferences (hasp vs push button) with end user.		
Keyless		Model	Clinical	Non-Clinical
F-F6b		Keyless1-ADA	*	*
		Location: <i>HPL Lockers</i> Remarks: Vertical design; recessed mounting; with ADA style knob		

Keyless		Model	Clinical	Non-Clinical
F-F6c		KeylessH3-ADA	*	*
		Location: <i>HPL Lockers</i> Remarks: Vertical design; recessed mounting; with ADA style knob; padlock F-E6d required		
Master Lock		Model	Clinical	Non-Clinical
F-F6d		2650	*	*
		Location: <i>HPL / Steel Lockers</i> Remarks: Pushkey turn-free portable padlock (ADA)		
Zephyr		Model	Clinical	Non-Clinical
F-F6e		1925	*	*
		Location: <i>Staff Locker Rooms</i> Remarks: Padlock with supervisory key control		

G. ACCESSORIES

In order to create and maintain a consistent brand and allow appropriate maintenance at NYU Langone Health spaces, specific furniture and accessory items are used. The list below will give the A/E Team a sense of the typical accessories used at NYU Langone facilities to complete a space, increasing its functionality or adding the ergonomic components needed for optimal user comfort. It is the Architect’s responsibility to select items that are code compliant and appropriate for the capital project based on the type of space and end-user needs. The Architect and Interior Designer shall consider specifying existing building-specific standards provided they are in line with these Design Guidelines. Architects shall coordinate with the RED+F Project Manager and the Design Studio to finalize accessory selections. The images shown are for illustrative purposes only and may not be a reflection of a project’s final specification.

Cost-saving Alternatives:

The RED+F PM will advise the A/E Design Team if items identified as Cost-saving Alternatives shall be allowed on their project. There may be risks associated with using such items, including the need to repair or replace them more often, but it has been determined they are within acceptable range for use on certain NYU Langone Health projects.

The product specifications included in this subsection are organized by type as follows:

- F-G1 Chart Holders
- F-G2 Drawer Storage Units
- F-G3 Task Lighting
- F-G4 Decorative Lighting
- F-G5 Undercabinet Lighting
- F-G6 IT Accessories
- F-G7 Glass Marker and Magnet Boards
- F-G8 Tack Boards
- F-G9 Specialty Ergonomic Furniture & Accessories





F-G1 CHART HOLDERS				
Peter Pepper		Model	Clinical	Non-Clinical
F-G1a		4001	*	
		Location: <u>Exam / Patient Room</u> Remarks: Chart Holder. Confirm chart depth prior to specification.		

F-G1 CHART HOLDERS (COST-SAVING ALTERNATIVES)				
Peter Pepper		Model	Clinical	Non-Clinical
F-G1b		13115	*	
		Location: <u>Exam / Patient Room</u> Remarks: Chart Holder. Confirm chart depth prior to specification.		

F-G2 DRAWER STORAGE UNITS				
Doug Mockett		Model	Clinical	Non-Clinical
F-G2a		DWR1-WL-90 or DWR1-90	*	
		Location: <u>Reception/Registration Desks and Billing</u> Remarks: DWR1-WL-90 unit w/ locking lid for registration areas with workstations needing cash drawer. DWR1-90 is the non-locking version. Requires plywood substrate at worksurface for proper installation.		

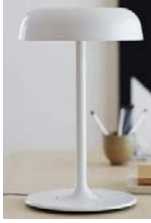

F-G3 TASK LIGHTING				
Humanscale		Model	Clinical	Non-Clinical
F-G3a		Nova Lamp		*
		Location: <u>Private Office / Workstation</u> Remarks: include outlet in base. Provide with technology base.		





F-G4 DECORATIVE LIGHTING				
3-Form Light Art		Model	Clinical	Non-Clinical
F-G4a		LA2 Table Lamp		*
		Location: <u>Private Office</u> Remarks: LED Lamp		



Herman Miller		Model	Clinical	Non-Clinical
F-G4b		Ode Table Lamp		*
		Location: <u>Private Office</u> Remarks:		
Nelson		Model	Clinical	Non-Clinical
F-G4c		Cigar Lotus Table Lamp		*
		Location: <u>Private Office</u> Remarks:		
Artemide Lighting		Model	Clinical	Non-Clinical
F-G4d		Melampo Table		*
		Location: <u>Private Office</u> Remarks: Painted zamac base; painted aluminum stem; silk satin fabric diffuser on a plastic frame.		
Artemide Lighting		Model	Clinical	Non-Clinical
F-G4e		Melampo Floor		*
		Location: <u>Private Office</u> Remarks: Painted zamac base; painted aluminum stem; silk satin fabric diffuser on a plastic frame.		

F-G5 UNDERCABINET LIGHTING				
Herman Miller		Model	Clinical	Non-Clinical
F-G5a		Twist		*
		Location: <u>Private Office / Workstation</u> Remarks: Magnetic installation		

Steelcase		Model	Clinical	Non-Clinical
F-G5b		Underline Shelf Light		*
		Location: <u>Private Office / Workstation</u> Remarks:		

F-G6 IT ACCESSORIES				
Refer to the latest MCIT <i>NYU Langone Health – Hardware Standards</i> .				
Doug Mockett		Model	Clinical	Non-Clinical
F-G6a		PCS98B		*
		Location: <u>Private Office / Workstation</u> Remarks:		
Steelcase		Model	Clinical	Non-Clinical
F-G6b		Powerstrip Plus		*
		Location: <u>Private Office / Workstation</u> Remarks:		
Logiflex		Model	Clinical	Non-Clinical
F-G6c		T19 Table	*	*
		Location: <u>Printer Locations</u> Remarks: Typical model #ML2020TTS19. 20”w x 20”d x 19”h printer stand w/ shelf; confirm finishes w/ RED+F; confirm project needs w/ MCIT		

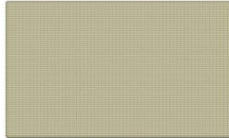
F-G7 GLASS MARKER AND MAGNET BOARDS				
Egan Visual		Model	Clinical	Non-Clinical
F-G7a		GlassWrite MAG (DGM)	*	*
		Location: <i>As required</i> Remarks: Dry-erase magnetic tempered glass marker board; sizes per job requirements; incl. accessories and supplies – Markers, Trays, EganCloth Erasers, EganCloth Caddy (for magnet-compatible glass boards only)		
Clarus		Model	Clinical	Non-Clinical
F-G7b		Glassboard Float	*	*
		Location: <i>As required</i> Remarks: Dry-erase magnetic tempered glass marker board; sizes per job requirements; incl. accessories and supplies – Clarus Markers, Trays, Erasers, Magnets and Caddy (for magnet-compatible glass boards only)		
F-G7 GLASS MARKER AND MAGNET BOARDS (COST-SAVING ALTERNATIVES)				
Bendheim		Model	Clinical	Non-Clinical
F-G7c		QuicKISS	*	*
		Location: <i>As required</i> Remarks: Ready-to-install, quick-ship magnetic dry-erase glass board with built-in wall-mounting hardware; passes 400 lbf (pound-force) impact test; sizes per job requirements; incl. accessories and supplies (i.e. markers, trays, erasers, magnets and caddies for magnet-compatible glass boards only)		
Steelcase		Model	Clinical	Non-Clinical
F-G7d		Edge Series	*	*
		Location: <i>As required</i> Remarks: Whiteboard		

F-G8 TACK BOARDS				
Egan Visual		Model	Clinical	Non-Clinical
F-G8a		MDTB / MDTS	*	*
		Location: <i>As required</i> Remarks: Aluminum Frame Tack board		
F-G8 TACK BOARDS (COST-SAVING ALTERNATIVES)				
CBR		Model	Clinical	Non-Clinical
F-G8b		Mag Tack	*	*
		Location: <i>As required</i> Remarks: Tack board; magnetic fabric wrapped panel		
Forbo		Model	Clinical	Non-Clinical
F-G8c		Bulletin Board	*	*
		Location: <i>As required</i> Remarks: All-natural pin board material; available as framed, surface mounted (i.e. on furniture) or wall applied; non-magnetic		

F-G9 SPECIALTY ERGONOMIC FURNITURE & ACCESSORIES				
Humanscale		Model	Clinical	Non-Clinical
F-G9a		M8.1 / M81BTSBHB	*	*
		Location: <i>Private Office / Workstation</i> Remarks: Monitor Arm		
Humanscale		Model	Clinical	Non-Clinical
F-G9b		Straight Keyboard Tray w/ 9" Clip Mouse	*	*
		Location: <i>Private Office / Workstation</i> Remarks: Straight: #6G 900 90 Corner: Provide straight keyboard as noted above with corner sleeve #DE200		



Humanscale		Model	Clinical	Non-Clinical
F-G9c		Straight Keyboard Tray	*	*
		Location: <i>Private Office / Workstation</i> Remarks: Confirm that there is enough clearance to accommodate this tray. Straight: #6G 500 Corner: Provide straight keyboard as noted above with corner sleeve #DE200		
Humanscale		Model	Clinical	Non-Clinical
F-G9d		FR500	*	*
		Location: <i>Private Office / Workstation</i> Remarks: Foot rest/rocker; available in cherry and black		
Humanscale		Model	Clinical	Non-Clinical
F-G9e		FR300	*	*
		Location: <i>Private Office / Workstation</i> Remarks: Foot rest/rocker; available in natural finish		
Steelcase		Model	Clinical	Non-Clinical
F-G9f		Footrest	*	*
		Location: <i>Private Office / Workstation</i> Remarks: Footrest		
Steelcase		Model	Clinical	Non-Clinical
F-G9g		Campfire	*	*
		Location: <i>Private Office / Workstation</i> Remarks: Foot and leg rest		

H. OUTDOOR FURNITURE



In order to create and maintain a consistent brand and allow appropriate maintenance at NYU Langone Health spaces, specific furniture and accessory items are used. The list below will give the A/E Team a sense of the typical outdoor furniture used at NYU Langone facilities. It is the Architect’s responsibility to select items that are code compliant and appropriate for the capital project based on the type of space and end-user needs. The Architect and Interior Designer shall consider specifying existing building-specific standards provided they are in line with these Design Guidelines. Architects shall coordinate with the RED+F Project Manager and the Design Studio to finalize outdoor furniture selections. The images shown are for illustrative purposes only and may not be a reflection of a project’s final specification.

The product specifications included in this subsection are organized by type as follows:

- F-H1 Outdoor Seating
- F-H2 Outdoor Tables

F-H1 OUTDOOR SEATING				
Weatherend		Model	Clinical	Non-Clinical
F-H1a		Semicircular Settee		*
		Location: <u>Outdoor Space</u> Remarks: Outdoor Bench finished with “Yacht” paint in satin finish. Color to be approved by RED+F.		
Weatherend		Model	Clinical	Non-Clinical
F-H1b		Quarter Circular Settee		*
		Location: <u>Outdoor Space</u> Remarks: Outdoor Bench finished with “Yacht” paint in satin finish. Color to be approved by RED+F.		
Weatherend		Model	Clinical	Non-Clinical
F-H1c		Campobello		*
		Location: <u>Outdoor Space</u> Remarks: Outdoor Dining Arm Chair finished with “Yacht” paint in satin finish. Color to be approved by RED+F.		

Coalesse		Model	Clinical	Non-Clinical
F-H1d		Emu IVY		*
		Location: <u>Outdoor Space</u> Remarks: Lounge Chair also available as Sofa		
Landscape Forms		Model	Clinical	Non-Clinical
F-H1e		Chipman Chair		*
		Location: <u>Outdoor Space</u> Remarks: Aluminum stacking dining chair finished with silver metallic powder coat.		
Henry Hall Designs		Model	Clinical	Non-Clinical
F-H1f		Tlente Chaise		*
		Location: <u>Outdoor Space</u> Remarks: Chaise in white standard finish; Custom colors available		
Landscape Forms		Model	Clinical	Non-Clinical
F-H1g		Harpo		*
		Location: <u>Outdoor Space</u> Remarks: Available in all aluminum or wood/aluminum.		
Landscape Forms		Model	Clinical	Non-Clinical
F-H1h		Palisade		*
		Location: <u>Outdoor Space</u> Remarks: Wood bench available in 72" or 96" length.		

F-H2 OUTDOOR TABLES				
Weatherend		Model	Clinical	Non-Clinical
F-H2a		Isleboro		*
		Location: <u>Outdoor Space</u> Remarks: Outdoor Dining Table finished with “Yacht” paint in satin finish. Color to be approved by RED+F.		
Landscape Forms		Model	Clinical	Non-Clinical
F-H2b		Chipman Table		*
		Location: <u>Outdoor Space</u> Remarks: Aluminum dining table finished with silver metallic powder coat.		

PANTRY APPLIANCES

In accordance with both our Mission devoted to excellence in patient care, education, and research and our Design Principles of providing timeless designs that are cost effective, efficient, functional and practical, RED+F has compiled a collection of appliances that we have found to be successful at NYU Langone Health.

Our goals in listing these items are to:

- Streamline the design process
- Assist the Architect and Interior Designer with specifying pantry appliances
- Create spaces that are timeless, durable, easily maintainable and cost-effective
- Create a consistent NYU Langone brand

The Architect and Interior Designer should use this as a guide for specifying pantry appliances on NYU Langone capital projects. This information does not relieve the Architect or Interior Designer of specifying materials that are appropriate and code compliant for specific spaces. The Architect and Interior Designer shall consider specifying existing building-specific standards provided they are in line with these Design Guidelines. Also, the Architect and Interior Designer may suggest other products if they believe those proposed products will support our mission, design principles, and the design intent of the project.

The following ratios shall be used when specifying pantry appliances:

Item	Ratio
Microwave	1 per 75 persons
Under-counter Refrigerator / Freezer	1/3 cu. ft. per person
Refrigerator / Freezer	
Dishwasher (<i>if required</i>)	1 per 240 persons
Low-Capacity Coffee Maker	1 per 25 persons
Medium-Capacity Coffee Maker	1 per 25 - 50 persons
High-Capacity Coffee Maker	1 per 50 - 100 persons
Water Dispenser	1 per 75 persons

Abbreviations

- OFOI: Owner-Furnished, Owner-Installed
- OFCI: Owner-Furnished, Contractor-Installed
- CFCl: Contractor-Furnished, Contractor-Installed

The product specifications included in this subsection are organized by type as follows:





- A1. Microwaves
- A2. Under-counter Refrigerators / Freezers
- A3. Refrigerators / Freezers
- A4. Dishwashers
- A5. Coffee Makers
- A6. Water Dispensers



A1. MICROWAVES						
Image	Description	Manuf.	Finish	Clinical	Non-Clinical	
A1		Built-in Microwave	See Below	Stainless Steel		*
		Remarks: 2.0 – 2.2 cu. ft. w/ stainless steel trim kit (CFCI) Manufacturers: GE, Kitchenaid, LG, Maytag, Summit, Whirlpool				

A2. UNDER-COUNTER REFRIGERATORS / FREEZERS						
Image	Description	Manuf.	Finish	Clinical	Non-Clinical	
A2		Compact Ref./Freezer	Summit	Stainless Steel / Panel Ready		*
		Remarks: 5.0 – 6.0 cu. ft.; installed under 34" ADA counter height; Energy Star rated, if possible (CFCI) For Lactation Rooms, provide Summit #AL54				

A3. REFRIGERATORS / FREEZERS						
Image	Description	Manuf.	Finish	Clinical	Non-Clinical	
A3		Built-in Ref./Freezer	See Below	Stainless Steel / Panel Ready		*
		Remarks: 30" – 42" wide; counter depth; 19.0 – 24.0 cu.ft. capacity; freezer on the bottom; one / two doors on the top; no water on the door; filtered integrated automatic ice maker; Energy Star rated, if possible (CFCI) Manufacturers: Fisher & Paykel, GE, Kitchenaid, LG, Maytag, Summit, Whirlpool				

A4. DISHWASHERS						
Image	Description	Manuf.	Finish	Clinical	Non-Clinical	
A4		Built-in Dishwasher	See Below	Stainless Steel / Panel Ready		*
		Remarks: 24" wide; installed under 34" ADA counter height; controls on top; Energy Star rated, if possible (CFCI) Manufacturers: Fisher & Paykel, GE, Summit,				

A5. COFFEE MAKERS						
Image	Description	Manuf.	Model/Finish	Clinical	Non-Clinical	
A5a		Low-Capacity Coffee Maker	FETCO	CBS-2121A (w/o warmers)		*
		Dimensions: 7-5/8”w x 19”d x 19”h Remarks: Plumbed; requires filtered water and backflow prevention valve; incl. hot water spout; uses standard 4-1/2” filter; provide w/ FETCO Stainless Steel 1.9 Thermal Server(s) #D055 (OFOI)				
Image	Description	Manuf.	Model/Finish	Clinical	Non-Clinical	
A5b		Medium-Capacity Coffee Maker	Keurig	K3000SE / Silver		*
		Dimensions: 12”w x 18”d x 17.4”h Remarks: Plumbed; for use w/ k-cup pods; incl. auto-pod ejector (OFOI)				
Image	Description	Manuf.	Model/Finish	Clinical	Non-Clinical	
A5c		High-Capacity Coffee Maker	WMF	1500s		*
		Dimensions: 13”w x 24”d x 27”h (not incl. milk ref.) Remarks: Plumbed w/ 2 coffee and 1 chocolate hopper. Spec w/o warming wand. Separate fresh milk refrigerator required. Coord grind disposal options w/ RED+F based on millwork design. Requires maintenance contract. (OFOI)				
Image	Description	Manuf.	Model/Finish	Clinical	Non-Clinical	
A5d		High-Capacity Coffee Maker	Keurig Commercial	Eccellenza Touch		*
		Dimensions: 20”w x 20.25”d x 28”h Remarks: Plumbed w/ 2 bean and 3 powder dispensers. Brews to 3 brewing strengths and 3 cup sizes. User control via 10.1” programmable interactive touchscreen. Wi-Fi connection required. Requires maintenance contract. (OFOI)				
Notes: <ol style="list-style-type: none"> It is the responsibility of the User department to arrange for rental/purchase of a coffee maker through NYULH Finance. RED+F PM and A/E Team shall review the selection of coffee makers with both the User and NYU Langone’s Food & Nutrition Services and take into consideration the following: <ul style="list-style-type: none"> Occupancy count User drink preference (traditional coffee vs. espresso style drinks) Daily maintenance requirements (some machines require daily cleaning) As part of the capital construction project the A/E Team shall provide: <ul style="list-style-type: none"> all necessary plumbing and power connections countertop space for a plumbed coffee maker 						

A6. WATER DISPENSERS						
Image		Description	Manuf.	Model/Finish	Clinical	Non-Clinical
A6a		Countertop Cooler	Quench	Q7 Countertop / Black	*	*
		<p>Dimensions: 11.6”w x 17.5”d x 17.9”h</p> <p>Remarks: Bottleless disp.; hot and cold water; plumbed; LED UV light to maintain water quality; RO or carbon filtration unit to be mounted w/in base cabinet below unit; allow for dedicated ¼” cold water line to filtration system w/in base cabinet; allow for ¼” filtered water line from filtration system w/in base cabinet to unit through countertop (OFOI)</p>				
Image		Description	Manuf.	Model/Finish	Clinical	Non-Clinical
A6b		Free-standing Cooler	Quench	Q7 Freestanding / Black	*	*
		<p>Dimensions: 11.6”w x 16.5”d x 49.8”h</p> <p>Remarks: Bottleless disp.; hot and cold water; plumbed ; LED UV light to maintain water quality, RO or carbon filtration (OFOI)</p>				
<p>Notes :</p> <ol style="list-style-type: none"> 1. It is the responsibility of the User department to arrange for rental of a water cooler through NYULH Finance. 2. As part of the capital construction project the A/E Team shall provide: <ul style="list-style-type: none"> - all necessary plumbing and power connections - either countertop space or a niche for a plumbed water cooler 						

PLUMBING FIXTURES

In order to create and maintain a consistent brand and allow appropriate maintenance at NYU Langone Health spaces, specific plumbing fixtures are used. The product list provided in this subsection will give the A/E Team a sense of the typical fixtures used at NYU Langone facilities. It is the Architect’s responsibility to select items that are code compliant and appropriate for the capital project based on the type of space and end-user needs. The Architect and Interior Designer shall consider specifying existing building-specific standards provided they are in line with these Design Guidelines. Architects shall coordinate with the RED+F Project Manager, Facilities Operations and the Design Studio to finalize fixture selections. Please note the following items:

- Use all-in-one sinks and touchless flushometers in public restrooms.
- Floor mounted toilets are preferred over wall mounted toilets.
- Provide manual flushvalves and faucets in Sabbath identified restrooms.

The following fixtures are required at a minimum in restrooms:





Item	CLINICAL (INPATIENT)									
	Multi-Stall <u>Public Toilet</u> (Women’s)	Multi-Stall <u>Public Toilet</u> (Men’s)	Single Stall <u>Public Toilet</u>	Multi-Stall <u>Staff Toilet</u> (Women’s)	Multi-Stall <u>Staff Toilet</u> (Men’s)	Single Stall <u>Staff Toilet</u>	<u>Staff Locker Room</u> (Women’s)	<u>Staff Locker Room</u> (Men’s)	<u>Patient Room Toilet</u>	<u>Pediatric Patient Room Toilet</u>
Toilet (Floor Mounted)	✓	✓	✓	✓	✓	✓	✓	✓	✓	✓
Toilet Flush Valve (Automatic)	✓	✓	✓	✓	✓	✓	✓	✓	✓	✓
Urinal		✓			✓			✓		
Urinal Flush Valve (Automatic)		✓			✓			✓		
All-in-One Sink Assembly (incl. sink, faucet, soap disp. + hand dryer)	✓	✓	✓	✓	✓	✓				
Sink (if All-in-One Sink Assembly is not used)	✓	✓	✓	✓	✓	✓	✓	✓	✓	✓
Automatic Faucet (if All-in-One Sink Assembly is not used)	✓	✓	✓	✓	✓	✓	✓	✓		
Manual Faucet									✓	✓
Bedpan Washer									✓	✓
Shower							✓	✓	✓	✓



Item	CLINICAL (OUTPATIENT)								
	Multi-Stall <u>Public Toilet</u> (Women's)	Multi-Stall <u>Public Toilet</u> (Men's)	Single Stall <u>Public Toilet</u>	Multi-Stall <u>Staff Toilet</u> (Women's)	Multi-Stall <u>Staff Toilet</u> (Men's)	Single Stall <u>Staff Toilet</u>	<u>Staff Locker Room</u> (Women's)	<u>Staff Locker Room</u> (Men's)	Single Stall <u>Patient Toilet</u> (off of corridors)
Toilet (Floor Mounted)	✓	✓	✓	✓	✓	✓	✓	✓	✓
Toilet Flush Valve (Automatic)	✓	✓	✓	✓	✓	✓	✓	✓	✓
Urinal		✓			✓			✓	
Urinal Flush Valve (Automatic)		✓			✓			✓	
All-in-One Sink Assembly (incl. sink, faucet, soap disp. + hand dryer)	✓	✓	✓	✓	✓	✓			
Sink (if All-in-One Sink Assembly is not used)	✓	✓	✓	✓	✓	✓	✓	✓	✓
Automatic Faucet (if All-in-One Sink Assembly is not used)	✓	✓	✓	✓	✓	✓	✓	✓	✓
Shower							✓	✓	

Item	NON-CLINICAL							
	Multi-Stall <u>Public Toilet</u> (Women's)	Multi-Stall <u>Public Toilet</u> (Men's)	Single Stall <u>Public Toilet</u>	Multi-Stall <u>Staff Toilet</u> (Women's)	Multi-Stall <u>Staff Toilet</u> (Men's)	Single Stall <u>Staff Toilet</u>	<u>Staff Locker Room</u> (Women's)	<u>Staff Locker Room</u> (Men's)
Toilet (Floor Mounted)	✓	✓	✓	✓	✓	✓	✓	✓
Toilet Flush Valve (Automatic)	✓	✓	✓	✓	✓	✓	✓	✓
Urinal		✓			✓			✓
Urinal Flush Valve (Automatic)		✓			✓			✓
All-in-One Sink Assembly (incl. sink, faucet, soap disp. + hand dryer)	✓	✓	✓	✓	✓	✓		
Sink (if All-in-One Sink Assembly is not used)	✓	✓	✓	✓	✓	✓	✓	✓
Automatic Faucet (if All-in-One Sink Assembly is not used)	✓	✓	✓	✓	✓	✓	✓	✓
Shower							✓	✓

The product specifications included in this subsection are organized by type as follows:

- P1. Toilets
- P2. Urinals
- P3. Flush Valves
- P4. Bedpan Washers
- P5. All-in-one Sink Assemblies
- P6. Sinks
- P7. P-Trap Covers
- P8. Faucets
- P9. Showers
- P10. Drinking Fountains

P1. TOILETS						
Image	Description	Manuf.	Model/Finish	Clinical	Non-Clinical	
 <p>**Preferred**</p>	Toilet	American Standard	Huron 3342.001 / White Vitreous China	*	*	
	<p>Location: <i>Restrooms</i> Remarks: Floor mounted toilet w/ back outlet, back spud, and elongated bowl w/ integral seat, seat holes and Everclean surface; 17-1/8" rim height for ADA-compliance; holds 1,000 lbs. (Bariatric); provide w/ 1.28 gpf flush valve; spec toilet seat separately</p>					
Image	Description	Manuf.	Model/Finish	Clinical	Non-Clinical	
	Toilet	American Standard	Huron 3312.001 / White Vitreous China	*	*	
	<p>Location: <i>Restrooms (where backspud is not possible)</i> Remarks: Floor mounted toilet w/ back outlet, top spud, and elongated bowl w/ Everclean surface; 17-1/8" rim height for ADA-compliance; holds 1,000 lbs. (not Bariatric due to top spud); provide w/ 1.28 gpf flush valve; spec toilet seat separately</p>					
Image	Description	Manuf.	Model/Finish	Clinical	Non-Clinical	
	Toilet	Kohler	Modflex Adjust-a-Bowl / White Vitreous China	*	*	
	<p>Location: <i>Restrooms (for replacement of existing wall mounted toilets only)</i> Remarks: Floor mounted toilet w/ top or rear spud; replaces wall mounted toilets w/ 15" – 18" rim heights; designed not to require removal of existing wall carrier, adjustment of existing plumbing or patching of existing adjacent finishes; elongated bowl; ADA-compliant; 2,500 lb. static load; provide w/ 1.28 gpf flush valve; spec toilet seat separately #K-25042-SS (top spud) #K-25042-SSL (incl. bedpan lugs) #K-25044-SS (rear spud) #K-25044-SSL (incl. bedpan lugs) GC / Plumber to confirm feasibility prior to purchase and installation</p>					
Image	Description	Manuf.	Model/Finish	Clinical	Non-Clinical	
	Toilet	American Standard	Cadet 2988.101 / 2988.813 White Vitreous China	*	*	
	<p>Location: <i>Restrooms (for in-kind replacements only, where conversion to tankless floor mounted toilets is not possible)</i> Remarks: Floor mounted toilet w/ tank; round bowl w/ Everclean surface; 16-1/2" rim height for ADA-compliance; 1.28 gpf; spec toilet seat separately</p>					

P2. URINALS						
Image	Description	Manuf.	Model/Finish	Clinical	Non-Clinical	
 <p>**Preferred**</p>	Urinal	Toto	UT105UV#01/ Cotton	*	*	
	<p>Location: <i>Multi-stall Restrooms (Men's)</i> Remarks: Commercial Washout Ultra High-Efficiency Urinal w/ concealed integral trap, 0.125 gpf, 3/4" back spud inlet and 2" I.P.S. outlet; ADA-compliant when properly installed</p>					
Image	Description	Manuf.	Model/Finish	Clinical	Non-Clinical	
	Urinal	American Standard	6515.001 / White Vitreous China	*	*	
	<p>Location: <i>Multi-stall Restrooms (Men's)</i> Remarks: Commercial Washout Ultra High-Efficiency Urinal w/ concealed integral trap, 0.125 gpf, 3/4" back spud inlet and 2" inside outlet; ADA-compliant when properly installed</p>					
Image	Description	Manuf.	Model/Finish	Clinical	Non-Clinical	
	Urinal	Zurn	Z5759 Retrofit Pint / White Vitreous China	*	*	
	<p>Location: <i>Multi-stall Restrooms (Men's)</i> Remarks: Wall mounted retrofit urinal w/ 3/4" back spud; 0.125 gpf; ADA-compliant when properly installed</p>					

P3. FLUSH VALVES						
Image	Description	Manuf.	Model/Finish	Clinical	Non-Clinical	
 <p>**Preferred**</p>	Auto. Flush Valve (Top & Back Spud Toilets)	Toto	Ecopower Series/Stainless Steel	*	*	
	<p>Location: <i>Restrooms</i> Remarks: High-efficiency concealed electronic flushometer for toilets; 1.28 gpf; ADA-compliant when properly installed; provide 1" ball valve designed control stop by Delany Products (TruStop #1010A) #TET2LA33#SS – Back Spud Floor #TET2LA32#SS – Top Spud</p>					

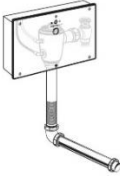





Image	Description	Manuf.	Model/Finish	Clinical	Non-Clinical
 <p>**Preferred**</p>	Automatic Flush Valve (Urinal)	Toto	Ecopower TEU2UA11#SS / Stainless Steel	*	*
	<p>Location: <u>Restrooms</u> Remarks: Ultra high-efficiency concealed electronic flush valve for back-spud urinals; 0.125 gpf; ADA-compliant when properly installed; provide ¾" ball valve designed control stop by Delany Products (TruStop #1020A)</p>				
Image	Description	Manuf.	Model/Finish	Clinical	Non-Clinical
	Auto. Flush Valve	American Standard	Selectronic 606B322 / Stainless Steel	*	*
	<p>Location: <u>Restrooms</u> Remarks: Concealed automatic flushometer; 1.28 gpf; manual override mounted at ADA height; PK00.WRK 10-year battery kit must be purchased separately; specify with appropriate connection kit for top versus back spud toilets; provide 1" ball valve designed control stop by Delany Products (TruStop #1010A)</p>				
Image	Description	Manuf.	Model/Finish	Clinical	Non-Clinical
	Automatic Flush Valve (Urinal)	American Standard	Selectronic 606B501 / Stainless Steel	*	*
	<p>Location: <u>Restrooms</u> Remarks: Concealed automatic flush valve for urinals w/ ¾" back spud; 0.125 gpf; manual override mounted at ADA height; PK00.WRK 10-year battery kit must be purchased separately; provide ¾" ball valve designed control stop by Delany Products (TruStop #1020A)</p>				
Image	Description	Manuf.	Model/Finish	Clinical	Non-Clinical
	Auto. Flush Valve (Back Spud Toilets)	American Standard	Selectronic 606B221 / Polished Chrome	*	
	<p>Location: <u>Back Spud Toilets w/ Bedpan Washers</u> Remarks: Concealed, sensor operated Selectronic flush valve for toilets (w/ rear access) w/ 1-1/2" concealed back spud bowls; 1.28 gpf; manual override to be mounted at ADA height; PK00.WRK 10-year battery kit must be purchased separately; provide 1" ball valve designed control stop by Delany Products (TruStop #1010A)</p>				

Image	Description	Manuf.	Model/Finish	Clinical	Non-Clinical
	Auto. Flush Valve (Top Spud Toilets)	American Standard	Selectronic 6066121.002 / Polished Chrome	*	*
	Location: <u>Back of House Restrooms/ Staff Locker Rooms</u> Remarks: Exposed, sensor-operated flush valve for toilets w/ 1-1/2" top spud bowls; 1.28 gpf; w/ 10-year battery life; ADA-compliant; provide 1" ball valve designed control stop by Delany Products (TruStop #1010A)				
Image	Description	Manuf.	Model/Finish	Clinical	Non-Clinical
	Manual Flush Valve (Top Spud Toilets)	American Standard	Manual FloWise 6047121.002 / Polished Chrome	*	*
	Location: <u>Sabbath Restrooms</u> Remarks: Exposed, manual operation flush valve for toilets w/ top spud, 1.28 gpf; ADA-compliant; provide 1" ball valve designed control stop by Delany Products (TruStop #1010A)				

P4. BEDPAN WASHERS					
Image	Description	Manuf.	Model/Finish	Clinical	Non-Clinical
	Bedpan Washer	Meiko	Topline 30WC DT NDV RH ADA /#4 Stainless Steel	*	
	Location: <u>Patient Rooms (mounted above toilet)</u> Remarks: 480V model, flush mount, mounted above toilet; shall meet NYC Plumbing Code requirements and UL Listings; provide cutout for flushometer P3e sensor Note: Coordination with toilet and shop drawings by Meiko is req'd.				
Image	Description	Manuf.	Model/Finish	Clinical	Non-Clinical
	Bedpan Washer	Meiko	Topline 30 DT NDV RH /#4 Stainless Steel	*	
	Location: <u>Periop and NIBS Internal Toilets to all Patient Rooms / Soiled Workrooms</u> Remarks: 480V model, flush mount; shall meet all NYC Plumbing Code requirements and UL Listings Note: Coordination with toilet and shop drawings by Meiko is req'd.				

Image	Description	Manuf.	Model/Finish	Clinical	Non-Clinical
<p>P4c</p> 	<p>Bedpan Washer w/ Flushing Rim Sink</p>	<p>American Standard</p>	<p>Clinic Service Sink 9512.999.020</p>	<p>*</p>	
	<p>Location: <u>Soiled Utility and Janitor's Closet</u> Remarks: Wall hung clinic service sink w/ blow-out flushing rim and 1-1/2" top inlet; Provide stainless steel guards American Std #7832512.075(2 x side rim guard) and #7832504.075 (1 x front rim guard); use manual clinic flush valve P4d and bedpan diverter/washer P4e shown below</p>				
Image	Description	Manuf.	Model/Finish	Clinical	Non-Clinical
<p>P4d</p> 	<p>Manual Clinic Sink Flush Valve</p>	<p>American Standard</p>	<p>6047.117.002</p>	<p>*</p>	
	<p>Location: <u>Soiled Utility and Janitor's Closet</u> Remarks: Manual clinic sink flush valve; 6.5 gpm; use with bedpan washer P4c</p>				
Image	Description	Manuf.	Model/Finish	Clinical	Non-Clinical
<p>P4e</p> 	<p>Bedpan Diverter / Washer</p>	<p>American Standard</p>	<p>6047.800.002</p>	<p>*</p>	
	<p>Location: <u>Soiled Utility and Janitor's Closet</u> Remarks: Bedpan washer diverter assembly with straight down tube; operates at 1.28 and 1.6 gpf; use with bedpan washer P4c</p>				





P5. ALL-IN-ONE SINK ASSEMBLIES						
Image	Description	Manuf.	Model/Finish	Clinical	Non-Clinical	
P5a		All-in-One Sink Assembly (Option 1)	Bradley	Verge LVQ-Series w/ Washbar WB1 & Multi-Feed Top Fill Soap Kit	*	*
		<p>Location: <i>Restrooms</i></p> <p>Remarks: All-in-one Evero quartz trough sink w/ slotted drain cover and ADA-compliant stainless steel lower enclosure w/ thumb screws. Washbar WB1 all-in-one handwash fixture (P5c) and Multi-Feed Top Fill Soap Kit (P5d) are included as part of this assembly when below model #s are used:</p> <p><u>One-Station (30" length w/ 1x P5c and 1x One-Station P5d included):</u> LVQD1-WB1-5-F-TI-HD1-AC-DR2-STAIN-TS-S-CHROME-PC</p> <p><u>Two-Station (60" length w/ 2x P5c and 1x Two-Station P5d included):</u> LVQD2-WB1-5-F-TI-HD1-AC-DR2-STAIN-TS-S-CHROME-PC</p> <p><u>Three-Station (90" length w/ 3x P5c and 1x Three-Station P5d included):</u> LVQD3-WB1-5-F-TI-HD1-AC-DR2-STAIN-TS-S-CHROME-PC</p> <p>Coordinate w/ sink assembly manufacturer for NYULH approved shop drawings and electrical requirements and locations; maintain min. 2" gap between sink and adjacent walls if located within niche; provide necessary blocking/backing to support this assembly. (Approval by RED+F Senior Leadership required.)</p>				
P5b		All-in-One Sink Assembly (Option 2)	Neo-Metro / Bradley	Slab-Edge Solid Surface Basin	*	*
		<p>Location: <i>Restrooms</i></p> <p>Remarks: All-in-one cast solid surface trough sink w/ continuous ADA-compliant stainless steel lower enclosure w/ standard hex head cap screws, custom overflow and pre-drilled holes for Bradley Washbar WB1 all-in-one handwash fixture (P5c) and Bradley Multi-Feed Top Fill Soap Kit (P5d).</p> <p><u>One-Station (30" length):</u> M9151-L018 (1x P5c and 1x One-Station P5d specified / purchased separately)</p> <p><u>Two-Station (60" length):</u> M9152-L038 (2x P5c and 1x Two-Station P5d specified / purchased separately)</p> <p><u>Three-Station (90" length):</u> M9153-L045 (3x P5c and 1x Three-Station P5d specified / purchased separately)</p> <p><u>Four-Station (120" length):</u> M9153-L035 (4x P5c and 2x Two-Station P5d specified / purchased separately)</p> <p><u>Five-Station (150" length):</u> M9153-L036 (One-Station + Three-Station + One-Station connected) (5x P5c, 2x One-Station P5d and 1x Three-Station P5d specified / purchased separately)</p> <p>Coordinate w/ sink assembly manufacturer for NYULH approved shop drawings and electrical requirements and locations; maintain min. 2" gap between sink and adjacent walls if located within niche; provide necessary blocking/backing to support this assembly. (Approval by RED+F Senior Leadership required.)</p>				

Image	Description	Manuf.	Model/Finish	Clinical	Non-Clinical
 <p>P5c</p>	All-in-One Washbar	Bradley	WB1-5-F-TI-HD1-AC-PC / Polished Chrome	*	*
	<p>Location: <u>Restrooms</u> Remarks: All-in-one handwash fixture w/ AC adapter including foam soap dispenser , faucet (0.5 gpm) and hand dryer (to be field set to “medium”; see video at: https://youtu.be/ISIKF8S3QU8); (1) one dedicated electrical outlet on its own dedicated circuit is required per washbar below sink assembly w/in stl stl lower enclosure (coor’d exact outlet location with mfr/rep); ADA compliant included with sink assembly P5a; must be specified and purchased separately for use with sink assembly P5b</p>				
Image	Description	Manuf.	Model/Finish	Clinical	Non-Clinical
 <p>P5d</p>	Multi-feed Top Fill Soap System	Bradley	Varies / Polished Chrome	*	*
	<p>Location: <u>Restrooms</u> Remarks: Verge Multi-Feed Top Fill Soap System in Polished Chrome w/ AC Splitter Adapter; included with sink assembly P5a; must be specified / purchased separately for use with sink assembly P5b <u>One-Station (1x soap tank to supply 1x WB1 fixture):</u> WB-TF-1-F-AC-PC <u>Two-Station (1x soap tank to supply 2x WB1 fixtures):</u> WB-TF-2-F-AC-PC <u>Three-Station (2x soap tanks to supply 3x WB1 fixtures):</u> WB-TF-3-F-AC-PC</p>				



P6. SINKS					
Image	Description	Manuf.	Model/Finish	Clinical	Non-Clinical
 <p>P6a</p>	Sink	Kohler	Caxton K-2210 / White Vitreous China	*	*
	<p>Location: <u>Restrooms</u> Remarks: Undercounter mount sink w/ overflow</p>				
Image	Description	Manuf.	Model/Finish	Clinical	Non-Clinical
 <p>P6b</p>	Sink	American Standard	Ovalyn 9482.000 / White Vitreous China	*	*
	<p>Location: <u>Restrooms</u> Remarks: Undercounter mount sink w/ overflow</p>				





Image		Description	Manuf.	Model/Finish	Clinical	Non-Clinical
P6c		Sink	Kohler	Ladena K-2214/ White Vitreous China	*	*
		Location: <u>Restrooms</u> Remarks: Undercounter mount sink w/ overflow				
Image		Description	Manuf.	Model/Finish	Clinical	Non-Clinical
P6d		Sink	Kohler	Verticyl K-2881-0 (Oval)	*	*
		Location: <u>Restrooms</u> Remarks: Undercounter mount sink w/ overflow		Verticyl K-2882-0 (Rectangular)	*	*
				Verticyl K-2883-0 (Round)	*	*
Image		Description	Manuf.	Model/Finish	Clinical	Non-Clinical
P6e		Sink	American Standard	Decorum 913400XEC / White Vitreous China		*
		Location: <u>Single Stall Restrooms</u> Remarks: Wall hung sink w/ rear overflow, Everclean surface; faucet hole configurations vary (see manufacturer spec); ADA-compliant when properly installed; provide with #0059.020EC shroud				
Image		Description	Manuf.	Model/Finish	Clinical	Non-Clinical
P6f		Sink	American Standard	Murro / White Vitreous China		*
		Location: <u>Single Stall Restrooms / Staff Locker Rooms</u> Remarks: Wall hung sink w/ overflow, Everclean surface; faucet hole configurations vary (see manufacturer spec); ADA-compliant when properly installed; provide with #0059.020EC shroud				
Image		Description	Manuf.	Model/Finish	Clinical	Non-Clinical
P6g		Sink	Kohler	Soho K-2084 / White Vitreous China	*	*
		Location: <u>Back of House Restrooms / Staff Locker Rooms</u> Remarks: Wall hung sink w/ overflow less soap dispenser hole; drilled for concealed arm carrier; single center hole				





Image	Description	Manuf.	Model/Finish	Clinical	Non-Clinical
	Sink	Kohler	Soho K-2053 / White Vitreous China	*	*
	Location: <u>Back of House Restrooms / Staff Locker Rooms</u> Remarks: Wall hung sink w/ overflow less soap dispenser hole; drilled for concealed arm carrier; 8" centers				
Image	Description	Manuf.	Model/Finish	Clinical	Non-Clinical
	Sink	American Standard	Lucerne 0355 / 0356 White Vitreous China	*	*
	Location: <u>Back of House Restrooms / Staff Locker Rooms</u> Remarks: Wall hung sink w/ overflow; faucet hole configurations vary (see manufacturer spec)				
Image	Description	Manuf.	Model/Finish	Clinical	Non-Clinical
	Sink	American Standard	ICS Sink 9118.111 / White Vitreous China	*	
	Location: <u>Entryway of Inpatient Rooms</u> Remarks: Wall hung sink w/ permanent Everclean surface; includes offset grid drain and P-trap w/ Saniguard coating; designed w/ sealed overflow; use faucet P8d				
Image	Description	Manuf.	Model/Finish	Clinical	Non-Clinical
	Sink	TBD	Custom / Integral Solid Surface	*	
	Location: <u>Entryway of Inpatient Rooms</u> Remarks: Integral solid surface sink to coordinate w/ solid surface countertops; provide w/ front bowl overflow				
Image	Description	Manuf.	Model/Finish	Clinical	Non-Clinical
	Sink	Corian	Neat 802P / Corian	*	
	Location: <u>Exam Room</u> Remarks: Integral Corian solid surface sink, coordinates w/ Corian solid surface countertops; sink w/ front bowl overflow				

Image		Description	Manuf.	Model/Finish	Clinical	Non-Clinical
P6m		Sink	Corian	8254 / Acrylic-modified Polyester	*	
		Location: <u>Exam Room</u> Remarks: Acrylic-modified polyester sink, coordinates w/ Corian vanity tops; sink w/ front bowl overflow				
Image		Description	Manuf.	Model/Finish	Clinical	Non-Clinical
P6n		Sink	Elkay	ELUH1113DBG / Lustertone Stl. Stl.	*	
		Location: <u>Exam Room</u> Remarks: Single bowl undermount sink w/ Lustertone finish; rear center drain placement and sound guard				
Image		Description	Manuf.	Model/Finish	Clinical	Non-Clinical
P6o		Sink	Elkay	ELUHAD131655PD / Lustertone Stl. Stl.	*	*
		Location: <u>Lactation Rooms</u> Remarks: Undermount single bowl sink				
Image		Description	Manuf.	Model/Finish	Clinical	Non-Clinical
P6p		Sink	Elkay	ELUHAD191655 / Lustertone Stl. Stl.	*	*
		Location: <u>Pantry</u> Remarks: Undermount single bowl sink				
Image		Description	Manuf.	Model/Finish	Clinical	Non-Clinical
P6q		Sink	Elkay	ELUHAD211555PD / Lustertone Stl. Stl.	*	*
		Location: <u>Pantry</u> Remarks: Undermount single bowl sink				









Image		Description	Manuf.	Model/Finish	Clinical	Non-Clinical
P6r		Sink	Elkay	ELUHAD211545PD / Lustertone Stl. Stl.	*	*
		Location: <u>Pantry</u> Remarks: Undermount single bowl sink for use at prefab casework.				
Image		Description	Manuf.	Model/Finish	Clinical	Non-Clinical
P6s		Sink	Kohler	K-3894 / Stainless Steel	*	*
		Location: <u>Pantry</u> Remarks: Under-mount single bowl sink				
Image		Description	Manuf.	Model/Finish	Clinical	Non-Clinical
P6t		Sink	Elkay	ELVWO2219 / Satin Stainless Steel	*	
		Location: <u>Laboratories</u> Remarks: Wall hung sink w/ rear overflow; faucet hole configurations vary (see manufacturer spec)				
Image		Description	Manuf.	Model/Finish	Clinical	Non-Clinical
P6u		Sink (Handwash)	Elkay	LRAD / Lustertone Stl. Stl.	*	
		Location: <u>Clinical Back of House Spaces</u> Remarks: Self-rimming drop in sink w/ grid drain; faucet and drain hole configurations vary (see manufacturer spec)				
Image		Description	Manuf.	Model/Finish	Clinical	Non-Clinical
P6v		Sink (Large/Deep)	Elkay	DLR191910 / Satin Stainless Steel	*	
		Location: <u>Clinical Back of House Spaces</u> Remarks: Drop in sink w/o overflow; faucet hole configurations vary (see manufacturer spec)				

Image		Description	Manuf.	Model/Finish	Clinical	Non-Clinical
P6 w		Mop Sink	Just Mfg.	C-2523 / Satin Stainless Steel	*	*
		Location: <u>Janitor's Closet</u> Remarks: Floor mounted mop sink; use faucet P8I				
Image		Description	Manuf.	Model/Finish	Clinical	Non-Clinical
P6x		Mop Sink	Just Mfg.	A-47699 / Satin Stainless Steel	*	*
		Location: <u>Janitor's Closet</u> Remarks: Floor mounted mop sink; use faucet P8I				

P7. P-TRAP COVERS						
Image		Description	Manuf.	Model/Finish	Clinical	Non-Clinical
P7a		ADA Undersink P-Trap Cover	Lacava	RA098 / Varies	*	*
		Location: <u>Front-of-House (As Required)</u> Remarks: ADA-compliant undersink P-Trap cover w/ clip-on installation; works on most American traps				
Image		Description	Manuf.	Model/Finish	Clinical	Non-Clinical
P7b		ADA Undersink P-Trap Cover	Plumbing Supply.com	Pro-eXtreme Series	*	*
		Location: <u>Back-of-House (As Required)</u> Remarks: ADA-compliant undersink P-Trap cover w/ snap lock fasteners; model and accessories TBD based on sink selection				









P8. FAUCETS						
Image	Description	Manuf.	Model/Finish	Clinical	Non-Clinical	
P8a		Faucet	Sloan	EAF-275-ISM CP / Polished Chrome	*	*
		Location: <u>Restrooms</u> Remarks: Battery powered w/ solar energy harvesting, sensor activated, electronic hand washing faucet for pre-tempered or hot and cold water operation; 0.5 gpm; ADA-compliant				
Image	Description	Manuf.	Model/Finish	Clinical	Non-Clinical	
P8b		Faucet	American Standard	605B105.002 w/ mixing valve	*	*
		Location: <u>Restrooms</u> Remarks: NYC DOH Article 28 compliant Self-closing, thermal mixing faucet, w/ laminar flow and 12-hour auto purge; 0.5 gpm; power kits and mixing valve to be selected and purchased separately; ADA-compliant				
Image	Description	Manuf.	Model/Finish	Clinical	Non-Clinical	
P8c		Faucet	American Standard	Varies	*	*
		Location: <u>Restrooms / Entryway of Inpatient Rooms</u> Remarks: Self-closing, thermal mixing faucet w/ 12-hour auto purge, laminar flow and side mixer; CR-P2 lithium battery preinstalled (5 years @ 4,000 uses per month); ADA-compliant #7755.303 (at Restrooms) – 0.35 gpm #7755.305 (at Restrooms) – 0.5 gpm #7755.315 (at Entryway of Inpatient Rooms)– 1.5 gpm				
Image	Description	Manuf.	Model/Finish	Clinical	Non-Clinical	
P8d		Faucet	American Standard	Selectronic IC Faucet 605B.163 w/ mixing valve 605XTMV1070	*	*
		Location: <u>Entryway of Inpatient Rooms</u> Remarks: Self-closing, thermal mixing faucet; 12-hour auto purge, laminar flow; 1.5 gpm; w/ long-life battery power; for use w/ ICS Sinks; power kits must be purchased separately				
Image	Description	Manuf.	Model/Finish	Clinical	Non-Clinical	
P8e		Faucet	Kohler	K-7516 / Stl Stl or Polished Chrome	*	*
		Location: <u>Restrooms</u> Remarks: Single hole mounting electronic faucet w/ vandal-resistant aerator, available w/ and w/o mixer, less drain, 0.5 gpm; ADA-compliant				

Image	Description	Manuf.	Model/Finish	Clinical	Non-Clinical
<p>P8f</p>	Manual Faucet (Metering)	Chicago Faucets	3500-E2805ABCP / Polished Chrome	*	*
	<p>Location: <u>Sabbath Restrooms</u> Remarks: Single hole, self-closing, manual, metering faucet w/ vandal proof non-aerating spray; 0.5 gpm; ADA-compliant</p>				
Image	Description	Manuf.	Model/Finish	Clinical	Non-Clinical
<p>P8g</p>	Faucet	Elkay	LK7921SSS / Satin Stl Stl		*
	<p>Location: <u>Pantry / Staff Lounge / Lactation Room</u> Remarks: Single hole, manual kitchen faucet; 1.5 gpm; ADA-compliant</p>				
Image	Description	Manuf.	Model/Finish	Clinical	Non-Clinical
<p>P8h</p>	Faucet	American Standard	Monterrey 7545.170	*	
	<p>Location: <u>Handwash Areas / Soiled Utility / Restrooms</u> Remarks: Two-handle, centerset, gooseneck spout lavatory faucet w/ vandal-resistant wrist blades, ADA-compliant #7545.170-V05 (at Restrooms) – 0.5 gpm vandal-resistant, pressure compensating multi-laminar spray #7545.170-LV15 (at Handwash Areas / Soiled Utility) – 1.5 gpm vandal-resistant, pressure compensating, non-aerated laminar flow outlet</p>				
Image	Description	Manuf.	Model/Finish	Clinical	Non-Clinical
<p>P8i</p>	Faucet	American Standard	Monterrey 6545.170	*	
	<p>Location: <u>Exam Room / Handwash Areas / Soiled Utility / Restrooms</u> Remarks: NYC DOH Article 28 compliant Two-handle, 8" widespread lavatory faucet w/ vandal proof wrist blades and gooseneck spout; ADA-compliant #6545.170-V05 (at Restrooms) – 0.5 gpm vandal-resistant, pressure compensating multi-laminar spray #6545.170-LV15 (at Handwash Areas / Soiled Utility) – 1.5 gpm vandal-resistant, pressure compensating, non-aerated laminar flow outlet</p>				

Image	Description	Manuf.	Model/Finish	Clinical	Non-Clinical
	Faucet	Chicago Faucets	786-GN2FCABCP	*	
	Location: <u>Exam Rooms / Handwash Areas / Soiled Utility</u> Remarks: Deck mounted sink faucet w/ 8" fixed centers, concealed hot and cold water, 4" vandal proof wrist blades, 1.5 gpm laminar flow; ADA-compliant				
Image	Description	Manuf.	Model/Finish	Clinical	Non-Clinical
	Faucet	T & S Brassworks	B-1152	*	*
	Location: <u>Procedure Floor Decontamination</u> Remarks: Deck mounted w/ rigid swing nozzle aerator, wrist blades and 4-ft stainless steel hose w/ spray valve, 2.2 gpm				
Image	Description	Manuf.	Model/Finish	Clinical	Non-Clinical
	Faucet	Chicago Faucets	897-RCF w/ 317-PRJ KCP Wrist blades / Rough Chrome	*	*
	Location: <u>Janitor's Closet (Patient and Procedure Floors)</u> Remarks: Wall mounted manual faucet w/ 8" body, adjustable arms, vandal proof lever handles, vacuum breaker spout w/ pail hook and wall brace; ADA-compliant				







P9. SHOWERS					
Image	Description	Manuf.	Model/Finish	Clinical	Non-Clinical
	Shower w/ Slide Grab Bar	Moen	52236GBM15 / Chrome + Stl. Stl.	*	
	Location: <u>Patient Rooms and ADA Staff Showers</u> Remarks: Single function, handheld shower w/ stainless steel slide grab bar, mounted at ADA height, w/ non-positive cut off button and plastic hose; provide w/ P9c mixing valve; ADA-compliant * order w/ extra clips				
Image	Description	Manuf.	Model/Finish	Clinical	Non-Clinical
	Shower	Moen	52716EP15 / Chrome Plated	*	
	Location: <u>Non-ADA Staff Showers</u> Remarks: Fixed mount, vandal resistant showerhead; provide w/ P9c mixing valve				

Image	Description	Manuf.	Model/Finish	Clinical	Non-Clinical
	Mixing Valve	Moen	8370 / Chrome Plated	*	
	Location: <i>Patient Rooms and Staff Showers</i> Remarks: Single-handle pressure balancing valve only with integral stops; 1.5 gpm				
Notes : 1. Refer to the Material Legend subsection of these Design Guidelines for information on shower curtains and related hardware.					



P10. DRINKING FOUNTAINS					
Image	Description	Manuf.	Model/Finish	Clinical	Non-Clinical
	Drinking Fountain w/ Bottle Filler (Recessed)	Elkay	LZWS-EDFPBM117K / Stainless Steel	*	*
	Location: <i>Varies</i> Remarks: In-wall filtered drinking fountain / water bottle filling station; ADA-compliant when properly installed				
	Drinking Fountain (Hi/Low Combo)	Filtrine	107-16-HL-VP-TM / Satin Stainless Steel	*	*
	Location: <i>Varies</i> Remarks: Vandal proof drinking fountain w/o chiller, w/ bottle filler, integral water filter and bubbler; ADA-compliant when properly installed				
	Water Disp. w/ Bottle Filler (Recessed)	Filtrine	B103-C2-TM / Satin Stainless Steel	*	*
	Location: <i>Reception / Waiting Areas / Family Lounge</i> Remarks: In-wall water dispenser / water bottle filling station w/ built-in Taste Master water purifier and (approx. 100 count) bottom loading dual cup dispensers; fits in standard 4" wall; ADA-compliant when properly installed				



EMERGENCY PLUMBING FIXTURES

In order to create and maintain a consistent brand and allow appropriate maintenance at NYU Langone Health spaces, specific emergency fixtures are used. The list below will give the A/E Team a sense of the typical fixtures used at NYU Langone facilities. It is the Architect’s responsibility to select items that are code compliant and appropriate for the capital project based on the type of space and end-user needs. The Architect and Interior Designer shall consider specifying existing building-specific standards provided they are in line with these Design Guidelines. Architects shall coordinate with the RED+F Project Manager, Facilities Operations, Environmental Health & Safety and the Design Studio to finalize fixture selections.

The product specifications included in this subsection are organized by type as follows:

- E1. Eyewash / Drench Hose
- E2. Eyewash / Shower
- E3. Supply Box

E1. EYEWASH / DRENCH HOSE				
Image		Description	Manuf.	Model/Finish
E1a		Eyewash/Drench Hose	Guardian	G5026-FSH-VB
		Remarks: Wall mounted combination eyewash and drench hose w/ stainless steel hose and in-line vacuum breaker		
Image		Description	Manuf.	Model/Finish
E1b		Eyewash/Drench Hose	Guardian	G5022-FSH-VB
		Remarks: Deck mounted combination eyewash and drench hose w/ stainless steel hose and in-line vacuum breaker		
Image		Description	Manuf.	Model/Finish
E1c		Eyewash/Drench Hose	Water Saver	EW1022-BP/ Stainless Steel and PVC
		Remarks: Deck mounted combination eyewash and drench hose w/ PVC hose, stainless steel lever handler and backflow preventer		

E2. EYEWASH / SHOWER				
Image	Description	Manuf.	Model/Finish	
E2a		Eyewash/Shower	Water Saver	SSBF2152 / Brushed Stainless Steel
		Remarks: Recessed barrier-free eye/face wash and shower safety station w/ ceiling mounted exposed shower head and drain pan; ADA-compliant		
Image	Description	Manuf.	Model/Finish	
E2b		Eyewash/Shower	Guardian	GBF2452 / Brushed Stainless Steel
		Remarks: Recessed barrier-free eye/face wash and shower safety station for use in clean rooms (ideal for use in semiconductor, electronics and pharmaceutical applications); unit comes w/ ceiling mounted exposed shower head and drain pan; ADA-compliant		
Image	Description	Manuf.	Model/Finish	
E2c		Emergency Shower	Guardian	G1629 SE-575-SD-238-FLW-SSH
		Remarks: Emergency shower for recess mounting in finished ceiling or soffit, w/ stay-open ball valve; shower activated by rigid pull rod		

E3. SUPPLY BOX				
Image	Description	Manuf.	Model/Finish	
E3a		Supply Box	Acorn	M8195-E501-LL
		Location: <u>Emergency Preparedness</u> Remarks: Side opening door w/ hinge on right, brass piping and valve, brass ball valve; door shall be *less logo*; provide quick connect parts 1295-006-000 and 1295-007-000; cold and hot water; provide gasket b/w door and box; provide vacuum breaker on water supply		

TOILET ACCESSORIES

In order to create and maintain a consistent brand and allow appropriate maintenance at NYU Langone Health spaces, specific toilet accessories are used. The product list provided in this subsection will give the A/E Team a sense of the typical items used at NYU Langone facilities. It is the Architect's responsibility to select items that are code compliant and appropriate for the capital project based on the type of space and end-user needs. The Architect and Interior Designer shall consider specifying existing building-specific standards provided they are in line with these Design Guidelines. Architects shall coordinate with the RED+F Project Manager, Facilities Operations and the Design Studio to finalize product selections. Please note the following items are preferred over others:

- Electric hand dryers are preferred over manual paper towel dispensers in all non-patient care areas and public restrooms on patient floors.
- Manual paper towel dispensers are preferred in patient care areas.
- Recessed accessories are preferred over surface mounted / semi-recessed accessories.

Abbreviations

- OFCI: Owner-Furnished, Contractor-Installed
- CFCl: Contractor-Furnished, Contractor-Installed

The product specifications included in this subsection are organized by type as follows:



- T1. Toilet Partitions
- T2. Urinal Screen
- T3. Toilet Accessory All-in-One Dispensers
- T4. Toilet Paper Dispensers
- T5. Sanitary Napkin Disposal
- T6. Toilet Seat Cover Dispensers
- T7. Grab Bars
- T8. Coat Hooks
- T9. Soap Dispensers
- T10. Hand Dryers
- T11. Paper Towel Dispensers
- T12. Waste Receptacles
- T13. Door Tissue
- T14. Mirrors
- T15. Shelves
- T16. Air Fresheners
- T17. Baby Changing Station
- T18. Shower Accessories
- T19. Mop and Broom Holder



The following accessories are required at a minimum in restrooms:



Item	CLINICAL (INPATIENT)									
	Multi-Stall <u>Public Toilet</u> (Women's)	Multi-Stall <u>Public Toilet</u> (Men's)	Single Stall <u>Public Toilet</u>	Multi-Stall <u>Staff Toilet</u> (Women's)	Multi-Stall <u>Staff Toilet</u> (Men's)	Single Stall <u>Staff Toilet</u>	<u>Staff Locker Room</u> (Women's)	<u>Staff Locker Room</u> (Men's)	<u>Patient Room Toilet</u>	<u>Pediatric Patient Room Toilet</u>
Toilet Partitions (as required)	✓	✓		✓	✓		✓	✓		
Urinal Screen (as required)		✓			✓			✓		
All-in-One Toilet Accessory Dispenser	✓	✓	✓	✓	✓	✓	✓	✓		
Toilet Paper Dispenser ¹	✓	✓	✓	✓	✓	✓	✓	✓	✓	✓
Sanitary Napkin Disposal ¹	✓		✓	✓		✓	✓			
Toilet Seat Cover Dispenser ¹	✓	✓	✓	✓	✓	✓	✓	✓		
“Do Not Flush” Signage (above toilet)	✓	✓	✓	✓	✓	✓	✓	✓	✓	✓
Grab Bars (as required by code)	✓	✓	✓	✓	✓	✓	✓	✓	✓	✓
Nurse Call (as required by code)			✓						✓	✓
Coat Hooks	✓	✓	✓	✓	✓	✓	✓	✓	✓	✓
All-in-One Sink Assembly (incl. sink, faucet, soap disp. + hand dryer)	✓	✓	✓	✓	✓	✓				
Soap Dispenser ²	✓	✓	✓	✓	✓	✓	✓	✓	✓	✓
Hand Dryer ²	✓	✓	✓	✓	✓	✓	✓	✓		
Paper Towel Dispenser (w/ waste recep.)	✓	✓	✓	✓	✓	✓	✓	✓	✓	✓
Waste Receptacles ³	✓	✓	✓	✓	✓	✓	✓	✓	✓	✓
Door Tissue (as required)	✓	✓	✓	✓	✓	✓				
Mirror	✓	✓	✓	✓	✓	✓	✓	✓	✓	✓
Built-in Counter (incl. mirror + counter)	✓	✓		✓	✓		✓	✓		
Shelf (adjacent to sink / toilet)			✓			✓			✓	✓
Air Freshener	✓	✓	✓	✓	✓	✓	✓	✓		
Baby Changing Station	✓	✓	✓							
Folding Shower Seat (as required by code)							✓	✓	✓	✓
Recessed in-Shower Soap Shelf							✓	✓	✓	✓
Towel Hook							✓	✓	✓	✓
Notes:										
1.	If All-in-One Toilet Accessory Dispenser is not used.									
2.	If All-in-One Sink Assembly is not used.									
3.	Placement of waste receptacles should be evaluated for ADA compliance, anticipated waste capacity and whether paper towel dispensers with integral waste receptacles that may already be provided.									





Item	CLINICAL (OUTPATIENT)								
	Multi-Stall <u>Public</u> Toilet (Women’s)	Multi-Stall <u>Public</u> Toilet (Men’s)	Single Stall <u>Public</u> Toilet	Multi-Stall <u>Staff</u> Toilet (Women’s)	Multi-Stall <u>Staff</u> Toilet (Men’s)	Single Stall <u>Staff</u> Toilet	<u>Staff</u> Locker Room (Women’s)	<u>Staff</u> Locker Room (Men’s)	Single Stall <u>Patient</u> Toilet (off of corridors)
Toilet Partitions (as required)	✓	✓		✓	✓		✓	✓	
Urinal Screen (as required)		✓			✓			✓	
All-in-One Toilet Accessory Dispenser	✓	✓	✓	✓	✓	✓	✓	✓	✓
Toilet Paper Dispenser ¹	✓	✓	✓	✓	✓	✓	✓	✓	✓
Sanitary Napkin Disposal ¹	✓		✓	✓		✓	✓		✓
Toilet Seat Cover Dispenser ¹	✓	✓	✓	✓	✓	✓	✓	✓	✓
“Do Not Flush” Signage (above toilet)	✓	✓	✓	✓	✓	✓	✓	✓	✓
Grab Bars (as required by code)	✓	✓	✓	✓	✓	✓	✓	✓	✓
Nurse Call (as required by code)			✓						✓
Coat Hooks	✓	✓	✓	✓	✓	✓	✓	✓	✓
All-in-One Sink Assembly (incl. sink, faucet, soap disp. + hand dryer)	✓	✓	✓	✓	✓	✓			
Soap Dispenser ²	✓	✓	✓	✓	✓	✓	✓	✓	✓
Hand Dryer ²	✓	✓	✓	✓	✓	✓	✓	✓	✓
Paper Towel Dispenser (w/ waste recep.)	✓	✓	✓	✓	✓	✓	✓	✓	✓
Waste Receptacles ³	✓	✓	✓	✓	✓	✓	✓	✓	✓
Door Tissue (as required)	✓	✓	✓	✓	✓	✓			✓
Mirror	✓	✓	✓	✓	✓	✓	✓	✓	✓
Built-in Counter (incl. mirror + counter)	✓	✓		✓	✓		✓	✓	
Shelf (adjacent to sink / toilet)			✓			✓			✓
Air Freshener	✓	✓	✓	✓	✓	✓	✓	✓	✓
Baby Changing Station	✓	✓	✓						
Folding Shower Seat (as required by code)							✓	✓	
Recessed in-Shower Soap Shelf							✓	✓	
Towel Hook							✓	✓	
Notes: 1. If All-in-One Toilet Accessory Dispenser is not used. 2. If All-in-One Sink Assembly is not used. 3. Placement of waste receptacles should be evaluated for ADA compliance, anticipated waste capacity and whether paper towel dispensers with integral waste receptacles that may already be provided.									



Item	NON-CLINICAL							
	Multi-Stall Public Toilet (Women's)	Multi-Stall Public Toilet (Men's)	Single Stall Public Toilet	Multi-Stall Staff Toilet (Women's)	Multi-Stall Staff Toilet (Men's)	Single Stall Staff Toilet	Staff Locker Room (Women's)	Staff Locker Room (Men's)
Toilet Partitions (as required)	✓	✓		✓	✓		✓	✓
Urinal Screen (as required)		✓			✓			✓
All-in-One Toilet Accessory Dispenser	✓	✓	✓	✓	✓	✓	✓	✓
Toilet Paper Dispenser ¹	✓	✓	✓	✓	✓	✓	✓	✓
Sanitary Napkin Disposal ¹	✓		✓	✓		✓	✓	
Toilet Seat Cover Dispenser ¹	✓	✓	✓	✓	✓	✓	✓	✓
“Do Not Flush” Signage (above toilet)	✓	✓	✓	✓	✓	✓	✓	✓
Grab Bars (as required by code)	✓	✓	✓	✓	✓	✓	✓	✓
Coat Hooks	✓	✓	✓	✓	✓	✓	✓	✓
All-in-One Sink Assembly (incl. sink, faucet, soap disp. + hand dryer)	✓	✓	✓	✓	✓	✓		
Soap Dispenser ²	✓	✓	✓	✓	✓	✓	✓	✓
Hand Dryer ²	✓	✓	✓	✓	✓	✓	✓	✓
Paper Towel Dispenser (w/ waste recep.)	✓	✓	✓	✓	✓	✓	✓	✓
Waste Receptacles ³	✓	✓	✓	✓	✓	✓	✓	✓
Door Tissue (as required)	✓	✓	✓	✓	✓	✓		
Mirror	✓	✓	✓	✓	✓	✓	✓	✓
Built-in Counter (incl. mirror + counter)	✓	✓		✓	✓		✓	✓
Shelf (adjacent to sink / toilet)			✓			✓		
Air Freshener	✓	✓	✓	✓	✓	✓	✓	✓
Baby Changing Station	✓	✓	✓					
Folding Shower Seat (as required by code)							✓	✓
Recessed in-Shower Soap Shelf							✓	✓
Towel Hook							✓	✓
Notes: 1. If All-in-One Toilet Accessory Dispenser is not used. 2. If All-in-One Sink Assembly is not used. 3. Placement of waste receptacles should be evaluated for ADA compliance, anticipated waste capacity and whether paper towel dispensers with integral waste receptacles that may already be provided.								

T1. TOILET PARTITIONS						
Image	Description	Manuf.	Model/Finish	Clinical	Non-Clinical	
T1a		Toilet Partitions	Bradley	Series 700 / #4 Satin Brushed Stl Stl	*	*
		Location: <u>Multi-stall Restrooms</u> Remarks: Floor-to-ceiling mount w/ continuous hinges, and heavy duty stainless steel hardware and locking mechanisms; provide ¼” gap max. between partitions and doors or continuous trim to cover gaps >¼”; coor’d reinforced panels w/mfr when mounting grab bars onto partitions (CFCI)				
Image	Description	Manuf.	Model/Finish	Clinical	Non-Clinical	
T1b		Toilet Partitions	Hadrian	Elite Max / #4 Satin Brushed Stl Stl	*	*
		Location: <u>Multi-stall Restrooms</u> Remarks: Floor-to-ceiling mount w/ continuous hinges, and heavy duty stainless steel hardware and locking mechanisms; specify “no-sightline” solution to achieve no gaps between partitions and doors or at rear wall; provide 84” panels/doors; top of panels/doors shall be 7’-6” AFF w/ a 6” gap from the underside of panels/doors to finish floor (at non-ADA stalls); coor’d reinforced panels w/mfr when mounting grab bars onto partitions (CFCI)				

T2. URINAL SCREEN						
Image	Description	Manuf.	Model/Finish	Clinical	Non-Clinical	
T2a		Urinal Screens	Bradley	#4 Satin Brushed Stl Stl	*	*
		Location: <u>Multi-stall Restrooms (Men’s)</u> Remarks: Wall hung urinal screen w/ stainless steel continuous bracket (CFCI)				
Image	Description	Manuf.	Model/Finish	Clinical	Non-Clinical	
T2b		Urinal Screens	Hadrian	#4 Satin Brushed Stl Stl	*	*
		Location: <u>Multi-stall Restrooms (Men’s)</u> Remarks: 48” wall hung urinal screen w/ stainless steel continuous bracket (CFCI)				

T3. ALL-IN-ONE TOILET ACCESSORY DISPENSERS						
Image	Description	Manuf.	Model/Finish	Clinical	Non-Clinical	
T3a		All-in-One Toilet Accessory Disp	Bobrick	Varies / Satin Stainless Steel	*	*
		<p>Location: <i>Single and Multi-Stall Restrooms (Women’s & Unisex)</i></p> <p>Remarks: Vertical all-in-one toilet accessory dispenser including seat cover dispenser, napkin disposal and double roll toilet paper dispenser; provide Georgia Pacific spindle kit #50011 for facilities that use Georgia Pacific compact coreless toilet paper (CFCI)</p> <p>#B-357 – Partition-mtd., serves 2 toilet stalls (mtd. centered through partition in non-ADA stalls)</p> <p>#B-3571/35715 – Partition-mtd., serves 2 toilet stalls (mtd. w/ one side flush against partition to allow clearance for grab bars in ADA stall)</p> <p>#B-3574 /35745 – Wall recessed, not partition-mtd., serves single stall</p>				
Image	Description	Manuf.	Model/Finish	Clinical	Non-Clinical	
T3b		All-in-One Toilet Accessory Disp	Bobrick	Varies / Satin Stainless Steel	*	*
		<p>Location: <i>Multi-Stall Restrooms (Men’s)</i></p> <p>Remarks: Vertical all-in-one toilet accessory dispenser including seat cover dispenser and double roll toilet paper dispenser; provide Georgia Pacific spindle kit #50011 for facilities that use Georgia Pacific compact coreless toilet paper (CFCI)</p> <p>#B-347 – Partition-mtd., serves 2 toilet stalls (mtd. centered through partition in non-ADA stalls)</p> <p>#B-3471/34715 – Partition-mtd., serves 2 toilet stalls (mtd. w/ one side flush against partition to allow clearance for grab bars in ADA stall)</p> <p>#B-3474/34745 – Wall recessed, not partition-mtd., serves single stall</p>				
Image	Description	Manuf.	Model/Finish	Clinical	Non-Clinical	
T3c		All-in-One Toilet Accessory Disp	Bobrick	Varies / Satin Stainless Steel	*	*
		<p>Location: <i>Single and Multi-Stall Restrooms (Women’s & Unisex)</i></p> <p>Remarks: Horizontal all-in-one toilet accessory dispenser including seat cover dispenser, napkin disposal and double roll toilet paper dispenser; provide Georgia Pacific spindle kit #50011 for facilities that use Georgia Pacific compact coreless toilet paper (CFCI)</p> <p>#B-3091/3092 – Wall recessed, serves single stall</p> <p>#B-30919/30929 – Surface mounted, serves single stall</p>				
<p>Notes:</p> <ol style="list-style-type: none"> Coordinate use of this item with Environmental Services / Building Services and RED+F PM. If used, individual toilet paper dispenser, sanitary napkin disposal and toilet seat cover dispenser are not required. 						

T4. TOILET PAPER DISPENSERS						
Image	Description	Manuf.	Model/Finish	Clinical	Non-Clinical	
T4a		Toilet Paper Disp. / Sanitary Disposal	Bobrick	B-3094 / Satin Stainless Steel	*	*
		Location: <u>Single and Multi-Stall Restrooms (Women’s & Unisex)</u> Remarks: Recessed, double roll toilet paper dispenser and sanitary napkin disposal unit; provide Georgia Pacific spindle kit #50011 for facilities that use Georgia Pacific compact coreless toilet paper (CFCI)				
Image	Description	Manuf.	Model/Finish	Clinical	Non-Clinical	
T4b		Toilet Paper Dispenser (Double)	Bobrick	B-386 / Satin Stainless Steel	*	*
		Location: <u>Multi-Stall Restrooms</u> Remarks: Partition mounted, dual-sided, multi-roll toilet paper dispenser; serves 2 toilet compartments; provide Georgia Pacific spindle kit #50011 for facilities that use Georgia Pacific compact coreless toilet paper (CFCI)				
Image	Description	Manuf.	Model/Finish	Clinical	Non-Clinical	
T4c		Toilet Paper Dispenser (Double)	Bobrick	B-6997 / B-69997 Stainless Steel		*
		Location: <u>Single Stall Restrooms</u> Remarks: Side-by-side double roll toilet paper dispenser; provide Georgia Pacific spindle kit #50011 for facilities that use Georgia Pacific compact coreless toilet paper (CFCI) B-6997 – recessed B-69997 – surface mounted				
Image	Description	Manuf.	Model/Finish	Clinical	Non-Clinical	
T4d		Toilet Paper Dispenser (Double)	Georgia Pacific	56798 / Stainless Steel	*	
		Location: <u>Single Stall Restrooms</u> Remarks: Surface mounted compact side-by-side double roll toilet paper dispenser (OFCI)				





T5. SANITARY NAPKIN DISPOSAL						
	Image	Description	Manuf.	Model/Finish	Clinical	Non-Clinical
T5a		Sanitary Napkin Disposal	Bobrick	B-4353 / B-4354 Satin Stainless Steel	*	*
		Location: <u>Single and Multi-stall Restrooms (Women’s & Unisex)</u> Remarks: B-4353 – Recessed sanitary napkin disposal w/ self-closing door (CFCI) B-4354 – Partition-mounted sanitary napkin disposal w/ self-closing door; mounted back-to-back to serve 2 compartments (CFCI)				
	Image	Description	Manuf.	Model/Finish	Clinical	Non-Clinical
T5b		Sanitary Napkin Disposal	Bobrick	B-354 / B-35303 Satin Stainless Steel	*	*
		Location: <u>Single and Multi-stall Restrooms (Women’s & Unisex)</u> Remarks: B-35303 – Recessed sanitary napkin disposal (CFCI) B-354 – Partition-mounted sanitary napkin disposal; mounted back-to-back to serve 2 compartments (CFCI)				
	Image	Description	Manuf.	Model/Finish	Clinical	Non-Clinical
T5c		Sanitary Napkin Disposal	Bobrick	B-270 / Satin Stainless Steel	*	*
		Location: <u>Single and Multi-stall Restrooms (Women’s & Unisex)</u> Remarks: Surface mounted sanitary napkin disposal (CFCI)				





T6. TOILET SEAT COVER DISPENSERS						
	Image	Description	Manuf.	Model/Finish	Clinical	Non-Clinical
T6a		Toilet Seat Cover Dispenser	Bobrick	B-221 / B-3013 Satin Stainless Steel	*	*
		Location: <u>Restrooms</u> Remarks: B-221 – Surface mounted toilet seat cover dispenser (CFCI) B-3013 – Recessed toilet seat cover dispenser (CFCI)				

T7. GRAB BARS						
Image	Description	Manuf.	Model/Finish	Clinical	Non-Clinical	
T7a		Grab Bars	Bobrick	B-6806 / Satin Stainless Steel	*	*
		Location: <u>Restrooms / Tubs / Showers</u>		B-68137 / Satin Stainless Steel	*	*
		Remarks: Stainless steel grab bars w/ concealed mounting flanges and snap flange covers; shapes and sizes vary (CFCI)		B-6861 / Satin Stainless Steel	*	
				B-68616 / Satin Stainless Steel	*	

T8. COAT HOOKS						
Image	Description	Manuf.	Model/Finish	Clinical	Non-Clinical	
T8a		Coat Hook (Single)	Bradley	B-9114 / Satin Stainless Steel	*	*
		Location: <u>Restrooms</u> Remarks: Surface mounted single hook; center on door; provide vandal resistant escutcheons (CFCI) Counts and mounting heights as follows: Non-ADA Toilet Stalls or Restrooms - (1) at 64" AFF ADA Toilet Stalls or Restrooms - (1) at 48" AFF and (1) at 64" AFF				

T9. SOAP DISPENSERS						
Image	Description	Manuf.	Model/Finish	Clinical	Non-Clinical	
T9a		ES8 Purell Healthy Soap Dispenser (Hands Free)	Gojo	7730-01 / White Finish	*	*
		Location: <u>Restrooms / Handwash Areas</u> Remarks: Surface mounted, touchfree, foam soap dispenser w/ "Energy on the Refill"; provide Shield Protector #7745-WHT-18; ADA-compliant when properly installed (OFCl) Purell Healthcare Healthy Soap Gentle & Free Foam Refill #7772-02				
Notes: 1. When All-in-One Sink Assembly is used, separate soap dispenser is not required. See Plumbing Fixture subsection in these Design Guidelines for further information.						

T10. HAND DRYERS						
	Image	Description	Manuf.	Model/Finish	Clinical	Non-Clinical
T10 a		Hand Dryer	Palmer	Blustorm 2 HD 0955-09 / Brushed Stainless Steel	*	*
		Location: <u>Restrooms</u> Remarks: Automatic, touchless, recessed, hand dryer made of stainless steel (CFCI) Note: All hand dryers to be mounted no further than 24" away from edge of sink.				
	Image	Description	Manuf.	Model/Finish	Clinical	Non-Clinical
T10 b		Hand Dryer	Dyson	Airblade V / Sprayed Nickel	*	*
		Location: <u>Restrooms</u> Remarks: Automatic, touchless, surface mounted, hand dryer made of molded plastic; 4" projection (CFCI) Note: All hand dryers to be mounted no further than 24" away from edge of sink.				
	Image	Description	Manuf.	Model/Finish	Clinical	Non-Clinical
T10 c		Hand Dryer	Bobrick	B-7128 / No.4 Satin Stl / Stl w/ black trim	*	*
		Location: <u>Restrooms</u> Remarks: Automatic, touchless, surface mounted, hand dryer w/ satin stainless steel cover and black trim; 4" projection (CFCI) Note: All hand dryers to be mounted no further than 24" away from edge of sink.				
	Image	Description	Manuf.	Model/Finish	Clinical	Non-Clinical
T10 d		Hand Dryer	Toto	HDR111#SS / Stainless Steel	*	*
		Location: <u>Restrooms</u> Remarks: Automatic, touchless, recessed, hand dryer w/ stainless steel cover. (CFCI) Note: All hand dryers to be mounted no further than 24" away from edge of sink.				
Notes: 1. When an All-in-One Sink Assembly is used, separate hand dryer is not required. See Plumbing Fixture subsection in these Design Guidelines for further information.						

T11. PAPER TOWEL DISPENSERS						
	Image	Description	Manuf.	Model/Finish	Clinical	Non-Clinical
T11 a	 **Preferred**	Paper Towel Dispenser	Georgia Pacific	59466A / Stainless Steel	*	*
		Location: <u>Restrooms / Exam Rooms / Handwash Areas</u> Remarks: Semi-recessed automatic touchless paper towel dispenser. Hardwired Installation is preferred. Separate transformer kit is required. Consult w/ RED+F for transformer kit model #. Compatible w/ waste receptacle T12a (OFCI) (Approval by RED+F Senior Leadership required.)				
	Image	Description	Manuf.	Model/Finish	Clinical	Non-Clinical
T11 b		Paper Towel Dispenser	Bobrick	B-359033 / Satin Stainless Steel	*	*
		Location: <u>Exam Rooms / Handwash Areas</u> Remarks: Recessed manual paper towel dispenser with lock and key; specify with TowelMate 369-130 (CFCI) (Approval by RED+F Senior Leadership required.)				
	Image	Description	Manuf.	Model/Finish	Clinical	Non-Clinical
T11 c		Paper Towel Dispenser	Bobrick	B-359039 / Satin Stainless Steel	*	*
		Location: <u>Exam Rooms / Handwash Areas</u> Remarks: Surface mounted manual paper towel dispenser with lock and key; specify with TowelMate 369-130 (CFCI) (Approval by RED+F Senior Leadership required.)				
	Image	Description	Manuf.	Model/Finish	Clinical	Non-Clinical
T11 d		Recessed Paper Towel Dispenser	Bobrick	B-318 / Stainless Steel	*	
		Location: <u>Exam Rooms / Handwash Areas</u> Remarks: Recessed paper towel dispenser to be concealed within millwork (CFCI)				











T12. WASTE RECEPTACLES						
	Image	Description	Manuf.	Model/Finish	Clinical	Non-Clinical
T12 a	 **Preferred**	Waste Receptacle (for enMotion)	Georgia Pacific	enMotion Series / Satin Stainless Steel	*	*
		Location: <u>Restrooms / Handwash Areas</u> Remarks: Semi-recessed integral waste receptacle compatible with automatic paper towel dispenser T11a; model #59491 is preferred (11-gallon capacity); other models are available to coordinate with varying stud spacing (OFCI) (Approval by RED+F Senior Leadership required.)				

Image		Description	Manuf.	Model/Finish	Clinical	Non-Clinical
T12 b		Waste Receptacle	Bobrick	B-3644 / Satin Stainless Steel	*	*
		Location: <u>Restrooms / Handwash Areas (trash only)</u> Remarks: 12-gal recessed waste receptacle; specify w/ LinerMate #3944-134 (CFCI) Dimensions – 8-1/8”D x 15-3/16”W x 28-5/8”H (w/ 1” trim)				
Image		Description	Manuf.	Model/Finish	Clinical	Non-Clinical
T12 c		Trash Receptacle (Rectangular)	Rubbermaid	FGSR18SSPL / Stl Stl	*	*
		Location: <u>Restrooms (trash only)</u> Remarks: 22.5-gal freestanding, open top, trash receptacle w/ plastic liner, made from heavy-gauge, fire-safe steel (OFCl) Dimensions – 12.01”D x 24.02”W x 30.35”H				
Image		Description	Manuf.	Model/Finish	Clinical	Non-Clinical
T12 d		Trash Receptacle (Square)	Rubbermaid	Square Open Top / Silhouette / Stl Stl	*	*
		Location: <u>Restrooms (trash only)</u> Remarks: Freestanding, open top, trash receptacle w/ plastic liner, made from heavy-gauge, fire-safe steel (OFCl) #FGSC14SSPL – 16 gal. capacity; 14.76”D x 14.76”L x 30.35”H #FGSC18SSPL – 20 gal. capacity; 18.39”D x 18.39”W x 30.35”H				
Image		Description	Manuf.	Model/Finish	Clinical	Non-Clinical
T12 e		Trash Receptacle (Half-Round)	Rubbermaid	FGSH12SSPL / Stainless Steel	*	*
		Location: <u>Restrooms (trash only)</u> Remarks: 12-gal freestanding, open top, half round trash receptacle w/ plastic liner; no plastic bag option available; made from heavy-gauge, fire-safe steel; fits against walls to conserve space (OFCl) Dimensions – 8.8”D x 17.6”W x 32.40”H				
Image		Description	Manuf.	Model/Finish	Clinical	Non-Clinical
T12 f		Waste Receptacle	Bobrick	Varies / Stainless Steel	*	*
		Location: <u>Baby Changing (trash only)</u> Remarks: 3-gal recessed waste receptacle w/ flap (CFCl) #B-35633 – recessed (0.75” protrusion) #B-35639 – surface mounted (4.5” D)				

T13. DOOR TISSUE						
Image	Description	Manuf.	Model/Finish	Clinical	Non-Clinical	
T13 a 	Door Tissue	Georgia Pacific	Safe-T-Gard Dispenser / Stainless Steel	*	*	
	Location: <u>Restrooms</u> Remarks: Surface mounted toilet door tissue dispenser; mount near toilet room exit door; (OFCl) #59503 (Door tissue dispenser only; w/ freestanding waste receptacle below)					
Notes: 1. Provide door tissue only when paper towel dispenser (w/ waste receptacle) cannot be located near restroom door.						

T14. MIRRORS						
Image	Description	Manuf.	Model/Finish	Clinical	Non-Clinical	
T14 a 	Mirror	Electric Mirror	Fusion Lighted Mirror FUS – size varies		*	
	Location: <u>Restrooms</u> Remarks: Surface mounted lighted mirror; size varies; electrical power should be controlled by light switch (CFCl)					
Image	Description	Manuf.	Model/Finish	Clinical	Non-Clinical	
T14 b 	Frameless Mirror	Custom	Custom	*	*	
	Location: <u>Restrooms</u> Remarks: Frameless mirror, sizes and configurations vary, frameless glass to be flush w/ tile and installed prior to tile (CFCl)					
Image	Description	Manuf.	Model/Finish	Clinical	Non-Clinical	
T14 c 	Framed Mirror	Bradley	781 / Bright Annealed Stainless Steel	*	*	
	Location: <u>Back of House Restrooms / Staff Locker Rooms</u> Remarks: Surface mounted mirror w/ roll-formed channel frame and theft-resistant mounting; sizes vary (CFCl) Note: To be used only when frameless mirror is not feasible.					
Notes: 1. ADA mirrors shall be specified with the bottom of the <i>reflective surface</i> at 40" AFF, not the mirror frame.						









T15. SHELVES						
Image		Description	Manuf.	Model/Finish	Clinical	Non-Clinical
T15 a		Glass Shelf	HEWI	800.03.10045 / Chrome	*	*
		Location: <u>Single Stall Restrooms</u> Remarks: Surface mounted shelf with satin glass. 23.62" long x 0.78" high x 3.93" deep. Provide adjacent to sink / toilet. Review and approval by RED+F required. (CFCI)				
Image		Description	Manuf.	Model/Finish	Clinical	Non-Clinical
T15 b		Glass Shelf	HEWI	162.03.1005XA / Satin 162.03.100540 / Chrome	*	*
		Location: <u>Single Stall Restrooms</u> Remarks: Surface mounted shelf with satin glass. 17.71" long x 4.8" deep. Provide adjacent to sink / toilet. Review and approval by RED+F required. (CFCI)				
Image		Description	Manuf.	Model/Finish	Clinical	Non-Clinical
T15 c		Metal Shelf	ASI	0412-M-1814 / Stainless Steel	*	*
		Location: <u>Single Stall Restrooms</u> Remarks: Recessed stainless steel shelf. Internal dimensions at 12" high x 16" wide x 4" deep. Provide adjacent to sink / toilet. Review and approval by RED+F required. (CFCI)				
Image		Description	Manuf.	Model/Finish	Clinical	Non-Clinical
T15 d		Metal Shelf	Bradley	9094 / Satin Stainless Steel	*	*
		Location: <u>Single Stall Restrooms</u> Remarks: Surface mounted, 6-1/4" mounting bracket depth with 5" deep shelf, lengths vary (18"/24"/30"). Provide adjacent to sink / toilet. Review and approval by RED+F required. (CFCI)				
Image		Description	Manuf.	Model/Finish	Clinical	Non-Clinical
T15 e		Metal Shelf	Bobrick	B-683 X 24 / Satin Stainless Steel	*	*
		Location: <u>Single Stall Restrooms</u> Remarks: Surface mounted, 5-3/4" mounting bracket depth with 4-3/4" deep shelf, 24" length. Provide adjacent to sink / toilet. Review and approval by RED+F required. (CFCI)				

Image		Description	Manuf.	Model/Finish	Clinical	Non-Clinical
T15 f		Metal Shelf	ASI	20692-6XX / Stainless Steel	*	*
		Location: <u>Single Stall Restrooms</u> Remarks: Surface mounted, 6" deep shelf of varying lengths. Provide adjacent to sink / toilet. Review and approval by RED+F required. (CFCI)				

T16. AIR FRESHNERS						
Image		Description	Manuf.	Model/Finish	Clinical	Non-Clinical
T16 a		Air Freshener	Georgia Pacific	ActiveAire #53258A / Stainless Steel	*	*
		Location: <u>Restrooms</u> Remarks: Surface mounted, whole-room, battery-operated air freshener dispenser; to be mounted with bottom at a min. 7'-0" AFF (OFCI)				

T17. BABY CHANGING STATIONS						
Image		Description	Manuf.	Model/Finish	Clinical	Non-Clinical
T17 a		Baby Changing Station	Foundations	Premier / Stainless Steel	*	*
		Location: <u>Restrooms</u> Remarks: Horizontal, recessed, stainless steel baby changing station (CFCI). Locate within ADA stall wherever possible. Provide trash receptacle T12e adjacent to baby changing stations. (CFCI)				







T18. SHOWER ACCESSORIES						
Image		Description	Manuf.	Model/Finish	Clinical	Non-Clinical
T18 a		Folding Shower Seat	Bradley	9562 / 9569 White Phenolic Seat, Stl Stl Frame	*	*
		Location: <u>Showers (as required by code)</u> Remarks: 9562 – Folding shower seat, ADA-compliant (CFCI) 9569 – Reversible folding shower seat, ADA-compliant (CFCI)				

Image		Description	Manuf.	Model/Finish	Clinical	Non-Clinical
T18 b		Pre-fab Shower Niche (Tiled)	Schluter	KB 12 SN 305 305A / Tile Ready	*	*
		Location: <u>Showers</u> Remarks: Prefabricated shower niche for tile over applications made of KERDIBOARD that can be installed in both KERDI and KERDI-BOARD wall assemblies; 12” x 12” single niche; Review and approval by RED+F required. (CFCI)				
Image		Description	Manuf.	Model/Finish	Clinical	Non-Clinical
T18 c		Pre-fab Shower Niche (Tiled)	Tile Redi	Redi Niche / Tile Ready	*	*
		Location: <u>Showers</u> Remarks: Prefabricated shower niche for tile over applications; single niche configuration preferred; standard and custom sizes available; Review and approval by RED+F required. (CFCI)				
Image		Description	Manuf.	Model/Finish	Clinical	Non-Clinical
T18 d		Pre-fab Shower Niche (Stl. Stl.)	Redblock	N1014 / Stainless Steel	*	*
		Location: <u>Showers</u> Remarks: Prefabricated stainless steel shower niche with perforated soap shelf; Review and approval by RED+F required. (CFCI)				
Image		Description	Manuf.	Model/Finish	Clinical	Non-Clinical
T18		Towel Hook (Single)	Bradley	9314 / Satin Stainless Steel		*
		Location: <u>Showers</u> Remarks: Surface mounted single hook; provide vandal resistant escutcheons (CFCI) Counts and mounting heights as follows: Non-ADA Shower Stalls - (1) at 64” AFF ADA Shower Stalls - (1) at 48” AFF and (1) at 64” AFF				
Image		Description	Manuf.	Model/Finish	Clinical	Non-Clinical
T18 f		Towel Bar	Kohler	K-26634-CP / Polished Chrome		*
		Location: <u>Showers</u> Remarks: 24” surface mounted towel bar; center on door; provide vandal resistant escutcheons (CFCI)				
Notes: 1. Refer to the Material Legend subsection of these Design Guidelines for information on shower curtains and related hardware.						

T19. MOP AND BROOM HOLDER						
	Image	Description	Manuf.	Model/Finish	Clinical	Non-Clinical
T19 a		Mop and Broom Holder	Bradley	9953 / 9954 / 9955 Satin Stainless Steel	*	*
		Location: <u>Janitor's Closet</u> Remarks: 9953 – Surface mtd mop and broom holder w/ (3) holders, 24" long (CFCI) 9954 – Surface mtd mop and broom holder w/ (4) holders, 36" long (CFCI) 9955 – Surface mtd mop and broom holder w/ (5) holders, 48" long (CFCI)				

BUILDING ACCESSORIES

In order to create and maintain a consistent brand and allow appropriate maintenance at NYU Langone Health spaces, specific building accessories are used. The list below will give the A/E Team a sense of the typical items used throughout NYU Langone facilities. It is the Architect’s responsibility to select items that are code compliant and appropriate for the capital project based on the type of space and end-user needs. The Architect and Interior Designer shall consider specifying existing building-specific standards provided they are in line with these Design Guidelines. Architects shall coordinate with the RED+F Project Manager, Facilities Operations and the Design Studio to finalize product selections. Please note the following items are preferred over others:

- Recessed accessories are preferable where possible.

Abbreviations

- OFCI: Owner-Furnished, Contractor-Installed
- CFCI: Contractor-Furnished, Contractor-Installed

The product specifications included in this subsection are organized by type as follows:

- B1. Purell / Soap Dispensers and Stands
- B2. Coat Hooks
- B3. Paper Towel Dispensers
- B4. Laundry Grommets
- B5. Umbrella Stand
- B6. Fire Extinguisher Cabinets
- B7. Clocks
- B8. Bike Racks
- B9. Emergency Call Station



B1. PURELL / SOAP DISPENSERS AND STANDS						
	Image	Description	Manuf.	Model/Finish	Clinical	Non-Clinical
B1a		Purell Floor Stand (w/ ES8 Disp.)	Gojo	#7308-DS-SLV / Silver Panel	*	*
<p>Location: <u>Public Areas</u></p> <p>Remarks: Floor stand for ES8 Purell Dispensers w/ “Energy-on-the-Refill”. Not to be located on carpet. Stand comes w/ White PURELL ES8 PURELL Dispenser w/ Shield Protector.(OFCI) For Replacement Dispenser and Protector Shield info see B1b below. Purell Healthcare Advanced Hand Sanitizer Foam Refill #7753-02</p>						

Image	Description	Manuf.	Model/Finish	Clinical	Non-Clinical
	Purell ES8 Dispenser w/ Shield Protector	Gojo	#7720-01 / White Finish	*	*
	Location: <u>Public Areas / Exam Rooms / Patient Rooms</u> Remarks: PURELL ES8 Dispenser w/ “Energy on the Refill” for use as replacement on floor stand B1a or to be wall mounted to coordinate w/ nearby B1a floor stand mounted dispensers. Provide w/ Shield Protector #7745-WHT-18. Not to be located over carpet. (OFCl) Purell Healthcare Advanced Hand Sanitizer Foam Refill #7753-02				
Image	Description	Manuf.	Model/Finish	Clinical	Non-Clinical
	ES8 Purell Healthy Soap Dispenser (Hands Free)	Gojo	7730-01 / White Finish	*	*
	Location: <u>Lactation Rooms</u> Remarks: Surface mounted, touchfree, foam soap dispenser w/ “Energy on the Refill”; provide Shield Protector #7745-WHT-18; ADA-compliant when properly installed (OFCl) Purell Healthcare Healthy Soap Gentle & Free Foam Refill #7772-02				





B2. COAT HOOKS					
Image	Description	Manuf.	Model/Finish	Clinical	Non-Clinical
	Coat Hook (Single)	Bradley	9114 / Satin Stainless Steel		*
	Location: <u>Private Office / Exam Room / Changing Room / Lactation and Wellness Rooms, etc.</u> Remarks: Surface mounted single hook; locate (1) on back of Private Office doors at 64” AFF (2) on back of all other doors, (1) at 48” AFF and (1) at 64” AFF (CFCl)				
Image	Description	Manuf.	Model/Finish	Clinical	Non-Clinical
	Coat Hook (Single)	Peter Pepper	2015 / Varies (see below)		*
	Location: <u>Private Office / Exam Room / Changing Room / Lactation and Wellness Rooms, etc.</u> Remarks: Surface mounted single hook. Wood screws included. For wall mounting spec w/ wall anchor #2999 (natural anodized alum); locate (1) on back of Private Office doors at 64” AFF (2) on back of all other doors, (1) at 48” AFF and (1) at 64” AFF (CFCl) #2015H – Polished Chrome #2015SH – Satin Chrome				

Image	Description	Manuf.	Model/Finish	Clinical	Non-Clinical
	Coat Hook (Single)	Peter Pepper	2024 / Varies (see below)		*
	Location: <i>Private Office</i> Remarks: Surface mounted single hook. Wood screws included. For wall mounting spec w/ wall anchor #2999 (natural anodized alum). Locate (1) on back of door at 64" AFF (CFCI) #2024AL – Polished Aluminum, Natural Anodized #2024H – Polished Chrome				
Image	Description	Manuf.	Model/Finish	Clinical	Non-Clinical
	Coat Hook (Single)	Peter Pepper	2026 / Varies (see below)		*
	Location: <i>Private Office</i> Remarks: Surface mounted single hook. Wood screws included. For wall mounting spec w/ wall anchor #2999 (natural anodized alum). Locate (1) on back of door at 64" AFF (CFCI) #2026AL – Polished Aluminum, Natural Anodized #2026H – Polished Chrome				
Image	Description	Manuf.	Model/Finish	Clinical	Non-Clinical
	Coat Hook w/ Door Stop (Single)	Peter Pepper	2083 / Polished Alum., Natural Anodized		*
	Location: <i>Private Office</i> Remarks: Surface mounted single hook w/ rubber door stop tip. Wood screws included. For wall mounting spec w/ wall anchor #2999 (natural anodized alum). Locate (1) on back of door at 64" AFF (CFCI)				
Image	Description	Manuf.	Model/Finish	Clinical	Non-Clinical
	Coat Hooks (Multiple)	Peter Pepper	2043 / 2043XL Natural Anodized Alum.	*	*
	Location: <i>Back-of-House / Staff Locker Rooms</i> Remarks: Locate (1) at 48" AFF and (1) at 64" AFF (CFCI) 2043 – (3) hooks on flush plate; surface mounted 2043XL – (4) hooks on flush plate; surface mounted				







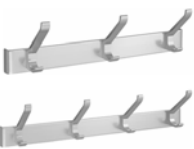

B3. PAPER TOWEL DISPENSERS					
Image	Description	Manuf.	Model/Finish	Clinical	Non-Clinical
	Paper Towel Dispenser	TrippNT	Varies / clear acrylic		*
	Location: <i>Pantry / Lactation Room</i> Remarks: Commercial grade, surface mounted paper towel dispenser for multi and c-fold paper towels (CFCI) #51912 – Small capacity; 10-7/8"W x 6-1/2"H x 4-1/4"D #51935 – Large capacity; 10-7/8"W x 14-1/2"H x 4-3/8"D				

Image		Description	Manuf.	Model/Finish	Clinical	Non-Clinical
B3b		Paper Towel Dispenser	Georgia Pacific	59466A / Stainless Steel	*	
		Location: <u>Pantry / Lactation Room</u> Remarks: Semi-recessed automatic touchless paper towel dispenser. Hardwired Installation is preferred. Separate transformer kit is required. Consult w/ RED+F for transformer kit model #. (Approval by RED+F Senior Leadership required.) (CFCl)				
Image		Description	Manuf.	Model/Finish	Clinical	Non-Clinical
B3c		Paper Towel Dispenser	Bobrick	B-359033 / Satin Stainless Steel		*
		Location: <u>Pantry / Lactation Room</u> Remarks: Manual paper towel dispenser; recessed with lock and key; specify w/ TowelMate 369-130 (CFCl)				
Image		Description	Manuf.	Model/Finish	Clinical	Non-Clinical
B3d		Paper Towel Dispenser	Bobrick	B-359039 / Satin Stainless Steel	*	*
		Location: <u>Pantry / Lactation Room</u> Remarks: Surface mounted manual paper towel dispenser with lock and key; specify with TowelMate 369-130 (CFCl) (Approval by RED+F Senior Leadership required.)				
Image		Description	Manuf.	Model/Finish	Clinical	Non-Clinical
B3e		Paper Towel Dispenser	TrippNT	52916 / clear acrylic		*
		Location: <u>Pantry / Lactation Room</u> Remarks: Commercial grade, countertop paper towel dispenser for multi and c-fold paper towels; w/ clear rubber feet on bottom; 11" x 5" x 7" (CFCl)				
Image		Description	Manuf.	Model/Finish	Clinical	Non-Clinical
B3f		Paper Towel Dispenser	Tork	302030 / Stainless Steel		*
		Location: <u>Pantry / Lactation Room</u> Remarks: Commercial grade, freestanding paper towel dispenser for multi paper towels (CFCl)				

B4. LAUNDRY GROMMETS						
Image		Description	Manuf.	Model/Finish	Clinical	Non-Clinical
B4a		Laundry Grommet (Round)	Doug Mockett	TM2C / Satin Stainless Steel	*	*
		Location: <u>Built-in Laundry Receptacles</u> Remarks: 8" dia. X 3" deep trash grommet (CFCI)				
Image		Description	Manuf.	Model/Finish	Clinical	Non-Clinical
B4b		Laundry Chute (Square)	Doug Mockett	TM2A/SQ Satin Stainless Steel	*	*
		Location: <u>Built-in Laundry Receptacles</u> Remarks: 8" square x 6" deep trash grommet (CFCI)				

B5. UMBRELLA STAND						
Image		Description	Manuf.	Model/Finish	Clinical	Non-Clinical
B5a		Umbrella Stand	Brenmar Co.	340016 / Satin Stainless Steel		*
		Location: <u>Near exterior entry doors</u> Remarks: Dual umbrella wrapper stand (CFCI)				







B6. FIRE EXTINGUISHER CABINETS						
Image		Description	Manuf.	Model/Finish	Clinical	Non-Clinical
B6a		Fire Extinguisher Cabinet	JL Industries	Embassy Series / #4 Stl. Stl. or Painted *	*	*
		Location: <u>Locate as required by code and NYULH Safety Policy 116 (except at Behavioral Health / Psychiatric Areas)</u> Remarks: Trimless recessed cabinet w/ std. painted white interior; door on concealed hinges projects 7/8" beyond face of adjacent wall; provide w/ clear acrylic vertical duo panel, zinc pull and no lock; ADA compliant when properly installed; stainless steel door finish typical (CFCI) *Painted door finish to match adjacent wall color is acceptable under certain design conditions only and requires RED+F approval.				

Image	Description	Manuf.	Model/Finish	Clinical	Non-Clinical
	Fire Extinguisher Cabinet	Larsen	Occult Series / #4 Stl. Stl. or Painted *	*	*
	<p>Location: <u>Locate as required by code and NYULH Safety Policy 116 (except at Behavioral Health / Psychiatric Areas)</u></p> <p>Remarks: Trimless recessed cabinet w/ std. painted white interior; door on concealed hinges projects 5/8" beyond face of adjacent wall; provide w/ clear acrylic vertical duo panel, zinc pull and no lock; ADA compliant when properly installed; stainless steel door finish typical (CFCI) *Painted door finish to match adjacent wall color is acceptable under certain design conditions only and requires RED+F approval.</p>				
Image	Description	Manuf.	Model/Finish	Clinical	Non-Clinical
	Fire Extinguisher Cabinet	JL Industries	Cosmopolitan Series / #4 Stl. Stl.	*	*
	<p>Location: <u>Locate as required by code and NYULH Safety Policy 116 in Behavioral Health / Psychiatric Areas</u></p> <p>Remarks: Trimless recessed cabinet w/ std. painted white interior; door on continuous hinges flush w/ face of adjacent wall; provide w/ clear acrylic vertical duo panel, recessed pull and mortise lock w/ keyed cylinder; ADA compliant when properly installed (CFCI)</p>				
Image	Description	Manuf.	Model/Finish	Clinical	Non-Clinical
	Fire Extinguisher Cabinet	Larsen	Architectural Series / #4 Stl. Stl.	*	*
	<p>Location: <u>Locate as required by code and NYULH Safety Policy 116 in Behavioral Health / Psychiatric Areas</u></p> <p>Remarks: Trimless recessed cabinet w/ std. painted white interior; door on continuous hinges projects 5/16" beyond face of adjacent wall; provide w/ clear acrylic vertical duo panel, recessed pull and mortise lock w/ keyed cylinder; ADA compliant when properly installed (CFCI)</p>				
<p>Notes:</p> <ol style="list-style-type: none"> Fire extinguisher cabinets shall: <ul style="list-style-type: none"> - be able to house the appropriate type and size fire extinguisher specified without modification, - be fully recessed (wherever possible), - maintain the fire rating of the wall within which they are installed, - have concealed hinges, - have a clear polycarbonate vertical window panel, - have doors that open by simply pulling on the handle, - have doors that latch shut without the use of a key, and - have handles/pulls that are located in an ADA-compliant manner. Fire extinguisher cabinets shall NOT: <ul style="list-style-type: none"> - have break-glass, or - protrude more than 4" beyond the face of the wall when semi-recessed. Behavioral health / psychiatric areas shall meet all of the above specifications, except they shall: <ul style="list-style-type: none"> - have continuous hinges, - have cabinets specified with a mortise lock with keyed cylinder and - have fully recessed cabinet pulls. Refer to the Miscellaneous subsection of these Design Guidelines for further information. 					

B7. CLOCKS					
Image	Description	Manuf.	Model/Finish	Clinical	Non-Clinical
 **Preferred**	Digital Clock	Sapling	SBP-31F-404-0W		*
	Location: <u>Conference Rooms</u> Remarks: SBP 3000 Series Digital IP Clock (V1.2); 4-digit flush mounted digital clock w/ 4" white digits and feature set 3100; 12-hour / 50% dimmed; Sapling Synchronized Clock System is required for tie-in (CFCI)				
Image	Description	Manuf.	Model/Finish	Clinical	Non-Clinical
	Analog Clock	Sapling	Varies / Brushed Alum.	*	
	Location: <u>Patient Rooms</u> Remarks: Analog 12" clock w/ brushed alum. frame; Dial Z, and Special Hand Option 1. Confirm power and connection type (battery, wireless, talkback wireless, IP, or wired) as well as mounting with RED+F PM. (CFCI)				





B8. BIKE RACKS					
Image	Description	Manuf.	Model/Finish	Clinical	Non-Clinical
	Bike Rack	Varies	Metro / Electro Polished Stainless Steel		*
	Location: <u>Outdoor Bike Parking</u> Remarks: electro polished stainless steel bike rack; 2-bike capacity per rack; rack can be installed in series to accommodate additional bikes (Approval by RED+F Senior Leadership required.) (CFCI) #MET-2-IG-ES – In-ground mount #MET-2-SF-ES – Surface mount				
Image	Description	Manuf.	Model/Finish	Clinical	Non-Clinical
	Bike Rack	Varies	Opal / Electro Polished Stainless Steel		*
	Location: <u>Outdoor Bike Parking</u> Remarks: electro polished stainless steel bike rack; 2-bike capacity per rack; rack can be installed in series to accommodate additional bikes; 1-5/8" dia. tube; 28" high (Approval by RED+F Senior Leadership required.) (CFCI) #OPR-2-IG-ES – In-ground mount #OPR-2-SF-ES – Surface mount				

Image	Description	Manuf.	Model/Finish	Clinical	Non-Clinical
	Bike Rack	Varies	Winder Plus / Stainless Steel		*
	<p>Location: <u>Outdoor Bike Parking</u> Remarks: stainless steel bike rack; 3-11 bike capacity per rack; 1-5/8" dia. tube; 36" high; 14" to 113" long depending on number of loops specified (Approval by RED+F Senior Leadership required.) (CFCI) #WP36-XX-IG-S – In-ground mount; specify # of loops where XX is shown #WP36-XX-SF-S – Surface mount; specify # of loops where XX is shown</p>				
Image	Description	Manuf.	Model/Finish	Clinical	Non-Clinical
	Bike Rack	Varies	Heavy Duty Challenger / Stainless Steel		*
	<p>Location: <u>Outdoor Bike Parking</u> Remarks: stainless steel bike rack; 3-11 bike capacity per rack; 2-3/8" dia. tube; 36" high; 18" to 113" long depending on number of loops specified (Approval by RED+F Senior Leadership required.) (CFCI) #H36-XX-IG-S – In-ground mount; specify # of loops where XX is shown #H36-XX-SF-S – Surface mount; specify # of loops where XX is shown</p>				
Image	Description	Manuf.	Model/Finish	Clinical	Non-Clinical
	Bike Rack	Varies	Challenger Plus / Stainless Steel		*
	<p>Location: <u>Outdoor Bike Parking</u> Remarks: stainless steel bike rack; 3-11 bike capacity per rack; 2-3/8" dia. tube; 36" high; 22" to 178" long depending on number of loops specified (Approval by RED+F Senior Leadership required.) (CFCI) #CHP-XX-IG-S – In-ground mount; specify # of loops where XX is shown #CHP-XX-SF-S – Surface mount; specify # of loops where XX is shown</p>				

B9. EMERGENCY CALL STATION					
Image	Description	Manuf.	Model/Finish	Clinical	Non-Clinical
	Emergency Call Station	Talkphone	Varies / Stainless Steel	*	*
	<p>Location: <u>Building Exterior / Parking Structures</u> Remarks: Emergency (blue light) call station w/ custom NYU Langone Health signage (CFCI) #ETP-WMS-OP2-NYU-LA1 – surface mounted, includes housing to mount fixed stand form CCTV camera with max. depth of 3.5" (by NYULH) #ETP-WMS-OP3IP-NYU-LA1 – surface mounted, includes AXIS M1025 network camera #ETP-MT/R-72-OP2-NYU-LA1 – pedestal mounted, includes housing to mount fixed stand form CCTV camera with max. depth of 3.5" (by NYULH); custom paint color: Tnemec Metallic color #46MT "Medium Steel" (Review by NYULH Security and Approval by RED+F Senior Leadership required.)</p>				

RECYCLING PROGRAM

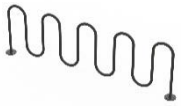
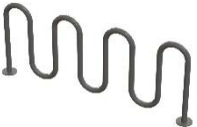
NYU Langone Health has instituted a system-wide recycling program to reduce our waste to landfill, meet our sustainability goals and comply with updated *NYC Local Law 87* rules for business recycling. We want to ensure staff, residents and visitors are able to recycle required materials, that the integrity of our recycling program is maintained and that waste and recycling are properly handled by our private carters. In line with that commitment we are providing additional information about NYU Langone’s Recycling Program organized as follows:

1. General Recycling Program Requirements
2. Specific Recycling Program Requirements
3. Signage Requirements
4. Decal Requirements
5. Locations for Trash and Recycling Receptacles
6. Trash and Recycling Receptacle Specifications

1. General Recycling Program Requirements

NYU Langone has determined that centralized sorting of trash and recyclables and movement away from individualized collection is the preferred methodology.

DSNY rule of thumb: Wherever there is a trash bin, there should also be recycling bin(s).

When specifying trash and recycling receptacles, the A/E Team shall:

- Confirm project recycling procedures, including any landlord or building requirements. NYU Langone has chosen to pursue source-separated recycling. DSNY defines source-separated recycling collection as:

“The practice of separating the two designated recyclable “streams” from each other and from garbage. These three streams must be kept separate from the point of generation (where staff/customers place an item in a receptacle) until the materials are placed out for collection. Your carter is then required to collect the three streams with three separate trucks or in three separate compartments in a truck.”

The three streams include:

- Trash | Waste | Landfill
 - Paper | Cardboard | Paperboard Recycling
 - Metals | Glass | Plastics | Beverage Cartons Recycling
- Provide adequate space on the plans for trash and recycling receptacles to be located in discreet areas (i.e. niches, alcoves, built-in millwork, etc.), but still convenient to staff and visitors.
 - Select container gallon capacities appropriate to the designation, size and type of activity occurring within the space the receptacles serve. Avoid oversized bins (i.e. **Clinical facilities shall receive receptacles that are no more than 32 gal. per container**).
 - For Storage and Hauling, the regulation makes it illegal for any hauler to collect recyclables and trash in the same truck. Therefore, the infrastructure to keep these streams separated from point of generation to hauling must be provided by NYU Langone. Project Teams must ensure adequate storage space and loading dock configuration for

separated trash and recycling. It can be in the same room or on the same dock, but must be clearly separated with its own signage and labeling. Consider predicted waste volume and the activity happening in the space.

- Helpful Resources:
 - City of New York Department of Sanitation - www1.nyc.gov/assets/dsny/site/home
 - <https://www1.nyc.gov/assets/dsny/docs/commercial-recycling-notice-english.pdf>
 - AIA “Zero Waste Design Guidelines”

2. *Specific Recycling Program Requirements*

When specifying trash and recycling receptacles, the A/E Team shall:

- For Private Offices and Work Stations, do not provide deskside bins. Should staff or departmental representatives opt to have deskside bins 1 “paper only” receptacle shall be provided under the desk. Deskside bins for items other than “paper only” are not permitted.
- For Open Work Areas:
 - Provide centralized trash and recycling receptacles placed no more than 50’-0” apart so that staff walk a maximum of 25’-0” in either direction to access the nearest receptacle.
 - Calculate the capacity using the following as a minimum guideline:
1 person = 1 gallon trash + 1 gallon metal-glass-plastic + 1 gallon paper
- Provide compost receptacles at Cafés, Cafeterias and Pantries if composting is available at the site. These receptacles shall be in addition to trash and recycling. Inclusion of a sink for disposing of liquids prior to sorting of waste is encouraged.
- For Back-of-House Areas, coordinate trash and recycling receptacle specification and locations with the Design Studio, appropriate maintenance department (i.e. Building Services, Environmental Services, etc.) and end-user during the Design Development phase.
- Trash and recycling receptacles shall be procured by the RED+F PM either as part of the furniture package or directly from an NYULH-approved commercial maintenance products vendor. While trash and recycling built into millwork is part of the millwork package it is the responsibility of the RED+F PM to procure the specified internal rigid liner. For Confidential Paper Recycling, HIPAA paper should always be kept separate for shredding as part of NYU Langone’s existing HIPAA shredding program.
- For Universal Waste Recycling, all universal waste shall be stored in accordance with EH&S safety policies and then recycled by either EH&S or MCIT.
- For Lab Glass, appropriate bins shall be made available to NYU Langone labs for lab glass collection separate from the recycling program.

3. Signage Requirements

There are a variety of different signs required for the Recycling Program at NYU Langone Health. The A/E Team and RED+F PM shall coordinate signage fabrication and installation with NYU Langone Design Studio’s Signage/Wayfinding Group as part of the capital project. The signs shall be located as follows:

- **Exterior** - Business Integrity Commission (BIC) hauler decals shall be displayed where they are visible from the outside of a building (if owned, leased by or occupied exclusively by NYU Langone) or tenant space (if leased by NYU Langone and we provide our own waste hauling). BIC decals are supplied by the contracted waste hauler. To obtain BIC decals coordinate with either Environmental Services or Building Services.

BIC decals shall be aligned to architectural elements and placed in lower corners of storefront windows away from entry doors. BIC decals shall not be placed adjacent to entry doors, unless it cannot be avoided. Recommended locations, listed in order of highest to lowest preference, are loading docks and exterior waste storage areas, exterior building entries and interior tenant entries.



- **Public Areas (w/o Composting)** - The following signage shall be posted wherever trash and recycling centers are provided. Signs shall be printed on Sintra and installed with the bottom edge 3” above the trash and recycling center’s top surface.



- Public Areas (w/ Composting)** - The following signage shall be posted wherever compost is provided in addition to trash and recycling. Signs shall be printed on Sintra and installed with the bottom edge 3” above the trash, recycling and compost center’s top surface.

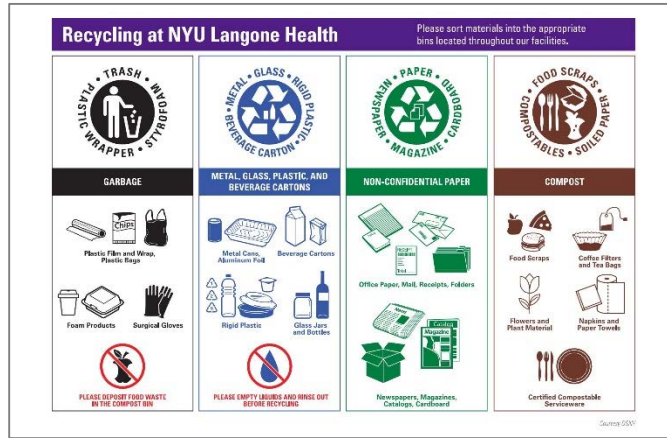

- Back-of-House Areas** - The following signage shall be posted in the back-of-house areas described below:
 - Maintenance/Storage Areas: Areas near compactors or trash and recycling front end loader (FEL) bins, or anywhere else trash and recycling bags are aggregated and stored for more than 20 minutes.
 - Loading Docks: Loading docks of buildings owned or leased by NYU Langone where there is waste hauling infrastructure or storage.



4. Decal Requirements

Decals shall be posted on each trash, metal-glass-plastic, and paper receptacle. Cafés and Cafeterias shall receive an additional decal to be posted at each compost receptacle. The A/E Team and RED+F PM shall coordinate signage fabrication and installation with NYU Langone Design Studio’s Signage/Wayfinding Group as part of the capital project. The decals shall be applied as follows:

▪ **Front-of-House Receptacles**

- Decals shall be 4-1/2” in diameter.
- Each decal shall be centered on and located directly below its respective opening.
- Decals shall be black (trash), blue (metal-glass-plastic), green (paper), or brown (compost in Cafés, Cafeterias and Pantries only) cut vinyl.



Cafés / Cafeterias / Pantries (if required)

▪ **Back-of-House Receptacles**

- Decals shall be 3” in diameter on the short side and 5” in diameter on the long side.
- Decals shall be centered horizontally on each side of the Slim Jim. The heights of the decals measured from the bottom of the receptacle to the center line of each decal shall be 12”.
- One 3” decal shall be provided on each short side and one 5” decal shall be provided on each long side of the Slim Jim for a total of 4 decals per bin.
- Decals shall be custom heat stamped white graphics applied by the manufacturer.



Cafés / Cafeterias / Pantries (if required)

▪ **Red Medical Waste / Hazardous Receptacles**

- Decals shall be 4” in diameter.
- Decals shall be centered horizontally on both the lid and front of each bin.
- Lid decal shall be centered vertically between the outer edge of the lid and top edge of the manufacturer logo.
- Front decal shall be centered vertically between the bottom edge of the lid and the top edge of the step recess.
- Decals shall be custom heat stamped white graphics applied by the manufacturer.



■ **Cafés / Cafeterias** (Wall Mounted)

- Decals or signs shall be custom size to fit the architecture. For example, in some cases, the decals will go on a tile wall. In those cases the decal shall be sized to match the height and width of the tiles.
- Each decal shall be centered on and located directly above its respective opening.
- Each decal shall be second surface screen printed, back painted on clear acrylic, and no paint on returns.
- Tray signs should also be provided and be first surface etched and paint-filled on 1/4” thick horizontal-brushed aluminum.

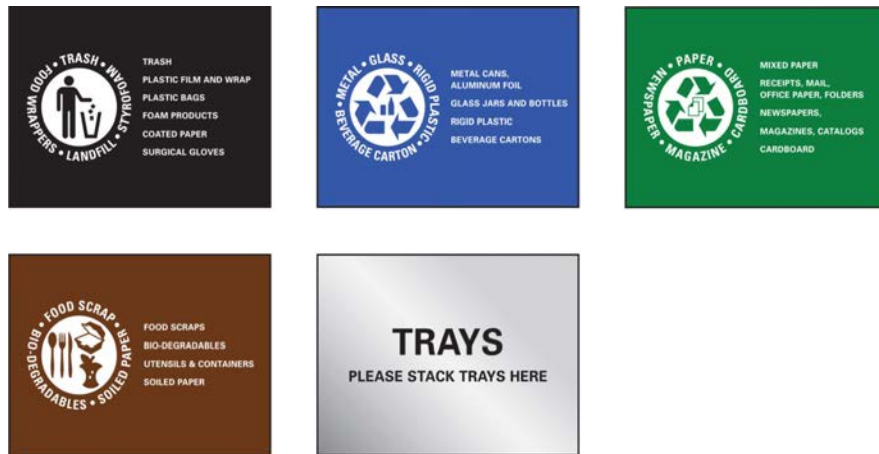

5. *Locations for Trash and Recycling Receptacles* - To assist the A/E Team, below is a summary of approved locations for each bin type included in the Trash and Recycling Receptacle Specifications provided:

Front-of-House Areas	Receptacle Specification																		
	R1a–R1b	R1c–R1d	R1e	R1f	R1g	R1h	R2a	R2b–R2d	R2e	R3a	R3b	R3c	R3d	R3e	R4a–R4i	R6a	R6b–R6d	[Reserved]	[Reserved]
Entry Vestibule	Not Permitted																		
Building Lobbies	✓	✓					✓	✓											
Public Elevator Lobbies	Not Permitted																		
Reception / Waiting Areas	✓	✓		✓				✓		✓									
Family Lounge	✓	✓		✓				✓		✓									
Seminar Rooms/Lecture Halls/Auditoriums (outside of space)	✓						✓	✓											
Multipurpose Rooms	✓	✓		✓			✓	✓			✓								
Training Rooms (outside of space)	✓		✓				✓	✓											
Miscellaneous Public Areas	✓	✓			✓			✓											
Conference Rooms (12+ occupants)	✓	✓		✓				✓			✓								
Discussion / Small Conference Rooms (<12 occupants)	Not Required																		
Open Work Areas	✓		✓					✓				✓							
Private Office / Workstation	Paper by request only																		
Cafés and Cafeterias									✓					✓					
Pantries			✓						✓		✓		✓						
Staff / Student Lounges, Break Rooms & Study Spaces	✓	✓	✓	✓			✓	✓	✓		✓								
Lactation Rooms (trash only)										✓									
Public Corridors (if necessary)						✓													
Toilet Rooms	Refer to the Toilet Accessories subsection of these Design Guidelines																		
Millwork/Casework (rigid liner)															✓				
Exterior Building Entries (trash only, if necessary)																✓			
Courtyards / Terraces (if necessary)																	✓		

Back-of-House Areas	Receptacle Specification																		
	R5a (Black)	R5a (Blue)	R5a (Green)	R5b (Black)	R5b (Blue)	R5b (Green)	R5b (Brown)*	R5c (Black)	R5c (Blue)	R5c (Green)	R5c (Brown)*	R5d	R5e (Tan)	R5f (Blue)	R5g (RMW)	R5h (RMW)	Sharps	Shred-X	[Reserved]
Copy / Printer Rooms (paper only)			✓															✓	
Staff Lockers	✓	✓	✓																
Clinical Areas													✓	✓	✓		✓		
Research Areas	✓	✓	✓												✓	✓	✓		
Food Prep (below counter)				✓	✓	✓	✓	✓	✓	✓	✓								
Service Corridors	✓	✓	✓																
Service Elevator Lobbies	✓	✓	✓																
As Required by Code												✓							
Notes:																			
1. Items denoted with an * may be used only where compost services are provided.																			
2. Coordinate trash and recycling receptacle specifications and locations for Back-of-House areas with the Design Studio, appropriate maintenance department (i.e. Building Services, Environmental Services, etc.) and end-user during the Design Development phase.																			

6. *Trash and Recycling Receptacle Specifications*

The Architect and Interior Designer should use the information below as a guide for specifying trash and recycling receptacles on NYU Langone capital projects. This information does not relieve the Architect or Interior Designer of specifying products that are appropriate and code compliant for specific spaces. It is the Architect’s responsibility to select items that are code compliant and appropriate for the capital project based on the type of space and end-user needs. The Architect and Interior Designer shall consider specifying existing building-specific standards provided they are in line with these Design Guidelines. Architects shall coordinate with the RED+F Project Manager, Facilities Operations, Environmental Services / Building Services and the Design Studio to finalize product selections.

The product specifications included in this subsection are organized by type as follows:

- R1. Front-of-House Receptacles
- R2. Custom Freestanding Casework Receptacles
- R3. Custom Built-in Millwork
- R4. Internal Rigid Liners
- R5. Back-of-House Receptacles
- R6. Outdoor Receptacles



R1. FRONT-OF-HOUSE RECEPTACLES						
Image	Description	Manuf.	Model/Finish	Clinical	Non-Clinical	
R1a		Trash / Recycling Center	MaxR	Custom / Stainless Steel or Plastic Laminate	*	*
		<p>Location: <i>Refer to the Locations for Trash and Recycling Receptacles Spreadsheet</i></p> <p>Remarks: Specify the following configuration: 18 gal trash 18 gal metal-glass-plastic 18 gal paper Model – Customized Royal Triple Top Load Openings – 8” x 12” trash opening, 6” dia. metal-glass-plastic opening, and 3” x 12” paper slot Rigid Liners – by manufacturer Dimensions – 23-3/4”D x 39-1/4”W x 30-7/8”H</p>				
R1b		Trash / Recycling Center	MaxR	Custom / Stainless Steel or Plastic Laminate	*	*
		<p>Location: <i>Refer to the Locations for Trash and Recycling Receptacles Spreadsheet</i></p> <p>Remarks: Specify the following configuration: 22 gal trash 22 gal metal-glass-plastic 22 gal paper Model – Customized Royal Triple Top Load Openings – 8” x 12” trash opening, 6” dia. metal-glass-plastic opening, and 3” x 12” paper slot Rigid Liners – by manufacturer Dimensions – 23-5/16”D x 37-5/8”W x 34-15/16”H</p>				
R1c		Trash / Recycling Center	Nucraft	Recycling Center / Varies	*	*
		<p>Location: <i>Refer to the Locations for Trash and Recycling Receptacles Spreadsheet</i></p> <p>Remarks: Specify the following configuration: 10.25 gal trash 10.25 gal metal-glass-plastic 10.25 gal paper Model – RYC-3628-3VN (36” x 28” 3-station unit); Provide with brushed aluminum top and wood to match adjacent finishes. Rigid Liners – by manufacturer Openings – 4” x 9” trash opening, 6” dia. bottles/cans opening, and 2” x 9” paper slot Dimensions – 18”D x 36”W x 28”H</p>				





Image	Description	Manuf.	Model/Finish	Clinical	Non-Clinical
 <p>R1d</p>	Trash / Recycling Center	Magnuson Group	PIC / Silver	*	*
	<p>Location: Refer to the Locations for Trash and Recycling Receptacles Spreadsheet</p> <p>Remarks: Specify the following configuration: Clinical (w/ rigid liners): 9.3 gal trash 9.3 gal metal-glass-plastic 9.3 gal paper Non-Clinical (w/o rigid liners): 16 gal trash 16 gal metal-glass-plastic 16 gal paper Model – PIC 3x60L-NYU (w/ standard openings, and single drop-in lid painted to match the body) Rigid Liners – by manufacturer (spec w/ rigid internal liners for clinical locations only) Openings – Large square trash opening (left), 6” round metal-glass-plastic opening (middle) and standard paper slot (right) Dimensions – 11-7/8”D x 35-5/16”W x 26-15/16”H</p>				
Image	Description	Manuf.	Model/Finish	Clinical	Non-Clinical
 <p>R1e</p>	Trash / Recycling Center	Steelcase	Victor 2 / Varies	*	*
	<p>Location: Refer to the Locations for Trash and Recycling Receptacles Spreadsheet</p> <p>Remarks: Specify the following configuration: 12 gal trash 12 gal metal-glass-plastic 12 gal paper Model – ARM183636 (Mobile 3-Opening); Acrylic inserts shall be adhered to face of receptacle. Access to liners via doors in back. Receptacles to be provided with casters. Rigid Liners – by manufacturer Openings – Provide waste, returnables and paper acrylic inserts less mfr. decals. Dimensions – 18”D x 36”W x 36”H Note – In open work areas and pantries, permitted <u>only</u> when built-ins are not possible.</p>				
Image	Description	Manuf.	Model/Finish	Clinical	Non-Clinical
 <p>R1f</p>	Trash / Recycling Credenza	Nucraft	Flow (NYULH Custom) / Varies	*	*
	<p>Location: Refer to the Locations for Trash and Recycling Receptacles Spreadsheet</p> <p>Remarks: Available as follows: 19 gal trash 19 gal metal-glass-plastic 19 gal paper Model – Top surface to be either solid surface, quartz/resin or stone. Wood / laminate finish to match conf. room table. Rigid Liners – R4f Openings – 12” x 6” openings in face of cabinet Dimensions – 20”D x 34”H (width varies)</p>				

Image		Description	Manuf.	Model/Finish	Clinical	Non-Clinical
R1g		Trash / Recycling Receptacle	Safco	9941SS / Brushed Alum.	*	*
		<p>Location: <i>Miscellaneous Public Areas</i></p> <p>Remarks: Specify the following configuration: 20 gal trash 10 gal metal-glass-plastic 10 gal paper Model – 9941SS Rigid Liners – by manufacturer Openings – one large trash opening; two smaller openings for bottles/cans and paper Dimensions – 20” dia. x 34”H (Approval by RED+F Design Studio required.)</p>				
Image		Description	Manuf.	Model/Finish	Clinical	Non-Clinical
R1h		Trash/ Recycling Center	Magnuson Group	Valuta / Anodized Silver	*	*
		<p>Location: <i>Public Corridors (if necessary)</i></p> <p>Remarks: Specify the following configuration: 20 gal trash 20 gal metal-glass-plastic 20 gal paper Model – 3 x VA1809L-NYU (smooth top) Provide with (2) sets of ganging magnets #GNG-MAG-2 Provide with (2) sets of ganging plates # GNG-PLT-2 Rigid Liners – by manufacturer Openings –4-1/4” x 13-3/16” trash opening, 4-1/4” dia. metal-glass-plastic opening, and 2” x 12” paper slot w/ custom rounded ends Dimensions – 9”D x 54”W x 33-3/4”H (Approval by RED+F Design Studio required.)</p>				

R2. CUSTOM FREESTANDING CASEWORK RECEPTACLES						
<p>For custom freestanding casework receptacles:</p> <ol style="list-style-type: none"> 1. Provide casework with customized cabinets sized to fit a standard plastic rigid liner as shown in section R4. Internal Rigid Liners. 2. Ensure that the cabinet cavity does not allow movement of the rigid liner as that often causes waste to be dropped between the opening and the bin and presents a cleanliness issue. 3. Draw to scale the specified internal rigid liners on the shop drawings. 4. Provide openings trimmed in stainless steel at plastic laminate locations. 5. Ensure that provided openings do not allow view of the rigid liners. 6. Top may be stainless steel or solid surface. Body may be stainless steel or HPL. Doors shall have continuous hinges. Push touch latch is preferred. If pulls are necessary RED+F Design Studio approval is required. Base may be 1-1/2" black HPL or stainless steel and shall have concealed levelers. <p>List of NYULH-approved furniture vendors is shown below. Other vendors may be considered.</p> <ol style="list-style-type: none"> 1. Hamilton 2. Beachley 3. Fabricate 4. MadGirl 5. Lacasse 						
Image	Description	Manuf.	Model/Finish	Clinical	Non-Clinical	
R2a	Trash / Recycling Center	Furniture Vendor	Custom / Varies	*	*	
	<p>Location: <u>Refer to the Locations for Trash and Recycling Receptacles Spreadsheet</u></p> <p>Remarks: Specify the following configuration: 32 gal trash 23 gal metal-glass-plastic 23 gal paper Openings – 12" x 12" trash opening, 6" dia. metal-glass-plastic opening, and 3" x 12" paper slot Rigid Liners – R4i for trash, R4e for metal-glass-plastic and paper Dimensions – 25"D x 56"W x 34"H</p>					
Image	Description	Manuf.	Model/Finish	Clinical	Non-Clinical	
R2b	Trash / Recycling Center	Furniture Vendor	Custom / Varies	*	*	
	<p>Location: <u>Refer to the Locations for Trash and Recycling Receptacles Spreadsheet</u></p> <p>Remarks: Specify the following configuration: 16/23 gal trash 16/23 gal metal-glass-plastic 16/23 gal paper Openings – 8" x 12" trash opening, 6" dia. metal-glass-plastic opening, and 3" x 12" paper slot Rigid Liners – R4d for 16 gal version R4e for 23 gal version Dimensions – 25"D x 38-1/2"W x 30"H (16 gal version) 25"D x 38-1/2"W x 34"H (23 gal version)</p>					

Image		Description	Manuf.	Model/Finish	Clinical	Non-Clinical
R2c		Trash / Recycling Center	Furniture Vendor	Custom / Varies	*	*
		<p>Location: Refer to the Locations for Trash and Recycling Receptacles Spreadsheet</p> <p>Remarks: Specify the following configuration: 19/23 gal trash 19/23 gal metal-glass-plastic 19/23 gal paper Openings – 8” x 12” trash opening, 6” dia. metal-glass-plastic opening, and 3” x 12” paper slot Rigid Liners – R4f for 19 gal version R4g for 23 gal version Dimensions – 20”D x 54”W x 30”H (19 gal version) / 36”H (23 gal version)</p>				
R2d		Trash / Recycling Center	Furniture Vendor	Custom / Varies	*	*
		<p>Location: Refer to the Locations for Trash and Recycling Receptacles Spreadsheet</p> <p>Remarks: Specify the following configuration: 23 gal trash 23 gal metal-glass-plastic 23 gal paper Openings – 8” x 12” trash opening, 6” dia. metal-glass-plastic opening, and 3” x 12” paper slot Rigid Liners – R4e Dimensions – 14-1/2”D x 72”W x 34”H</p>				
R2e		Trash / Recycling Center	Furniture Vendor	Custom / Varies	*	*
		<p>Location: Refer to the Locations for Trash and Recycling Receptacles Spreadsheet</p> <p>Remarks: Specify the following configuration: 32 gal trash 16 gal metal-glass-plastic 16 gal paper Rigid Liners – R4i trash; R4d metal-glass-plastic and paper Openings – 16” x 8” trash opening, 8” dia. metal-glass-plastic opening, and 12” x 3” paper slot Dimensions – 25”D x 60”W x 42”H Note – Permitted <u>only</u> when built-ins are not possible.</p>				



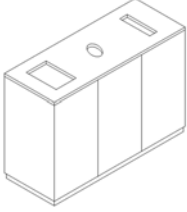
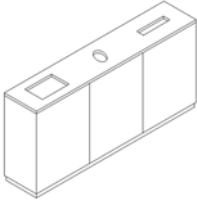
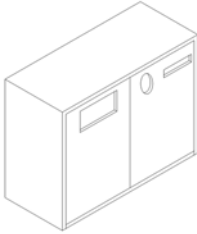





R3. CUSTOM BUILT-IN MILLWORK						
<p>For trash and recycling built into custom millwork:</p> <ol style="list-style-type: none"> 1. Provide millwork that matches / coordinates with adjacent finishes. 2. Provide millwork with customized cabinets or drawers sized to fit a standard plastic rigid liner as shown in section R4. Internal Rigid Liners. 3. Cabinet doors or drawer fronts with integral toekicks where the rigid liner rests on the floor are preferred. 4. Ensure that the cabinet or drawer cavity does not allow movement of the rigid liner as that often causes waste to be dropped between the opening and the bin and presents a cleanliness issue. 5. Draw to scale the specified internal rigid liners on both the millwork details and the shop drawings. 6. Provide openings trimmed in stainless steel at plastic laminate locations. 7. Ensure that provided openings do not allow view of the rigid liners. 						
Image	Description	Manuf.	Model/Finish	Clinical	Non-Clinical	
R3a		Built-in Trash / Recycling Center	Custom	Custom / Varies	*	*
<p>Location: <u>Refer to the Locations for Trash and Recycling Receptacles Spreadsheet</u></p> <p>Remarks: Provide the following configuration: 10/13/19 gal trash 10/13/19 gal metal-glass-plastic 10/13/19 gal paper Model – Custom millwork w/ 34” high counter Rigid Liners – Use R4b (13 gal) or R4f (19-gal) when integral toekick is provided. Use R4a (10 gal) when standard toekick is provided. Openings – 12” x 6” openings Dimensions – vary</p>						
Image	Description	Manuf.	Model/Finish	Clinical	Non-Clinical	
R3b		Built-in Trash / Recycling Center	Custom	Custom / Varies	*	*
<p>Location: <u>Refer to the Locations for Trash and Recycling Receptacles Spreadsheet</u></p> <p>Remarks: Provide the following configuration: 13/19/28 gal trash 13/19/28 gal metal-glass-plastic 13/19/28 gal paper 13/19/28 compost (where provided) Model – Custom millwork w/ 34” high counter Rigid Liners – Use R4b (13 gal), R4f (19-gal) or R4h (28 gal) when integral toekick is provided. Openings – 12” x 8” openings Dimensions – vary</p>						

Image	Description	Manuf.	Model/Finish	Clinical	Non-Clinical
<p>R3c</p> 	<p>Trash / Recycling Center</p>	<p>Varies</p>	<p>Custom / Varies</p>	<p>*</p>	<p>*</p>
<p>Location: <u>Open Work Areas @ File/Locker Bar</u> Remarks: Available as follows: 16/23/32 gal trash 16/23/32 gal metal-glass-plastic 16/23/32 gal paper Model – Custom millwork w/ 42” high counter Rigid Liners – Use R4e (23-gal), R4g (23 gal) or R4i (32 gal) when integral toekick is provided. Use R4d (16 gal) or R4c (23 gal) when standard toekick is provided. Openings – Single and double-sided access as required; 12” x 8” trash opening, 8” dia. metal-glass-plastic opening, and 12” x 3” paper slot Dimensions – Vary</p>					
Image	Description	Manuf.	Model/Finish	Clinical	Non-Clinical
<p>R3d</p> 	<p>Built-in Trash / Recycling Center</p>	<p>Varies</p>	<p>Custom / Varies</p>	<p>*</p>	<p>*</p>
<p>Location: <u>Pantries</u> Remarks: Provide the following configuration: 16/23/32 gal trash 16/23 gal metal-glass-plastic 16/23 gal paper 16/23 gal compost (if provided) Model – Custom millwork w/ 42” high counter Rigid Liners – Use R4e (23-gal), R4g (23 gal) or R4i (32 gal) when integral toekick is provided. Use R4d (16 gal) or R4c (23 gal) when standard toekick is provided. Openings – 12” x 8” openings Dimensions – vary</p>					
Image	Description	Manuf.	Model/Finish	Clinical	Non-Clinical
<p>R3e</p>  <p>**Preferred**</p>	<p>Built-in Trash / Recycling Center</p>	<p>Varies</p>	<p>Custom / Varies</p>	<p>*</p>	<p>*</p>
<p>Location: <u>Café / Cafeteria</u> Remarks: Provide the following configuration: 20 gal trash 20 gal metal-glass-plastic 20 gal paper 20 gal compost (only where compost collection is available) Model – Custom millwork w/ 34” high counter Rigid Liners – Use R4e (23 gal), R4g (23 gal) or R4i (32 gal) when integral toekick is provided. Use R4d (16 gal), R4f (19 gal) or R4i (32 gal) when standard toekick is provided. Openings – 10” x 10” trash opening, 10” dia. metal-glass-plastic opening, 10” x 10” compost opening and 10” dia. paper opening. Dimensions – vary</p>					

R4. INTERNAL RIGID LINERS						
Image	Description	Manuf.	Model/Finish	Clinical	Non-Clinical	
R4a		Receptacle	Rubbermaid	Large Wastebasket	*	*
		Location: <u>Millwork/Casework Internal Liner</u> Remarks: Specify as follows: 10.25 gal Model – #FG295700BLA Dimensions – 11”D x 15-1/4”W x 19-7/8”H				
Image	Description	Manuf.	Model/Finish	Clinical	Non-Clinical	
R4b		Utility Receptacles	Rubbermaid	Slim Jim Under Counter	*	*
		Location: <u>Millwork/Casework Internal Liner</u> Remarks: Specify as follows: 13 gal Model – #2026695 Gray Dimensions – 22.23”D x 11.17”W x 22.5”H (at front) x 26.09”H (at rear)				
Image	Description	Manuf.	Model/Finish	Clinical	Non-Clinical	
R4c		Utility Receptacles	Rubbermaid	Slim Jim Under Counter	*	*
		Location: <u>Millwork/Casework Internal Liner</u> Remarks: Specify as follows: 23 gal Model – #2026721 Gray Dimensions – 22.06”D x 15.80”W x 26”H (at front) x 30”H (at rear)				
Image	Description	Manuf.	Model/Finish	Clinical	Non-Clinical	
R4d		Utility Receptacles	Rubbermaid	Slim Jim Container	*	*
		Location: <u>Millwork/Casework Internal Liner</u> Remarks: Specify as follows: 16 gal Model – #1971258 Gray Dimensions – 22”D x 11”W x 25”H				
Image	Description	Manuf.	Model/Finish	Clinical	Non-Clinical	
R4e		Utility Receptacles	Rubbermaid	Slim Jim Container	*	*
		Location: <u>Millwork/Casework Internal Liner</u> Remarks: Specify as follows: 23 gal Model – #FG354060 GRAY Dimensions – 22”D x 11”W x 30”H				

Image	Description	Manuf.	Model/Finish	Clinical	Non-Clinical
 <p>R4f</p>	Utility Receptacles	Lavex	Janitorial Square	*	*
	<p>Location: <u>Millwork/Casework Internal Liner</u> Remarks: Specify as follows: 19 gal Model – #475SQ19GY Dimensions – 15-13/16”D x 15-7/16”W x 21-1/4”H</p>				
Image	Description	Manuf.	Model/Finish	Clinical	Non-Clinical
 <p>R4g</p>	Utility Receptacles	Rubbermaid	Untouchable Square	*	*
	<p>Location: <u>Millwork/Casework Internal Liner</u> Remarks: Specify as follows: 23 gal Model – #FG356988 GRAY Dimensions – 15.5”D x 16.5”W x 32.9”H</p>				
Image	Description	Manuf.	Model/Finish	Clinical	Non-Clinical
 <p>R4h</p>	Utility Receptacles	Rubbermaid	Brute Square	*	*
	<p>Location: <u>Millwork/Casework Internal Liner</u> Remarks: Specify as follows: 28 gal Model – #FG352600 GRAY Dimensions – 21.5”D x 25.13”W x 22.5”H</p>				
Image	Description	Manuf.	Model/Finish	Clinical	Non-Clinical
 <p>R4i</p>	Utility Receptacles	Rubbermaid	Brute Round	*	*
	<p>Location: <u>Millwork/Casework Internal Liner</u> Remarks: Specify as follows: 32 gal Model – #FG262000YEL Dimensions – 21.92”D x 25.98”W x 27.25”H</p>				





R5. BACK-OF-HOUSE RECEPTACLES						
	Image	Description	Manuf.	Model/Finish	Clinical	Non-Clinical
R5a		Utility Receptacles	Rubbermaid	Slim Jim Container	*	*
		<p>Location: <u>Refer to the Locations for Trash and Recycling Receptacles Spreadsheet</u></p> <p>Remarks: Specify as follows: 23 gal Model – Container: #FG354060 BLA (trash) Lid: #FG267360 BLA (trash) Container: #FG354007 BLUE (metal-glass-plastic) Lid: #FG269288 BLUE (metal-glass-plastic) Container: #FG354007 GRN (paper) Lid: #FG270388 GRN (paper) Decals – Mfr. to provide custom NYU Langone approved decals. Refer to Item 5. Decal Requirements within this subsection for add'l labeling information. Dimensions – 22”D x 11”W x 30”H (container only)</p>				
	Image	Description	Manuf.	Model/Finish	Clinical	Non-Clinical
R5b		Utility Receptacles	Rubbermaid	Slim Jim Under Counter	*	*
		<p>Location: <u>Food Prep (exposed below counter)</u></p> <p>Remarks: Specify as follows: 13 gal Model – #2026696 Black (trash) #2026699 Blue (metal-glass-plastic) #2026700 Green (paper) #2026697 Brown (compost*) * Only where compost collection is available. Dimensions – 22.23”D x 11.17”W x 22.5”H (at front) x 26.09”H (at rear)</p>				

Image	Description	Manuf.	Model/Finish	Clinical	Non-Clinical
	Utility Receptacles	Rubbermaid	Slim Jim Under Counter	*	*
	<p>Location: <u>Food Prep (exposed below counter)</u></p> <p>Remarks: Specify as follows: 23 gal Model – #2026722 Black (trash) #2026725 Blue (metal-glass-plastic) #2026726 Green (paper) #2026723 Brown (compost*) * Only where compost collection is available. Dimensions – 22.06”D x 15.80”W x 26”H (at front) x 30”H (at rear)</p>				
Image	Description	Manuf.	Model/Finish	Clinical	Non-Clinical
	Receptacle	Rubbermaid	Fire-Resistant Waste	*	*
	<p>Location: <u>Locate as required by code</u></p> <p>Remarks: Specify as follows: 10 gal Model – #FG254400BEIG Dimensions – 11-1/4”D x 15”W x 20”H</p>				
Image	Description	Manuf.	Model/Finish	Clinical	Non-Clinical
	Clinical Receptacles	Rubbermaid	Streamline Resin Step-on	*	
	<p>Location: <u>Clinical Areas</u></p> <p>Remarks: Specify as follows: 18 gal 24 gal Model – #1883460 (18 gal) #1883552 (24 gal) Dimensions – 12”D x 20”W x 32”H (18 gal) 13.97”D x 23.38”W x 32.70”H (24 gal)</p>				
Image	Description	Manuf.	Model/Finish	Clinical	Non-Clinical
	Utility Receptacles	Rubbermaid	Slim Jim Container	*	*
	<p>Location: <u>Clinical Areas</u></p> <p>Remarks: Specify as follows: 23 gal Model – Container: #FG354007 BLUE (metal-glass-plastic) Lid: #FG267360 BLUE (metal-glass-plastic) Decals – Mfr. to provide custom NYU Langone approved decals. Refer to Item 5. Decal Requirements within this subsection for add'l labeling information. Dimensions – 22”D x 11”W x 30”H (container only)</p>				

Image	Description	Manuf.	Model/Finish	Clinical	Non-Clinical
	RMW Receptacles	Rubbermaid	Streamline Resin Step-on	*	*
	Location: <i>Research / Clinical Areas</i> Remarks: Specify as follows: 8 gal Model – #1883564 RED (hazardous / medical waste) Decals – Mfr. to provide custom NYU Langone approved decals. Refer to Item 5. Decal Requirements within this subsection for add'l labeling information. Dimensions – 11.38”D x 17.67”W x 21.3”H				
Image	Description	Manuf.	Model/Finish	Clinical	Non-Clinical
	RMW Receptacles	Rubbermaid	Streamline Resin Step-on		*
	Location: <i>Research Areas</i> Remarks: Specify as follows: 24 gal Model – #1883570 RED (hazardous waste) Decals – Mfr. to provide custom NYU Langone approved decals. Refer to Item 5. Decal Requirements within this subsection for add'l labeling information. Dimensions – 13.97”D x 23.38”W x 32.70”H				



R6. OUTDOOR RECEPTACLES					
Image	Description	Manuf.	Model/Finish	Clinical	Non-Clinical
	Covered Outdoor Trash Receptacle	Forms+ Surfaces	Universal / Seastone Stainless Steel	*	*
	Location: <i>Exterior Building Entries</i> Remarks: Specify as follows: 30 gal trash Model – SLUNN-30SSS Body Finish – Seastone Stainless Steel Body Pattern – No Pattern Base Material – Polyethylene, Slate Installation Option – Freestanding Lid Tether – None Number of Liners – One full liner Liner Options – Provide w/ bag straps and drain holes Rigid Liners – by manufacturer Opening – Standard Dimensions – 21.5” dia. x 37.5” H				
Image	Description	Manuf.	Model/Finish	Clinical	Non-Clinical
 <p>**Preferred**</p>	Covered Outdoor Trash / Recycling Receptacle	Mmcité	Crystal / Stainless Steel	*	*
	Location: <i>Courtyards / Terraces</i> Remarks: Specify as follows: 14.5 gal trash 8.5 gal metal-glass-plastic 8.5 gal paper Model – CS350n; no ashtray; no opening covers Rigid Liners – by manufacturer Openings – Provide with standard openings. Dimensions – 10.2”D x 37.2”W x 38.8”H				

	Image	Description	Manuf.	Model/Finish	Clinical	Non-Clinical
R6c		<p>Covered Outdoor Trash / Recycling Receptacle</p>	Forms+Surfaces	Apex / Sandstone Stainless Steel		*
<p>Location: <i>Courtyards / Terraces</i></p> <p>Remarks: Specify the following configurations, one of each is required to form a triple stream set:</p> <p>36 gal single-stream trash Model – SLAPX-136S Finish – Sandstone Stainless Steel Graphic Message – None Rain Cover – Yes Latch Options – Std. Lift Latch Liner Options – Provide w/ bag straps and drain holes Mounting – Freestanding w/ Levelers Dimensions – 15”D x 32”W x 40.5”H (w/ Rain Cover)</p> <p>36 gal split-stream (18 gal metal-glass-plastic 18 gal paper) Model – SLAPX-36S Finish – Sandstone Stainless Steel Graphic Message – None Rain Cover – Yes Latch Options – Std. Lift Latch Liner Options – Provide w/ bag straps and drain holes Mounting – Freestanding w/ Levelers Dimensions – 15”D x 32”W x 40.5”H (w/ Rain Cover) Rigid Liners – by manufacturer Openings – Standard Note – Receptacles are to be placed side-by-side 6” apart.</p>						
	Image	Description	Manuf.	Model/Finish	Clinical	Non-Clinical
R6d		<p>Covered Outdoor Trash / Recycling Receptacle</p>	Forms+Surfaces	Apex / Jatoba Wood + Sandstone Stainless Steel		*
<p>Location: <i>Courtyards / Terraces</i></p> <p>Remarks: Specify the following configurations, one of each is required to form a triple stream set:</p> <p>36 gal single-stream trash Model – SLAPX-136J Finish – Jatoba Wood + Sandstone Stainless Steel Graphic Message – None Rain Cover – Yes Latch Options – Std. Lift Latch Liner Options – Provide w/ bag straps and drain holes Mounting – Freestanding w/ Levelers Dimensions – 15”D x 32”W x 40.5”H (w/ Rain Cover)</p> <p>36 gal split-stream (18 gal metal-glass-plastic 18 gal paper) Model – SLAPX-36J Finish – Sandstone Stainless Steel Graphic Message – None Rain Cover – Yes Latch Options – Std. Lift Latch Liner Options – Provide w/ bag straps and drain holes Mounting – Freestanding w/ Levelers Dimensions – 15”D x 32”W x 40.5”H (w/ Rain Cover) Rigid Liners – by manufacturer Openings – Standard Note – Receptacles are to be placed side-by-side 6” apart.</p>						

DOOR HARDWARE

Instructions to Architects for preparing a hardware specification.

- A. The Architect and Interior Designer should use this section as a guide for specifying door hardware on NYU Langone capital projects. This information does not relieve the Architect or Interior Designer of specifying products that are appropriate and code compliant for specific spaces. The Architect and Interior Designer may suggest other products if they believe those products meet the design intent of the project and this section of the Design Guidelines.
- B. The architect shall develop a hardware schedule that is code compliant to: NYC Building Code, CMS, Joint Commission, NFPA and all other applicable codes.
- C. These hardware guidelines are for the main campus at NYU Langone Health. The architect shall follow these guidelines in conjunction with any applicable building codes. In addition:
 - for the NYU Langone – Long Island campus, the architect shall follow these guidelines in conjunction with their standard hardware.
 - for NYU Langone Hospital – Brooklyn campuses, the architect shall follow these guidelines in conjunction with their standard hardware. Yale hardware sets shall be used in lieu of Sergeant.
 - for Off-site locations, the architect shall follow these guidelines in conjunction with the building landlord’s hardware requirements.
- D. The Architect shall follow the Fire-Rated Hollow Metal Door Standards by RED+F’s Facilities department. All fire-rated doors and frames shall be fully welded.
- E. It shall be the Architect’s responsibility to coordinate all work with NYU Langone Security, Fire Alarm, and Infant Abduction System (if applicable) Vendors and associated NYU Langone personnel. Where power and control is required to electrical hardware that is not being furnished by the Security Vendor, the Architect and/or the Electrical Engineer shall provide wiring diagrams for all hardware specified in the Finish Hardware portion of this Specification. It shall also be the Architect’s responsibility to provide a sequence of operations for all automatic doors for all scenarios (i.e.: daytime, nighttime, upon activation of fire alarm, etc.).
- F. Where automatic operators are specified, it shall be the Architect’s responsibility to coordinate all power and control to the automatic operators and accessories (proximity readers, paddles, intercom systems, etc.), including logic for tie-in to fire alarm and infant abduction systems. The Architect and/or the Electrical Engineer shall provide wiring diagrams that show all wiring and power requirements to the automatic operator and accessories. The Architect shall include in the specifications that the automatic operator shall be furnished and installed by an authorized Stanley distributor. The same automatic operator provider and installer shall also furnish and install all electronic locking hardware, as may be required, for all automatic operated doors.

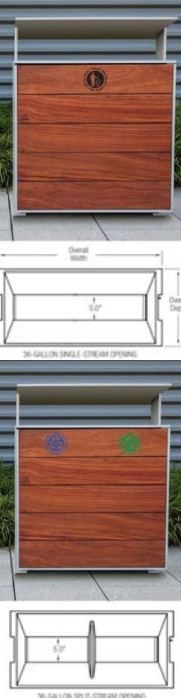
- G. The Architect shall include in the specification a paragraph stating that the GC is responsible for setting up a pre-installation meeting between the hardware installer, the automatic door vendor and the security vendor to coordinate installation of all trades.
- H. The Architect shall include in the specification the submission of a Quality Control Plan (QCP) for fire-rated doors, frames and hardware to RED+F Commissioning within 30 days of contract award. The QCP shall require that:
- NYU Langone engage an independent on-site commissioning agent dedicated to the inspection of fire-rated doors, frames and hardware.
 - The inspection will be based on the requirements set forth in the NYC Building Code and NFPA 80 – Standards for Fire Doors & Other Opening Protectives. The door, frame and hardware installation shall comply with the requirements set forth in NFPA 80 for all clearance and install requirements and NFPA 101 for inspection of door openings.
 - The agent shall use an electronic inventory tracking system (EITS) made accessible to RED+F staff and the A/E Team to track inventory and installation/inspection status.
 - The agent shall inspect each fire-rated door, frame and hardware installation for compliance and acceptance and prepare a report at the intervals described below:
 - Stage 1: Inspect the frame installation upon completion of the preliminary bracing of pressed steel frames prior to wall installation.
 - Stage 2: Re-inspect the frame installation upon completion of the wall construction by the masonry and drywall trades.
 - Stage 3: Re-inspect the assembly upon completion of the hollow metal doors and architectural hardware.
 - Stage 4: Re-inspect the assembly upon completion of electrical work including security and fire alarm installation.
 - The Contractor shall not proceed to the next stage until all deficiencies have been corrected, re-inspected and approved.

Contents**1.1 Hanging Devices**

- A. Full Mortise Hinges
- B. Swing Clear Hinges
- C. Lead Lined Pivots
- D. Center Hung Pivots
- E. Continuous Hinges

1.2 Locking and Latching Devices

- A. Mortise Locks and Latches
- B. Cylinders and Keying
- C. Cylindrical Locks at Existing Doors
- D. Combination Locks
- E. Hospital Push Pull Latches
- F. Exit Devices
- G. Electric Locks

1.3 Door Closing Devices

- A. Surface Mounted Door Closers
- B. Floor Closers

1.4 Door Stops

- A. Wall and Floor Stops
- B. Overhead Stops

1.5 Protection Plates

- A. Kick Plates
- B. Mop Plates
- C. Armor Plates

1.6 Flush Bolts

- A. Automatic Flush Bolts
- B. Manual Flush Bolts

1.7 Automatic Operators**1.8 Card Access Doors****2.1 Typical Hardware Sets (by Room Type)****2.2 Typical Electrical Hardware Sets (by Door Type)**

1.1 Hanging Devices

A. Full Mortise Hinges:

1. Unless otherwise noted, all doors shall be hung on full mortise five knuckle ball bearing type, template hinges, with non-rising loose pins. All out-swing doors shall be furnished with non-removable pins (NRP).
 - a. All hinges for 1-3/4" thick doors shall be 4-1/2" wide in the open position. For other thickness doors, hinges shall be of a width to permit unobstructed swing of the doors.
 - b. Size and weight of hinges shall conform to the following:
 - Up to 36" ----- 4-1/2" heavy weight
 - Over 36" to 46" ----- 5" heavy weight
 - Over 46" ----- Roton 780 series
 - c. Quantity of hinges shall be provided to conform to the following:
 - Doors up to 60" in height----- 2 hinges
 - Doors 60" to 90" in height ----- 3 hinges
 - Doors 90" and over ----- 1 hinge every 30" in height
 - d. Approved Manufacturers: No other manufacturer’s products are approved.
 - PBB: Standard Duty BB81/51 series & Heavy Duty 4B81/51 series.
 - Stanley: Standard Duty FBB179/191 series & Heavy Duty FBB168/199 series.
 - McKinney: Standard Duty TA2714/2713 series & Heavy Duty T4A3786/ T4A3386.

B. Swing Clear Hinges:

1. Unless otherwise noted, all patient room doors and doors that will receive heavy cart traffic shall be furnished with heavy weight full mortise five knuckle ball bearing type, template swing clear hinges.
 - a. Size and weight of hinges shall conform to the following:
 - All Doors----- 5" heavy weight
 - b. Quantity of hinges shall be provided to conform to the following:
 - Doors up to 60" in heights ----- 2 hinges
 - Doors 60" to 90" in height ----- 3 hinges
 - Doors 90" and over ----- 1 hinge every 30" in height
 - c. Approved Manufacturers: No other manufacturer’s products are approved.
 - PBB: Heavy Duty SC4B81-5”
 - Stanley: Heavy Duty FBB268-5”
 - McKinney: Heavy Duty T4B3795-5”

C. Lead Lined Pivots:

1. Unless otherwise noted, all lead lined doors shall be furnished with lead lined top and bottom pivots including lead lined intermediate pivots.
 - a. Quantity of intermediate pivots shall be provided to conform to the following:
 - Doors up to 84" in height----- 1 intermediate pivot
 - Doors 84" and over ----- 1 intermediate pivot every 30" in height
 - b. Approved Manufacturers: NO SUBSTITUTIONS.
 - Rixson: L147 x ML19 x US26D.

D. Center Hung Pivots:

1. Unless otherwise noted, all patient toilet doors that swing into the toilet and require emergency hardware shall be furnished with a top and bottom center pivot. The bottom pivot leg shall be mortised into the frame. Where marble saddles are being installed, the bottom pivot shall be installed on top of the marble saddle.
 - a. Approved Manufacturers: NO SUBSTITUTIONS.
 - Rixson: 128 ¾ x US26D.

E. Continuous Hinges:

1. Unless otherwise noted, all continuous hinges shall be heavy gauge aluminum alloy with self-lubricating bearings.
 - a. Approved Manufacturers: NO SUBSTITUTIONS.
 - Roton: 780 series

1.2 Latching and Locking Devices

All automatic and manual sliding doors that are installed within egress exit corridors shall be self-latching. Refer to applicable codes for further information.

A. Mortise Locks and Latches:

1. Unless otherwise noted, all latchsets and locksets shall be heavy duty mortise type conforming to ANSI A156.13 Grade 1. Furnish a wrought steel box strike and a curved lip strike with each unit. All locksets are to be ordered less cylinder.
 - a. Approved Manufacturers: NO SUBSTITUTIONS.
 - Sargent: 8200 series x LL lever and rose x US26D.
 - b. Lock Functions are as follows:
 - Office Function: Sargent 8205 x LL x US26D.
 - Passage Function: Sargent 8215 x LL x US26D.
 - Privacy Function: Sargent 49-8265 x LL x US26D.
 - (Specify at all single gang public toilets, staff toilets and all patient toilets)

Privacy Function: Sargent 8265 x LL x US26D.
(Specify at all single gang patient toilets within patient bedrooms)

Classroom Function: Sargent 8237 x LL x US26D.

Storeroom Lock: Sargent 8204 x LL x US26D.

B. Cylinders and Keying:

1. Unless otherwise noted, all cylinders shall be keyed to the existing ASSA large format interchangeable core keying system. The hardware supplier shall furnish all cylinders and temporary brass construction cores. The NYU Langone Lock Shop will furnish and install all permanent cores. The hardware supplier shall furnish 5 control keys and 5 construction keys to be used during construction. It shall be the GC/Hardware supplier's responsibility to return the temporary cores to the manufacturer.

***Contractor shall provide and install temporary cores as work requires; NYU Langone locksmith shall provide all permanent ASSA cylinders upon completion of the work. ***

- a. Approved Manufacturers: NO SUBSTITUTIONS.

ASSA: Keyed to the existing NYU Langone key system.

C. Cylindrical Locks at Existing Doors:

1. Unless otherwise noted, where new locksets/passage sets are to be installed in existing doors that have a cylindrical lock preparation, furnish a Yale AU5400 series x US26D. Lock function is to match existing lock function.

- a. Approved Manufacturers: NO SUBSTITUTIONS.

Yale: AU5400 x 1210-less core series x US26D.

D. Combination Locks:

1. Unless otherwise noted, furnish combination locks at all soiled and clean utility rooms, staff locker and staff work rooms, on-call rooms and other spaces as requested by the user of the space. Key as directed by the NYU Langone Lock Shop.

- a. Approved Manufacturers: NO SUBSTITUTIONS.

ALARM LOCK: DL2700-T2 x Schlage C Keyway x US26D.

E. Hospital Push Pull Latches:

1. Unless otherwise noted, furnish hospital push pull latch at all patient bedroom doors and other spaces as requested by the user of the space. Mount both paddles down (except for OR's). Backset to be 2 ¾".

- a. Approved Manufacturers: NO SUBSTITUTIONS.

Glynn Johnson: HL6 x US26D.

F. Exit Devices:

1. Unless otherwise noted, all exit devices to be Von Duprin 98 series, rim, mortise or surface vertical rod. Concealed vertical rod devices will not be permitted.
2. Where electrified exit devices are required for interface with security or automatic operators, furnish Von Duprin EL (electric latch retraction), Quiet Electrified Latch (QEL) and RX (request to exit) features. The use of a Von Duprin EPT10 (power transfer) and a PS873 series (power supply) is required.
 - a. Approved Manufacturers: NO SUBSTITUTIONS.

Von Duprin: 98 series x US26D.

G. Electric Locks:

1. Unless otherwise noted, electric locks shall be specified at all card access doors. Electric strikes may be permitted in certain applications. Electric locks shall be mortise type complying with 1.2A as listed above. Electric locks shall be specified to have a built-in request to exit switch.
2. The Architect shall include in their documents all wiring, power and control required to the electric lock and interface to other electrical equipment.
3. The Architect shall specify a fail secure lock typically (with a manual key over-ride). When a door is required to unlock in a fire condition or loss of power, specify a fail-safe electric lock.
 - a. Approved Manufacturers: NO SUBSTITUTIONS.

Sargent: 8270RX (Fail Safe) x LL x 24VDC x US26D.

Sargent: 8271RX (Fail Secure) x LL x 24VDC x US26D.

1.3 Door Closing Devices**A. Surface Mounted Door Closers:**

1. Unless otherwise noted, all surface mounted door closers shall meet ANSI A156.4 Grade 1 requirements. All closers shall be barrier free with a delayed action feature. Furnish all required brackets, filler plates and any others items required to ensure proper installation and operation.
2. All surface mounted door closers shall be installed so that closer bodies are positioned on room-side of doors to and from corridors, (i.e. In-swing doors shall be regular arm. Out-swing doors shall have a parallel arm.) Regular arm shall be used in connecting doors between rooms.

- a. Approved Manufacturers: NO SUBSTITUTIONS.

LCN: 4040XP-RW PA-689

LCN: 4040XP-HW PA 689 HOLD OPEN

LIFE SAFETY CLOSER SHALL BE LCN: 4040SE-24V

Note: NYU Langone – Long Island uses Norton door closers.

- b. Surface Mounted Door Closers shall be specified as follows:

Regular Arm Mount: Used on doors that swing into a space. The door closer will mount on the pull side of the door, 4040XP-REG.

Parallel Arm Mount: Used on doors that swing out of a space. The door closer will mount on the push side of the door, 4040XP-RW/PA.

Parallel Arm Mount with built-in stop: Used on doors that swing out of a space, where an auxiliary stop cannot be used. The door closer will mount on the push side of the door, 4040XP-CUSH.

B. Floor Closers:

- 1. Floor closers shall only be used where it is virtually impossible for a surface mounted closer to be used. Approval from NYU Langone must be received before specifying floor closers. Floor closers may be used without approval on all glass doors.

- a. Approved Manufacturers: NO SUBSTITUTIONS.

RIXSON: 27/28 AHO/NHO 26D

1.4 Door Stops

A. Wall and Floor Stops:

- 1. Unless otherwise noted, all door stops shall be wall mounted type, Trimco 1270WV series. Furnish appropriate concealed fasteners as required. Where wall stops cannot be installed, furnish Trimco W1211 floor stops.

- a. Approved Manufacturers: No other manufacturer’s products are approved.

Trimco, Rockwood and Ives.

B. Overhead Stops:

- 1. Unless otherwise noted, furnish overhead stops at doors where wall or floor stops will not work. Furnish a Rixson 2 series x US32D for all hollow metal doors and Rixson 1 series for all heavy duty doors.

- a. Approved Manufacturers: No other manufacturer’s products are approved.

Rixson and Glynn Johnson.

1.5 Protection Plates

A. Kick Plates:

1. Unless otherwise noted, furnish kick plates on all doors, with the exception of closet doors within rooms. Kick plates shall be 16" high x 2" less than door width x .050 thick x beveled three sides.
 - a. Approved Manufacturers: No other manufacturer's products are approved.

Trimco, Rockwood and Ives.

B. Mop Plates:

1. Unless otherwise noted, furnish mop plates on all doors, with the exception of closet doors within rooms. Mop plates shall be 6" high x 2" less than door width x .050 thick x beveled three sides.
 - a. Approved Manufacturers: No other manufacturer's products are approved.

Trimco, Rockwood and Ives.

C. Armor Plates:

1. Unless otherwise noted, furnish armor plates on all doors that are subject to heavy abuse. Armor plates shall be 34" high x 2" less than door width x .050 thick x beveled three sides. Armor plates furnished on fire-rated doors must have a UL listing.
 - a. Approved Manufacturers: No other manufacturer's products are approved.

Trimco, Rockwood and Ives.

1.6 Flush Bolts

A. Automatic Flush Bolts:

1. Furnish automatic flush bolts on both fire-rated and non fire-rated pairs of doors where there is an inactive leaf.
 - a. Approved Manufacturers: No other manufacturer's products are approved.

Ives: FB31P-12-MD-32D for all metal doors

Ives: FB41P-WD-US32D for all wood or composite doors

B. Manual Flush Bolts:

1. Manual flush bolts shall not be permitted.

1.7 Automatic Operators

1. Unless otherwise noted, all Automatic Operators shall be Stanley Magic Force surface mounted. Specify all associated products required to meet ANSI A156.10.
2. The Architect shall specify that all automatic operators be furnished and installed by a Stanley authorized installer. The same automatic operator provider and installer shall also furnish and install all electronic locking hardware, as may be required, for all automatic operated doors.
3. The Architect shall include in their documents all wiring, power and control required to the automatic operator and accessories.
 - a. Approved Manufacturers: NO SUBSTITUTIONS.
STANLEY: Magic Force x Alum.
4. The Architect specify automatic operators on:
 - a. ALL Clinical Building Exterior Doors,
 - b. ALL Clinical Departmental Entrances, and/or
 - c. Doors between waiting areas/rooms and clinical areas beyond where the patient population is likely to have either mobility issues (i.e. orthopedics, rheumatology, rehabilitation, ophthalmology, etc.) or where stroller use is anticipated.

1.8 Card Access Doors

1. The Architect shall coordinate all security and electrical requirements with the security consultant and the electrical engineer. Where card readers are furnished, an electric lock with built-in request to exit switch shall be installed (see 1.2.G above). The Architect shall indicate which doors are required to have door and frame preparation for door contacts.

2.1 Typical Hardware Sets (by Room Type)

- A. The following is a general listing of hardware requirements and is not intended for use as a final hardware specification. It shall be the responsibility of the Architect to specify any items of hardware required by established standards or practices, or to meet state and local codes or proper door operation. Coordinate final door hardware requirements with user-groups.

This hardware set is used for doors to suite offices that are non fire-rated.

Each to have:

	Hinges	(see description) x US26D
1	Office Lock	Sargent 8205 x LL x LC x US26D
1	Cylinder	Assa (see description) x US26D
1	Temporary Core	Assa (see description) x US26D
1	Permanent Core	(by NYU Langone Lock Shop)
1	Stop	(see description) x US32D
3	Silencers	Trimco 1229A

This hardware set is used for doors to offices that are fire-rated.

Each to have:

	Hinges	(see description) x US26D
1	Office Lock	Sargent 8205 x LL x LC x US26D
1	Cylinder	Assa (see description) x US26D
1	Temporary Core	Assa (see description) x US26D
1	Permanent Core	(by NYU Langone Lock Shop)
1	Closer	LCN 4040XP series x 689
1	Stop	(see description) x US32D
1	Gasketing	Legacy 5881S-BK @ jamb/head

This hardware set is used for doors to public or staff toilets that are non fire-rated and fire-rated.

Each to have:

	Hinges	(see description) x US26D
1	Privacy Set	Sargent 49-8265 x LL x US26D
1	Closer	LCN 4040XP series x 689
1	Stop	(see description) x US32D
1	Kick Plate	(see description) x US32D
3	Silencers	Trimco 1229A

Note: NYU Langone – Long Island uses Arrow and Sargent privacy sets.

This hardware set is used for doors to patient toilets within a patient room that swing out of the toilet.

Each to have:

	Hinges	(see description) x US26D
1	Spring Hinge	(to match) x US26D
1	Passage Set	Sargent 8215 x LL x US26D
1	Stop	(see description) x US32D
1	Kick Plate	(see description) x US32D
1	Mop Plate	(see description) x US32D
1	Gasketing	Legacy 5881S-BK @ jambs/head

This hardware set is used for doors to patient toilets within a patient room that swing into the toilet.

Each to have:

1	set Pivots	Rixson 127 ¾ x US26D
1	Passage Set	Sargent 8215 x LL x US26D
1	Emergency Release	Stanley ES-1 x US26D
1	Double Lip Strike	Stanley DLS series x US26D
1	Stop	(see description) x US32D
2	Kick Plates	(see description) x US32D
2	set Sight Seals	Zero 335A @ wood doors
2	set Sight Seals	Zero 137P @ metal doors

Note:

- Sight seals to be installed at pivot side and lock side of door only.
- Where marble saddles are used, mount pivot set on top of the marble saddle.
- Saddles shall have no lip, even if permissible by code, as patients cannot navigate with IV pole.

This hardware set is used for doors to conference rooms, consulting rooms, and administrative staff lounges that are non fire-rated.

Each to have:

	Hinges	(see description) x US26D
1	Passage Set	Sargent 8215 x LL x US26D
1	Stop	(see description) x US32D
3	Silencers	Trimco 1229A

This hardware set is used for doors to conference rooms, consulting rooms, and administrative staff lounges that are fire-rated.

Each to have:

	Hinges	(see description) x US26D
1	Passage Set	Sargent 8215 x LL x US26D
1	Closer	LCN 4040XP series x 689
1	Stop	(see description) x US32D
1	Gasketing	Legacy 5881S-BK @ jambs/head

This hardware set is used for doors to utility type rooms that are non fire-rated and fire-rated and do not require access control.

Each to have:

	Hinges	(see description) x US26D
1	Storeroom Lock	Sargent 8204 x LL x LC x US26D
1	Cylinder	Assa (see description) x US26D
1	Temporary Core	Assa (see description) x US26D
1	Permanent Core	(by NYU Langone Lock Shop)
1	Closer	LCN 4040XP series x 689
1	Stop	(see description) x US32D
1	Kick Plate	(see description) x US32D
3	Silencers	Trimco 1229A @ non fire-rated doors
1	Gasketing	Legacy 5881S-BK @ jambs/head @ fire-rated doors

This hardware set is used for double doors to utility type rooms that are non fire-rated and do not require access control.

Each to have:

	Hinges	(see description) x US26D
2	Automatic Flush Bolts	(see description) x US26D
1	Storeroom Lock	Sargent 8204 x LL x LC x US26D
1	Cylinder	Assa (see description) x US26D
1	Temporary Core	Assa (see description) x US26D
1	Permanent Core	(by NYU Langone Lock Shop)
2	Closer/Hold Open	LCN 4040XPH x 689
1	Coordinator	Trimco 3094 series x 689
1	Stop	(see description) x US32D
2	Kick Plate	(see description) x US32D
2	Silencers	Trimco 1229A

This hardware set is used for double doors to utility type rooms that are fire-rated and do not require access control.

Each to have:

	Hinges	(see description) x US26D
2	Automatic Flush Bolts	(see description) x US26D
1	Storeroom Lock	Sargent 8204 x LL x LC x US26D
1	Cylinder	Assa (see description) x US26D
1	Temporary Core	Assa (see description) x US26D
1	Permanent Core	(by NYU Langone Lock Shop)
2	Closer	LCN 4040XP series x 689
1	Coordinator	Trimco 3094 series x 689
1	Stop	(see description) x US32D
2	Kick Plate	(see description) x US32D
1	Gasketing	Legacy 5881S-BK @ jambs/head
2	Astragal Seals	Legacy 799A

This hardware set is used for doors to closets within rooms that are non fire-rated.

Each to have:

	Hinges	(see description) x US26D
1	Storeroom Lock	Sargent 8204 x LL x LC x US26D
1	Cylinder	Assa (see description) x US26D
1	Temporary Core	Assa (see description) x US26D
1	Permanent Core	(by NYU Langone Lock Shop)
1	Stop	(see description) x US32D
3	Silencers	Trimco 1229A

This hardware set is used for doors to patient rooms.

Each to have:

	Swing Clear Hinges	(see description) x US26D
1	Hospital Push Pull Latch	GJ (see description) x US26D
1	Friction OH Stop	Rixson 1 or 9 series x US32D
1	Armor Plate	(see description) x US32D
1	Mop Plate	(see description) x US32D
3	Silencers	Trimco 1229A

This hardware set is used for doors to patient isolation rooms.

Each to have:

	Swing Clear Hinges	(see description) x US26D
1	Hospital Push Pull Latch	GJ (see description) x US26D
1	Closer	LCN 4040XP series x 689
1	Stop	(see description) x US32D
1	Armor Plate	(see description) x US32D
1	Mop Plate	(see description) x US32D
3	Silencers	Trimco 1229A

This hardware set is used for doors to exam rooms that are non fire-rated.

Each to have:

	Hinges	(see description) x US26D
1	Passage Set	Sargent 8215 x LL x US26D
1	Stop	(see description) x US32D
3	Silencers	Trimco 1229A

This hardware set is used for doors to exam rooms that are fire-rated.

Each to have:

	Hinges	(see description) x US26D
1	Passage Set	Sargent 8215 x LL x US26D
1	Closer	LCN 4040XP series x 689
1	Stop	(see description) x US32D
1	Kick Plate	(see description) x US32D
1	Gasketing	Legacy 5881S-BK @ jambs/head

This hardware set is used for all clinical staff lounges, medication rooms, on-call rooms, soiled and clean linen rooms, clinical break rooms and any other space that is user required.

Each to have:

	Hinges	(see description) x US26D
1	Combination Lock	(see description) x US26D
1	Cylinder	Schlage (see description) x US26D
1	Closer	LCN 4040XP series x 689
1	Stop	(see description) x US32D
1	Kick Plate	(see description) x US32D
3	Silencers	Trimco 1229A

This hardware set is used for all lead lined doors.

Each to have:

	set Pivots	Top and Bottom Rixson Pivot set L-147/ Center Pivot if needed ML-19
1	Classroom Lock	Sargent 8237 x LL x LC x US26D
1	Cylinder	Assa (see description) x US26D
1	Temporary Core	Assa (see description) x US26D
1	Permanent Core	(by NYU Langone Lock Shop)
1	Closer	LCN 4040XP series x 689
1	Stop	(see description) x US32D
1	Kick Plate	(see description) x US32D
3	Silencers	Trimco 1229A

Note:

- If doors are non fire-rated, furnish hold open closers.
- Lock to be lead wrapped.

2.2 Typical Electrical Hardware Sets (by Door Type)

A. The following is a general listing of electrical hardware sets. Coordinate with electrical engineer, security vendor and fire alarm vendor.

This hardware set is used for all single doors with automatic operators no latching (see wiring diagram E1)

Each to have:

- | | | |
|---|--------------------|---|
| 1 | Continuous Hinge | Zero 910DBAA x CE4 (CE4 is for Presence Sensor) |
| 1 | set Push Pulls | Trimco 1894-4B x US32D |
| 1 | Automatic Operator | Stanley Magic Force x Alum |
| 2 | Presence Sensors | BEA Super Scan |
| 2 | Wall Actuators | WIKK x 4 x 4-2 x US32D |
| 1 | Door Stop | Trimco (as required) x US26D |
| 1 | Armor Plate | Rockwood (see description) x US32D |
| 1 | Mop Plate | Trimco (as required) x US32D |
| 3 | Silencers | Trimco 1229A |

Operation:

Wall actuator on either side signals automatic operator to open door. Free egress at all times.

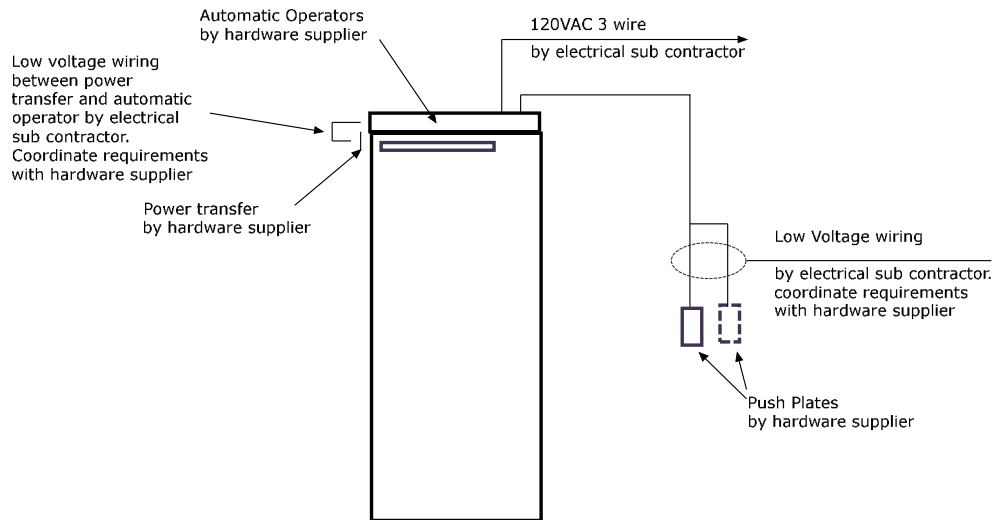

OPERATION: Push Plate on either side of the door signals automatic operator to open door. Safety sensors prevent door from opening when someone is standing in front of door.

PROJECT: NYULMC	DRWG #	DATE
Automatic Door No Latching (Single)	E1	8-20-10

This hardware set is used for all double doors with automatic operators no latching (see wiring diagram E2)

Each to have:

- | | | |
|---|--------------------|--|
| 2 | Continuous Hinge | Zero 910DBAA x CE4
(CE4 is for Presence Sensor) |
| 2 | sets Push Pulls | Trimco 1894-4B x US32D |
| 1 | Automatic Operator | Stanley Magic Force x Alum |
| 2 | Presence Sensors | BEA Super Scan |
| 2 | Wall Actuators | WIKK x 4 x 4-2 x US32D |
| 2 | Door Stop | Trimco (see description) x US26D |
| 2 | Armor Plate | Trimco (see description) x US32D |
| 2 | Mop Plate | Trimco (as required) x US32D |
| 2 | Silencers | Trimco 1229A |

Operation: Wall actuator on either side signals automatic operator to open door. Free egress at all times.

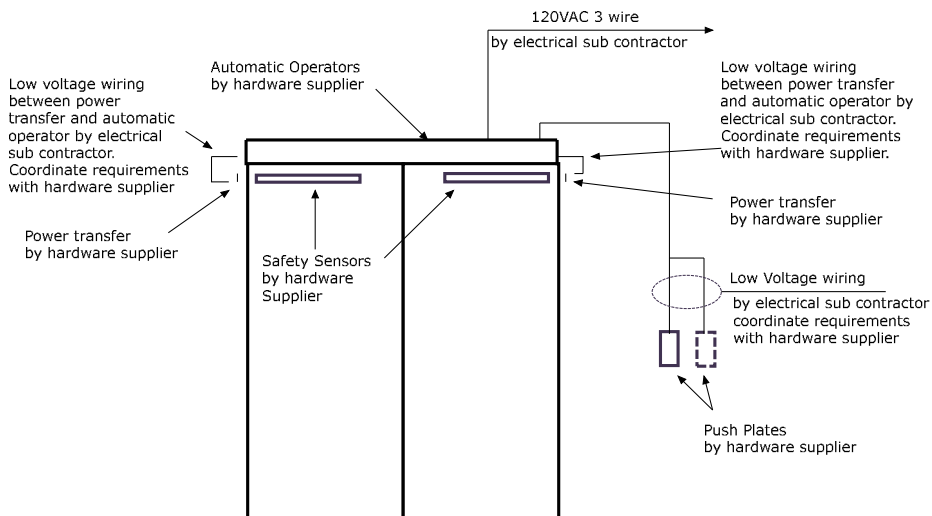

OPERATION: Push Plate on either side of the door signals automatic operator to open door. Safety sensors prevent door from opening when someone is standing in front of door.

PROJECT: NYULMC	DRWG #	DATE
Automatic Door No Latching (Pair)	E2	8-20-10

This hardware set is used for all single doors with card access (see wiring diagram E3)

Each to have:

- | | | |
|---|----------------|--|
| | Hinges | PBB (as required) x US26D |
| 1 | Electric Hinge | PBB 4 wire (to match) x US26D |
| 1 | Electric Lock | Sargent RX8271 x LL x US32D |
| 1 | Door Closer | LCN |
| 1 | Door Stop | Trimco (see description) x US26D |
| 1 | Kick Plate | Trimco (see description) x US32D |
| 3 | Silencers | Trimco 1229A @ non fire-rated doors |
| 1 | Gasketing | Legacy 5881S-BK @ jambs/head
@ fire-rated doors |
| 1 | Door Contact | (by security vendor) |
| 1 | Card Reader | (by security vendor) |

Operation:

Non Secure Side: Card reader unlocks electric lock.

Secure Side: Free egress. RX switch in electric lock shunts alarm.

Emergency Operation:

Non Secure Side: Door remains locked.

Secure Side: Free egress.

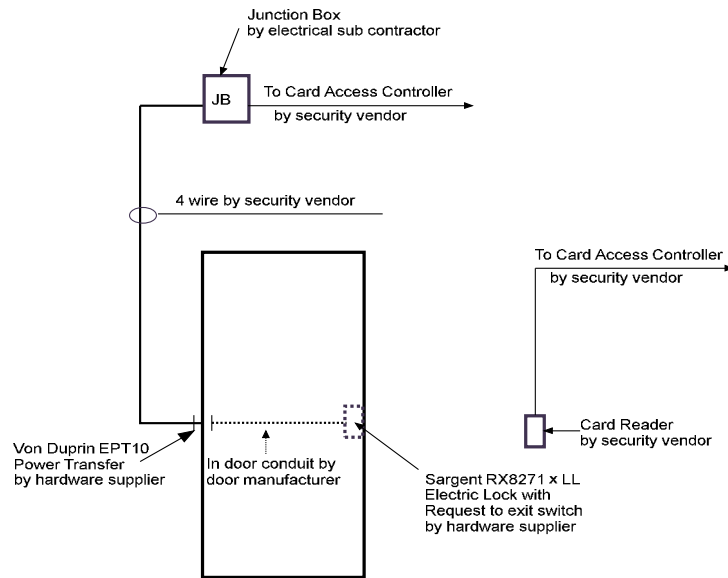

OPERATION: Card reader outside unlocks electric lock. Free egress inside. request to exit switch in lockset shunts alarm

PROJECT: NYULMC	DRWG#	DATE
Card Reader-Electric Lock with Request to Exit Switch	E3	8-20-10

This hardware set is used for all double doors with card access (see wiring diagram E4)

Each to have:

- | | | |
|---|-----------------------|--|
| | Hinges | PBB (as required) x US26D |
| 1 | Electric Hinge | PBB 4 wire (to match) x US26D |
| 1 | Electric Lock | Sargent RX8271 x LL x US32D |
| 2 | Automatic Flush Bolts | (see description) x US26D |
| 2 | Closer | LCN 4040XP series x 689 |
| 1 | Door Stop | Trimco (see description) x US26D |
| 2 | Kick Plate | Trimco (see description) x US32D |
| 2 | Silencers | Trimco 1229A @ non fire-rated doors |
| 1 | Gasketing | Legacy 5881S-BK @ jambs/head
@ fire-rated doors |
| 2 | Astragal Seals | Legacy 799A @ fire-rated doors |
| 2 | Door Contact | (by security vendor) |
| 1 | Card Reader | (by security vendor) |

Operation:

Non Secure Side: Card reader unlocks electric lock.

Secure Side: Free egress. AE switch in electric lock shunts alarm.

Emergency Operation:

Non Secure Side: Door remains locked.

Secure Side: Free egress.

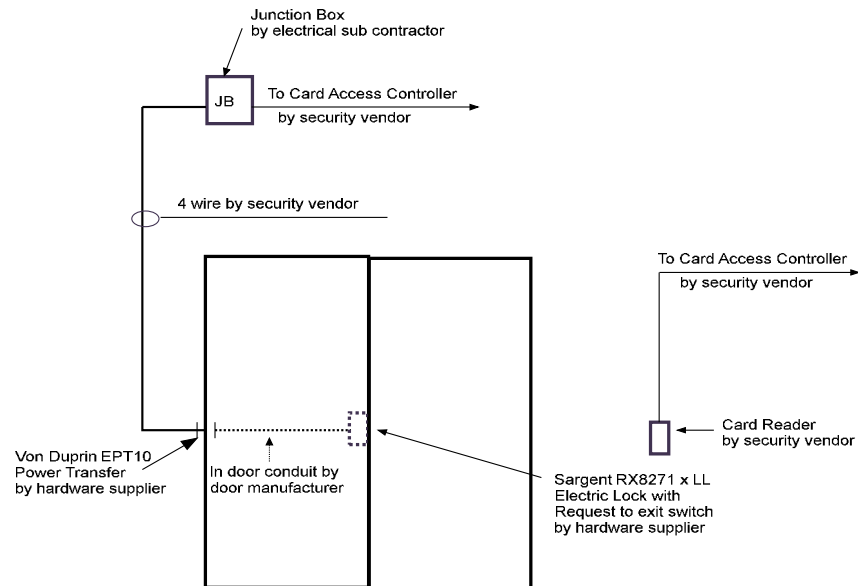

OPERATION: Card reader outside unlocks electric lock. Free egress inside. request to exit switch in lockset shunts alarm

PROJECT: NYULMC	DRWG #	DATE
Double Door Card Reader-Electric Lock with Request to Exit Switch	E4	8-20-10

This hardware set is used for all double egress doors with card access (see wiring diagram E5)

Each to have:

2	Continuous Hinge	Zero 910DBAA x CE4 x EPT Note: CE4 is for the Presence Sensor and the EPT cutout is for the Electric Power Transfer
2	Electric Exit Devices	Von Duprin ELRX 9827EO-F x LBR x US26D
2	Automatic Operators	Stanley Magic Force x Alum
1	Wall Actuator (Inside)	WIKK x 4 x 4-2 x US32D
4	Kick Plates	Trimco (see description) x US32D
2	Silencers	Trimco 1229A @ non fire-rated doors
1	Gasketing	Legacy 5881S-BK @ jambs/head @ fire-rated doors
1	Astragal Seals	Legacy DE-FMA @ fire-rated doors
2	Magnetic Locks	Deltrex 810-DS x Alum
1	Power Supply	Von Duprin PS873-2
1	Relay Module	Deltrex 530-2ARCM2
2	Door Contacts	(by security vendor)
1	Motion Sensor	(by security vendor)
1	Card Reader	(by security vendor)

Operation:

During normal operation, electric exit devices are electrically dogged to allow for automatic operators to open doors freely. Magnetic locks secure doors. When signaled from the fire alarm system, or loss of power, electric exit devices latch, automatic operators are shut off and magnetic locks unlock.

Non Secure Side: Card reader unlocks magnetic lock and signals automatic operator to open both doors.

Secure Side: Free egress. Wall actuator unlocks magnetic lock and signals automatic operator to open both doors.

Emergency Operation:

Non Secure Side: Door remains locked.

Secure Side: Free egress.

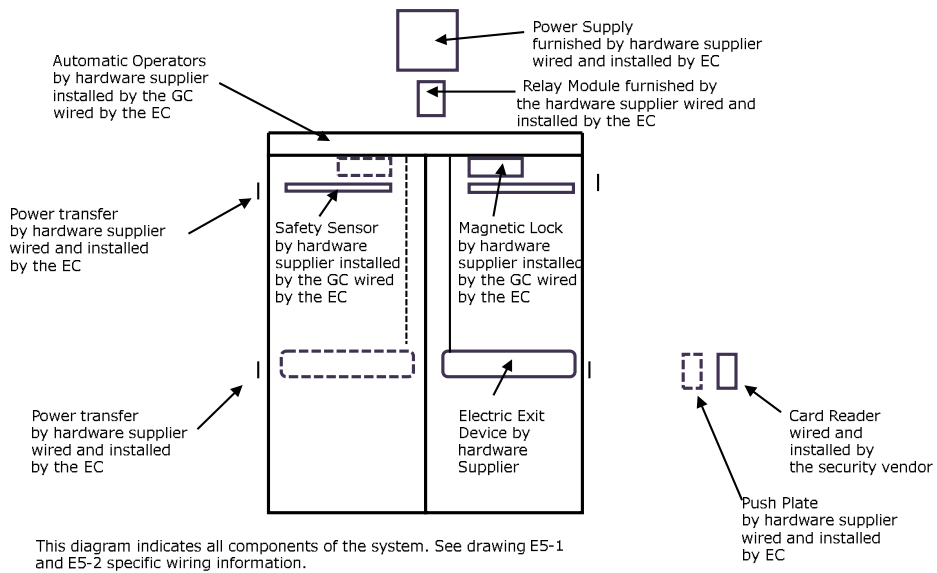

PROJECT: NYULMC	DRWG#	DATE
Cross Corridor Automatic Doors with Card Readers and Magnetic Locks	E5	8-20-10

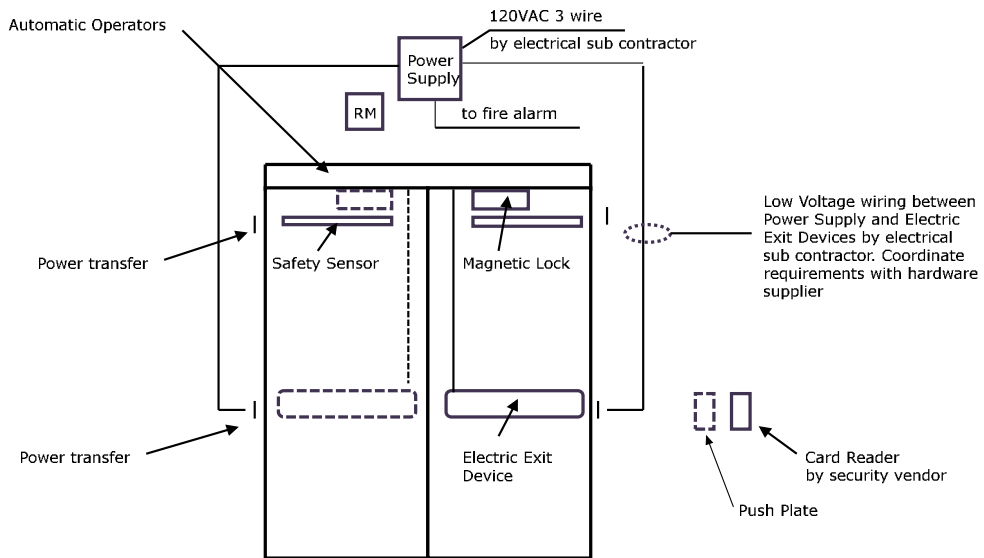

The wiring shown on this diagram is only for the electric exit device system.

PROJECT: NYULMC	DRWG #	DATE
Cross Corridor Automatic Doors with Card Readers and Magnetic Locks	E5-1	8-20-10

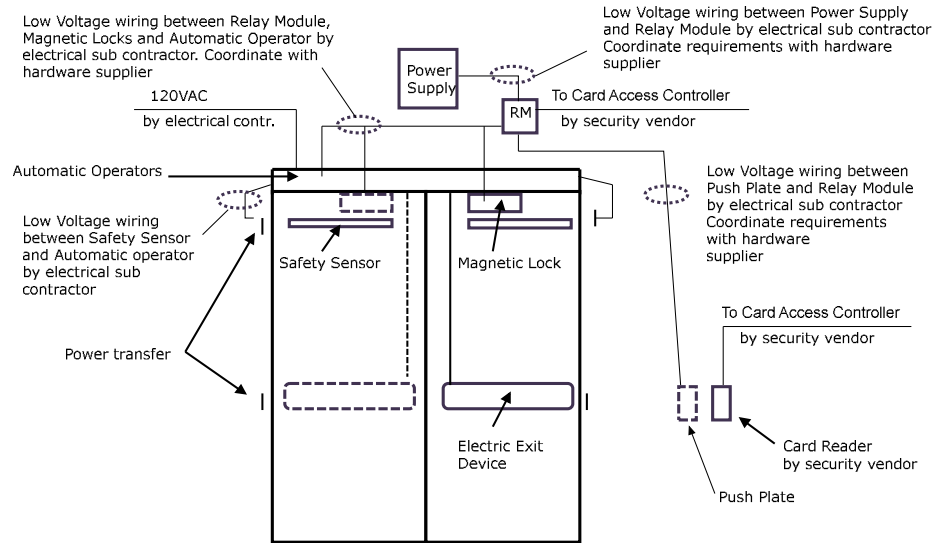

The wiring shown on this diagram is only for the automatic operator and card access interface.

PROJECT: NYULMC	DRWG #	DATE
Cross Corridor Automatic Doors with Card Readers and Magnetic Locks	E5-2	8-20-10

This hardware set is used for all single locked stair doors (see wiring diagram E6)

Each to have:

- | | | |
|---|----------------|----------------------------------|
| | Hinges | PBB (as required) x US26D |
| 1 | Electric Hinge | PBB 4 wire (to match) x US26D |
| 1 | Electric Lock | Sargent RX8270 x LL x US32D |
| 1 | Closer | LCN |
| 1 | Door Stop | (see description) x US32D |
| 1 | Kick Plate | Trimco (see description) x US32D |
| 1 | Power Supply | Deltrex 551CCM-ERI |
| 1 | Gasketing | Legacy 5881S-BK @ jambs/head |

Operation:

Stair Side: During normal operation, doors are locked electrically from the stair side. When signaled from the fire alarm system, or loss of power, electric lock unlocks automatically.

Egress Side: Free Egress at all times.

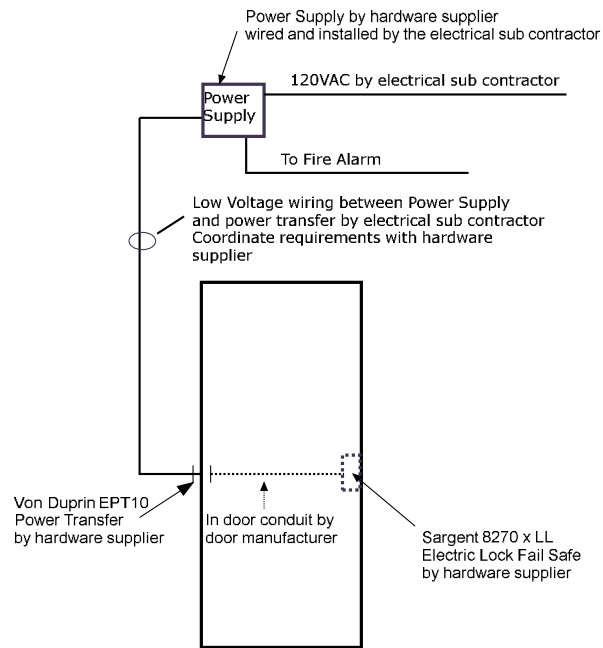

OPERATION: During normal operation stair doors are locked on the stair side. When signaled from the fire alarm system or loss of power, electric lock unlocks to allow re-entry.

PROJECT: NYULMC	DRWG #	DATE
Stair Door Fail Safe Electric Lock	E6	8-20-10

ENVIRONMENTAL HEALTH & SAFETY

NYU Langone Health’s Environmental Health and Safety (EH&S) division develops and manages programs that (1) protect personnel in all departments and on all levels from health and safety hazards, (2) ensure waste is discarded in an environmentally sound manner and (3) facilitate compliance with regulatory requirements for environmental and occupational health and safety. EH&S’s programs cover a broad spectrum of health and safety issues, including but not limited to: asbestos, biosafety, bulk storage tanks, chemical safety, ergonomics, fire safety, hazard communication, hearing conservation, indoor air quality, laboratory and animal safety, mold prevention and remediation, and waste management.

1. *Architect’s Responsibilities*

The A/E Team, to the best of their ability, shall incorporate Best Management Practices for environmental and occupational health and safety into the design of the space. The A/E Team responsibilities include:

- Anticipating, identifying and eliminating potential health and safety hazards (i.e. ergonomics, hazardous materials, noise, etc.) associated with the proposed use of the space, to the extent reasonably practical.

Note: Eliminating hazards is not intended to limit creativity, but to ensure the designer minimizes foreseeable risks to the health and safety of those who:

- Carry out construction work, including demolition.
 - May be affected by the project, including building occupants and the general public.
 - Occupy the space post-construction.
 - Clean and maintain the space.
- Specifying the least toxic, flammable/combustible and reactive products available for construction and renovation.
 - Where health and safety hazards cannot be eliminated, proposing alternate engineering controls to minimize or eliminate the risk.
 - The A/E Team shall use and comply with the design and safety regulations, guidelines and references listed in the References subsection below, as well as other health and safety guidelines received from NYU Langone’s Project Manager or division of EH&S. The A/E Team shall utilize the latest editions of the references available at the time of the design contract award.
 - If the design does not incorporate Best Management Practices for environmental and occupational health and safety, and comply with the References listed below, the A/E design firm shall obtain approval from NYU Langone’s division of EH&S.
 - The A/E Team shall not specify any of the following without approval from NYU Langone’s division of EH&S:
 - Chemical products containing known (IARC group 1) or probable (IARC group 2a) human carcinogens*.
 - Chemical products containing toxic and hazardous substances listed in OSHA 1910 subpart Z*.

- Chemical products containing volatile organic compounds (VOCs) in excess of 50 grams/liter.
- Chemical products for which the Safety Data Sheet (SDS) rates the health, fire or reactivity hazard as greater than “1” (slight hazard) on the NFPA/HMIS scale or as less than “4” (slight hazard) on the GHS hazard scale.
- Chemical products which emit strong odors.

* Exceptions may be made for products containing chemicals which do not pose a hazard to persons during their application/use (i.e. paints containing silica).

- In order to minimize potential delays associated with asbestos abatement, the A/E Team shall submit a set of Design Development Drawings that identify the scope of work including 100% complete Demolition Drawings. The Demolition Drawings shall provide sufficient information to initiate an asbestos investigation and pull a demolition permit. The Demolition Drawings submitted shall be the same drawings that are filed with the DOB.
- The A/E Team shall confirm requirements for code required emergency/egress signage (i.e. stair and elevator fire egress maps and messaging) and health/safety signage (i.e. chemical, laboratory, hazardous material, radiation, etc.) with Environmental Health & Safety (EH&S) at RED+F.

2. *References (A/E Team to confirm applicable local, state and federal code requirements)*

Federal Regulations	Consensus Standards
<ul style="list-style-type: none"> - US DHHS - US DOL OSHA 1910 and 1926 - US EPA - US FDA - US NRC 	<ul style="list-style-type: none"> - ACGIH - ANSI - ASHRAE - ASTM - BOCA - NFPA
State Regulations	Ergonomics
<ul style="list-style-type: none"> - NYS DEC - NYS DOH - NYS DOL - NYS Building and Fire Codes 	<ul style="list-style-type: none"> - Facilities Guidelines Institute (FGI): Patient Handling and Movement Assessments: A White Paper - NIH Design Requirements Manual - NIOSH - OSHA - ICC A117.1, ANSI - 2010 ADA Standards for Accessible Design, Dept of Justice - ANSI/HFES 100-2007
Local Regulations	
<ul style="list-style-type: none"> - NYC Building and Fire Codes - NYC DEP - NYC DOH 	
NYU Langone Standards	Noise
<ul style="list-style-type: none"> - Safety Policy Manual - Radiation Safety Manual 	<ul style="list-style-type: none"> - NSF - TJC

ENVIRONMENTAL SUSTAINABILITY

NYU Langone Health believes that healthy people and a healthy environment are inextricably linked. As a healthcare organization, it is imperative that we act as a community leader in environmental stewardship. Creating a vital and healing environment is also central to our mission devoted to excellence in patient care, education, and research and is integral to the comfort and lifelong wellness of our staff, students and patients. This sustainability commitment extends across every facet of NYU Langone, including how we design, construct and operate our facilities. Furthermore, the health system recognizes the risks associated with climate change and has committed to being a carbon neutral health system by 2050 with an interim 50% carbon reduction goal by 2030.

The goal of NYU Langone’s sustainability program is to fulfill a quadruple bottom line approach where decision-making is based on balancing the potential impacts on people, the planet, business economics and patient care. The goal is not only to design green buildings and use environmentally-preferable materials, but to augment our benefit to the community and reduce the negative environmental and human wellness impacts of operations once occupied. Teams should ensure projects exemplify our key sustainability pillars of emissions mitigation, adaptation and resiliency to climate change, health promotion and demonstration of leadership. In line with that commitment we are providing additional information about NYU Langone’s sustainability program organized as follows:

1. Sustainable Building Design Guidelines
2. Green Roof and Solar PV Guidelines
3. Sustainable Furniture and Furnishings Guidelines
4. Sustainable Flooring Guidelines
5. Bicycle Transportation Guidelines
6. Electric Vehicle Infrastructure Guidelines
7. Building Energy Efficiency Rating Label Guidelines
8. Related Components or Policies

More can be read about the scope and progress of NYU Langone’s sustainability program, called GreenFirst, at <http://nyulangone.org/our-story/sustainability>.

1. *Sustainable Building Design Guidelines*

For all **new construction and major renovation (more than 25,000 square feet or projects that include significant MEP scope)**, NYU Langone has instituted a goal of achieving Gold or higher level certification under the LEED v4 or v4.1 ratings system. Projects should assess the appropriate project type including BD+C, ID+C or others that may apply. Designers are to discuss the LEED and energy performance requirements with RED+F Project Managers from the outset and to follow an integrative design process. Where achievement of these goals presents significant hurdles for a project, the requirements should be discussed with the RED+F Project Manager, RED+F Leadership, and the Energy & Sustainability Program Manager early during the design process. Good communication of goals, requirements and challenges will help all projects achieve the highest levels of performance and innovation while containing costs.

Designers shall assist NYU Langone Health with preparation of the Owner’s Project Requirements (OPR). The OPR shall outline the Project’s environmental and sustainability goals and measures, waste and recycling requirements, energy performance requirements, and other system expectations. A template OPR can be provided by the Energy & Sustainability Program Manager. It shall be reviewed and approved by the RED+F PM and the Energy & Sustainability Program Manager. This information is mandatory for LEED certification and will be reviewed by the commissioning agent.

If an option, projects must also complete a NYSERDA or whole building energy model simulation as part of meeting its LEED goals and take advantage of available funding or incentives for this work. This can include utility, State or Federal incentives including those outlined for either direct pay or Tax Credit (through the design professional) in the Inflation Reduction Act of 2022. In addition, projects that are 25,000 sq. ft. or greater and within New York City shall comply with Local Law 97. Such projects shall include a review of energy performance, carbon emissions and life cycle costs. The life cycle cost review shall include energy costs, operating costs and potential future LL97 or other penalties using a moderate approach to carbon coefficients after 2034. The A/E Team may consult with the Energy & Sustainability team regarding reasonable assumptions, space type assignments, campus carbon accounting, and any other aspects of LL97 as needed.

For **fit-outs, interior-only and smaller projects**, the LEED and energy goals should be discussed with the RED+F Project Manager, RED+F Leadership, and the Energy & Sustainability Program Manager at the outset of the design process to establish requirements and goals on a case by case basis.

Other guidelines or certification standards that NYU Langone encourages project developers to take into consideration include the WELL Building Standard, the NYC Active Design Guidelines: Promoting Physical Activity and Health in Design, the CDC’s Fitwel standard, My Green Labs certification and resources from the International Institute for Sustainable Laboratories (www.i2SL.org).

NYU Langone believes that LEED and green buildings aim to protect, restore and work in harmony with the local environment, existing transit infrastructure and underlying natural systems. In general, green buildings are energy efficient, water conserving, durable and nontoxic, with high-quality spaces that incorporate nature. NYU Langone seeks to integrate the following features of well-designed green buildings where possible and applicable:

- Demonstrate resiliency and adaptability in response to a changing climate and extreme weather events.
- Incorporate passive design strategies and maximize use of energy efficient infrastructure and renewable energy sources (with or without energy storage).
- Reduce or eliminate reliance on fossil fuels to reach carbon emissions reduction targets.
- Minimize building stormwater runoff by incorporating green roofs, gardens, permeable pavers, bioswells and other green infrastructure (GI) or low-impact development (LID) techniques as well as maintain compliance with NYC LL94 where applicable.
- Use native and adaptive plants that minimize landscaping and irrigation needs.

- Incorporate green and open spaces and provide access to the outdoors for patients and staff.
- Incorporate facilities and design that encourage the use of alternative transportation methods, particularly biking and public mass transit.
- Maximize use of natural lighting and provide views to the outside.
- Reduce impact of noise and vibration through use of professional acoustical analysis and design services.
- Provide for improved indoor air quality and minimize the use of chemicals of concern to increase the productivity of staff and reduce recovery time for patients.
- Minimize or eliminate the use of mercury-containing materials where safe, effective alternatives exist in compliance with NYU Langone Health Safety Policy 170.
- Focus on material health. This includes compliance with the Practice Greenhealth Healthcare Without Harm: Safer Chemicals Challenge, eliminating the use of formaldehyde, perfluorinated compounds, polyvinyl chloride (PVC), antimicrobials, and all flame retardants from all materials and finishes.
- Focus on material and product circularity. This includes materials and products that incorporate recycled, local and renewably sourced materials, and can be reused or upcycled at the end of life
- Provide well-incorporated waste and recycling segregation and bins using the built environment to encourage proper recycling behavior in occupants (see the Recycling Program subsection of these Design Guidelines)
- Support occupant mental and emotional health by implementing design strategies to ensure they are informed about their environment and have access to a variety of relaxation and social spaces.

An integrative design approach and a life cycle assessment approach are both essential to meet these guidelines and marry green building with sustainable operations and resiliency for the life of the facility. Finding synergies between the built environment and eventual operations is an important concept. For example, incorporation of a green roof feature can provide insulation and lower energy needs, help manage stormwater runoff on the campus and reduce the heat island effect in the NYC community. Or designing with the understanding that the flooring material used not only has an embedded energy, carbon and natural resource footprint, but that the type of material used impacts how the facility needs to be cleaned post-occupancy. Material decisions such as these can either facilitate or hinder a reduction in chemical and water usage as part of green cleaning practices. Or designing into the built environment smart waste sorting stations that cater to the type of activity (research, clinical or office) taking place in each space can ultimately drive employees to practice good recycling behaviors. By using an integrative project approach that brings in multiple stakeholders from the outset, project teams can more readily discover synergies and areas for true innovation.

2. *Green Roof and Solar PV Guidelines*

New York City Local Laws 92 and 94 of 2019 require all new and existing buildings undergoing major roof construction or renovation to have a green roof system, solar photovoltaic system, or a combination of both. The regulation also requires projects to meet new, higher solar reflective index (SRI) requirements.

Examples of projects affected include new construction, vertical or horizontal building extensions, and replacements of the entire roof deck or assembly.

Even when not required by code, Architects are encouraged to consider implementation of green roofs, solar photovoltaics or both on NYU Langone projects to take advantage of the benefits of sustainable roof systems as outlined below:

- Achieve points under USGBC LEED standards
- Improve resiliency and backup generation
- Lower energy costs either through direct offset or through better building insulation
- Feed additional distributed energy resources and renewables back into the grid
- Reduce the urban heat island effect
- Manage stormwater and runoff

3. *Sustainable Furniture and Furnishings Guidelines*

NYU Langone has committed to the Practice Greenhealth [Healthcare Without Harm: Safer Chemicals Challenge](#), which impacts furniture purchasing and design decisions. This goal means that at all purchases of freestanding furniture and medical furnishings¹ for any individual project are to be specified **without** the intentional use of the following chemicals of concern: halogenated and brominated flame retardants², formaldehyde, perfluorinated compounds, PVC (also known as vinyl) and antimicrobials³. Project teams should discuss with the RED+F Project Manager, RED+F Leadership, the RED+F Design Studio, and the Energy & Sustainability Program Manager throughout the process to meet these guidelines and evaluate feasibility.

For all projects, regardless of the level of certification or LEED ratings system being pursued, NYU Langone also encourages the use of locally-sourced furniture and textiles, furniture that contains pre or post-consumer recycled content and the use of wood that is FSC-certified.

Other standards or certifications to refer to include the ANSI/BIFMA e3 Furniture Sustainability Standard, SCS certified and Cradle to Cradle.

Notes:

¹ Furniture and medical furnishings include seating (i.e. chairs, stools, sofas, benches, etc.), worksurfaces (i.e. tables, desks, etc.), built-in and modular casework systems (i.e. walled desks with seating), beds (including mattresses), storage units (i.e. cabinets, filing cabinets, dressers, drawers, etc.), shelving (i.e. bookshelves, built-in shelves, etc.), panels and partitions, cubicle curtains, and window coverings.

² Eliminate the intentional use of all flame retardants where code permits. When flame retardant chemicals are necessary to meet code requirements, use chemicals that meet GreenScreen Benchmark 3 or 4 of their equivalent.

³ Triclosan and triclocarban are explicitly prohibited. No other added or built-in chemical antimicrobials are allowed unless they are registered with the U.S. EPA under the Federal Insecticide, Fungicide, and Rodenticide Act (FIFRA), and have published data that show efficacy in a hospital/clinical setting measured by a reduction in healthcare-associated infections (HIAs) as part of comprehensive infection control measures. Antimicrobials added to materials or products for the sole purpose of preserving the product are exempt.

4. *Sustainable Flooring Guidelines*

Some of the materials and chemicals used in flooring can make it a negative contributor to indoor air quality, lead to a wide range of adverse health effects including but not limited to asthma, cancer, and developmental impacts, and promote unsustainable cleaning practices. All capital projects, regardless of pursuit of requirements for LEED certification or other building rating systems, shall use flooring materials, coatings, and adhesives free of select chemicals of concern as dictated by Health Care Without Harm’s Healthy Flooring criteria (minimum silver level rating).

5. *Bicycle Transportation Guidelines*

The NYU Langone Bicycle Transportation Policy seeks to foster a bike-friendly culture with bike commuter amenities such as parking, security, safety and bike registration.

Inclusion of bike amenities shall be discussed with the RED+F Project Manager as well as representatives of the Real Estate team and the Sustainability Manager regardless of pursuit or requirements around LEED certification for a project as specified in these Design Guidelines. The Project shall provide adequate bike parking to meet end user daily demand.

- **Bike Parking and Amenities**

- **Indoor Bike Parking** - When provided indoors, bike parking shall be within secure bike parking rooms for use by approved staff, faculty and students. These rooms shall be accessible through a keycard reader.

For fit-outs within leased premises, the A/E Team shall follow the landlord’s rules for the management of indoor bike parking/storage within NYU Langone’s own premises. The Real Estate team can advise on a particular building’s policies.

- **Outdoor Bike Parking** - Outdoor bike parking may be located outside building entrances and exits, in parking lots or garage structures, within secure courtyards or on terraces. NYU Langone’s preference is for outdoor bike parking to be covered or protected from the outside elements.
- **Bike Commuter Shower Facilities** - If a project, particularly new construction, can accommodate male/female or a unisex individual shower facility, the A/E Team shall include them in the design.
- Refer to the Building Accessories subsection of these Design Guidelines for bike rack specifications.

6. *Electric Vehicle Infrastructure Guidelines*

Capital projects involving NYU Langone-owned car parking lots and garages shall provide a minimum of 5% of total parking spots to have EV chargers installed and ready for use with NYU Langone preferred software. An additional 5% of total parking spots shall have EV chargers installed and/or be EV Ready with the necessary power infrastructure installed to meet future demand. The A/E Team and RED+F PM shall coordinate related signage fabrication and installation with NYU Langone Design Studio’s Signage/Wayfinding Group as part of the capital project. This shall be discussed with the RED+F Project Manager as well as representatives of the Real Estate team and the Energy & Sustainability Program Manager.

7. *Building Energy Efficient Rating Label Guidelines*

New York City Local Law 33 of 2018 and 95 of 2019 require the display of an energy efficiency score and grade provided annually by the New York City Department of Buildings. This regulation applies to owned properties that are listed on the Covered Buildings List for benchmarking compliance as per Department of Finance records. Consult with NYU Langone Design Studio's Signage / Wayfinding Group to coordinate location and frame.

8. *Related Components or Policies*

- NYU Langone Health: Bicycle Transportation Policy
- NYU Langone Health Safety Policy 170: Mercury Elimination Program
- NYU Langone Health Safety Policy 108: Chemical Waste Minimization and Disposal Program
- NYU Langone Health Safety Policy 108a: Hazardous Waste from Contractors (Construction & Building Maintenance)
- NYU Langone Health Safety Policy 108c: Universal Waste Management Program

INFORMATION TECHNOLOGY

NYU Langone’s MCIT (Medical Center Information Technology) division is responsible for the planning, design, construction, implementation, and operational aspects of all information technology systems, inclusive of both clinical and non-clinical systems. Our mission is to ensure technology systems are deployed in a manner to improve patient outcomes, increase patient safety, and provide state-of-the-art platforms to conduct world-class medical research initiatives. MCIT is responsible for all aspects of IT spaces, including data center, BDF/IDF, and TER’s as well as the following IT systems: networking, cabling, telephony, audio/visual (AV), electronic medical record, nurse call, telemetry, end-user devices, and real-time location services (RTLS).

The standards listed below apply to IDF Rooms that are typically found in capital improvement projects. This guideline is a subset of a larger technology design standards document (*NYU Langone Health Medical Center Information Technology EPMO - Structured Cabling Standards and Best Practices*) and should be used in conjunction with the latest version of that document.

The purpose of the *NYU Langone Health Medical Center Information Technology EPMO – Structured Cabling Standards and Best Practices* is to provide specific criteria in the design and planning of technology spaces. It is intended to be used by internal and external project management administrators, project architects and engineers, as well as facility managers. It shall be referenced for specific guidelines, standards and specifications for the design, construction and commissioning of technology spaces and/or facilities. Any deviation from the *NYU Langone Health Medical Center Information Technology EPMO – Structured Cabling Standards and Best Practices* must be reviewed and approved by MCIT.

1. IDF - Planning Requirements

An IDF is a technology space provided on every floor in a NYU Langone building from which all horizontal services to users are served, including low-voltage data and voice services. On a floor, (1) one or more IDF Rooms will be provided, converging IT, AV, Security, BMS, RF, Nurse Call, Telemetry, Public Address, etc., into one room.

- **Quantity of IDFs** - A minimum of one (1) IDF per floor is required at all clinical and smaller non-clinical facilities. IDF quantities shall be based on the square footage of the floor and outlet density. TIA 569 recommends one (1) IDF per 10,000 square feet.
- **Location of IDFs** - IDFs (and BDF Rooms providing IDF functionality) shall be positioned to be within 250 feet of horizontal distance from the farthest outlet point (using right angle measurements). Final locations of all IDFs, including the intended primary path(s) of horizontal cabling and the associated 250 foot rule must be presented to and approved by MCIT prior to the architectural layout being approved by NYU Langone project management.

IDF Rooms shall be located on separate sides of the core, however, these rooms shall be positioned to provide maximum coverage to the entire floor.

IDFs located below the Design Flood Elevation (D.F.E.) shall only serve areas within the FEMA defined flood zone.

- IDF Rooms shall be stacked to maintain a vertical adjacency. Equipment that is not related to the support of the IDF (i.e. piping, conduits, duct work, etc.) should not be located in, or pass through, the IDF.
- **Room Size and Layout** - The room size is to be ultimately confirmed by the final determination of racks and cabinets, which must be identified for use by the IT Designer and approved by NYU Langone MCIT prior to coordination with the Architect. A minimum clearance of 36 inches is required around three sides of any cluster of racks.
 - **Rack Requirements** - Otronics Mighty Mo 20 is the preferred rack. It is 23.75" wide x 24" channel depth complete with dust cover and isolation pad kit. The preferred color is black. Preferred height shall be 7'-0", and shall only be reduced or increased based on room constraints.
 - **Unacceptable Occupancies or Uses above IDF's** - All use types that involve water supply and removal, such as kitchens, locker room showers, toilets, pantries, etc. shall not be permitted to be located above or adjacent to a technology room.
 - **Horizontal Pathways** - Space must be established by the IT Designer to account for horizontal cabling distribution, regardless of whether ladder rack is provided or not, as a means of cabling support. Sufficient clearance and access methods must also be included to facilitate future cabling changes. This path shall be presented to MCIT when the IDF locations are being submitted for preliminary approval.
 - **Raceways Penetrating Walls and Floors** - Where cabling is required to traverse rated walls and/or floors and is not to be routed in conduit, fire-rated Hilti Speed sleeves must be employed. Non-rated penetrations shall use the Hilti Smoke Sleeve. Hilti sleeves shall not be filled in excess of 60% fill. 40% spare capacity shall be provided for future use.

All sleeves which traverse rated walls and/or floors must be properly firestopped, where Hilti is not required or applicable by NYU Langone MCIT. Sleeves and conduits penetrating into technology spaces shall not exceed 4".

2. IDF - Electrical Requirements

- **UPS Power** - Refer to NYU Langone Electrical Guidelines.
- **PDU and Distribution Level Capacity** - PDU's shall not exceed 90% of rating. Capacity shall assume a total load on a PDU in the event one-half of a circuit in a 2N pair has failed.
- **Lighting** - 45 to 55 fc (450 to 550 lux)
- **Telecommunication Grounding** - A Telecommunications Grounding Busbar (TGB) must be provided in all technology rooms, mounted at 7'-6", and at a minimum, be connected to building structural steel or an already established telecommunications ground. The TGB is the grounding connection point for telecommunications systems and equipment. This should be shown on the electrical plans for electrician to install. The IT contractor shall bond the IDF equipment to the TGB.

All two-post racks shall utilize Chatsworth Rack Base Insulator Kits or Ortronics Cooper B-line Isolators to create isolation between floor slab/rebar and the metal of the technology equipment rack.

3. *IDF's – Mechanical Requirements* - Refer to NYU Langone Mechanical Guidelines.

4. *IDF's – Architectural Requirements*

- **Ceiling Construction** - No hung ceiling. Any exposed fireproofing shall be encapsulated in an appropriate material. All ceilings shall be painted white. No penetrations or sky lights over IT areas.

- **Floor Treatment** - All concrete surfaces shall be erosion and vapor sealed (i.e. oil-based paint, concrete coating, etc.). Provide Static Dissipative Floor Tile (SDT) installed as a system per manufacturer installation instructions. Grounding strips shall be connected to the TGB by the electrician. An electrical back-box shall be provided to accommodate this connection.

All floors above technology spaces shall be treated in the areas of the technology room to provide a waterproofing layer in order to prevent the migration of water to the technology room below.

- **Fire Rating** - As required by Code. (Perimeter Wall -2 hour minimum. Interior Walls – 1 hour minimum.)

All pipes, duct ladder racks, cable trays and conduit penetrations shall be fire-sealed at penetrations through rated walls.

- **Windows** - Fenestration (i.e. windows) at exterior walls is not permissible.
- **Finishes** - Paint over vapor barrier primer/sealer at perimeter walls and paint at interior walls. Coordinate paint specification with RED+F.
- **Walls** - Interior walls shall be insulated stud walls with gypsum board finish.
- **Plywood Backboard** - Provide fire-retardant plywood painted with two (2) coats of fire-retardant paint (white in color) on the major wall space.
- **Doors** - Where permissible, doors are to swing out and not have a threshold. Doors shall be a minimum 3'-0" width x 7'-0" height. All IDF doors shall be fitted with card access with electrified mortise lock with transfer hinge. Doors shall have a fire rating as required by code.

5. *IDF's – Miscellaneous Requirements*

Card readers required on door. Off-campus locations require remote access.

Provide (2) two CCTV cameras. One to monitor the door and front rack activity. The second to monitor activity at the rear of the racks. Camera locations shall be coordinated with Security and the MCIT PM.

6. *Miscellaneous IT Design Requirements*

Cable trays external to technology spaces are to be provided by the electrical contractor. They are to be designed by IT Designer and shown on the Electrical drawings. It is critical the cable tray path is coordinated with the MEP.

All IDFs require a dedicated pathway back to the BDF. This can take the form of a dedicated telecommunications shaft way, sleeves through the floors of stacked IDFs, and/or conduit runs. Sizing and routing should be determined by the Designer and approved by MCIT.

SECURITY

Given its location in the heart of New York City, NYU Langone pays special attention to security in its facilities and operations. In order to bring existing and new locations undergoing renovations in line with our security standards, new security components are required to be installed as additions to existing security systems or completely new installations. Security system design and installation will require varied approaches depending on the Project Type as outlined below:

1. Project Types

- **Facilities with Existing Security Systems** - In nearly all facilities that NYU Langone owns or leases, there is an existing security system to which follow-on installations will link and we will use that vendor's equipment for the follow-on installation. The vendor of that equipment is the Security Vendor. The RED+F PM and the A/E Team will work with the Security Vendor to develop equipment placement requirements and will meet with NYU Langone's Security Department at key points during the design and construction process for their review of the security design. Among other things, the Security Department will review the equipment the Security Vendor proposes to use and the pricing. The Security Vendor will work under contract to the construction contractor.
- **Facilities without Existing Security Systems** - If the facility is new, there will not be an existing Security Vendor. Accordingly, the Architect shall provide security design services or shall engage the services of a Security Consultant (pre-approved by NYU Langone's Security Department) to provide such services and the Architect will be responsible for the services the Security Vendor would otherwise provide. The project team will work with RED+F's Project Support Office to determine how to procure the Security Vendor. Alternatively, RED+F may direct the use of an existing Security Vendor.

2. Project Development and Design

The following are required milestones for meetings with NYU Langone to determine security needs, develop scope and coordinate final recommendations:

- **Schematic Design** - During Schematic Design a meeting with the A/E Team, RED+F's PM, User-Group leadership and any additional stakeholder(s) of the new space shall be held. The purpose of the meeting is to review security needs for the project.
- **Design Development** - During the Design Development Phase, the Architect shall provide Floor plans, Furniture plans, Reflected Ceiling plans and Door Hardware information to and meet with the Security Department and Security Vendor at the same time. The Architect will propose for Security Department approval a security system design that incorporates User-Group requests, Stakeholder requests, NYU Langone security standards and industry security standards.
- **Construction Documents** - During the Construction Document Phase, the Architect (through the RED+F PM) will organize a meeting of the A/E Team, Security Department, and RED+F's PM to review the proposed security solutions and seek Security Department approval thereof. The Security Vendor will provide the A/E Team with equipment cut

sheets, cabling and rough-in requirements. The A/E Team will incorporate this information into the Construction Documents. A final meeting will be held with the A/E Team, Security Department, RED+F's PM, User-Group leadership and any additional stakeholder(s) of the new space to present the final coordinated security design. The decision for systems cabling responsibility will also be determined at this time.

- ***“As-Built” Documentation*** - The Architect shall provide the Security Vendor and Security Department with copies of the finalized “As-Built” in electronic form acceptable for import into BuildFlow.

3. *General Requirements for Security Design*

The Architect shall follow the security requirements listed below in the design of the project:

- Any code issues, such as fire and life safety, that affect security operations must be addressed by the Architect.
- Interior
 - Common spaces should not be isolated from entrances or stairs.
 - Consider location of permanent staff in multiple locations within spaces to limit possibility of unoccupied spaces that cannot be monitored.
 - Consider use of interior glazing and other strategies to improve visibility and accessibility.
 - If a security officer post is included in the design, consider sightlines from the seated position.
- Security access control and alarm systems on the superblock must be compatible and integrated with the existing system at the NYU Langone Security Operations Center. Systems off the superblock will be evaluated on a case-by-case basis as to their need to be tied into the existing system or if they can be stand-alone and tied into a central station for monitoring and subsequent response.
- Cameras are required at all lobbies, laundry rooms, cash handling areas, elevators, stair doors, entrance and egress doors, as well as any other areas as recommended by NYU Langone Health.
- All windows should be lockable.
- A/E Team should alert NYU Langone Health to security conditions that are not immediately apparent but would have operational impact, such as emergency egress doors that are on hold-opens.
- Areas of high security risk generally include where cash, narcotics, or retail operations are planned, as well as areas housing behavioral health (i.e. Psychiatry), Infant/Pediatric, Emergency Department, TBI (Traumatic Brain Injury) or ICU patients. These areas require greater access control, panic alarms and camera coverage. In some cases, specialized systems, such as Infant/Patient tracking and monitoring systems need to be incorporated into the design to include emergency card reader override buttons and one button lockdown feature as required.

- IDF closets require Lenel security systems and IP camera installed within. Access will be controlled by the MCIT Department.
- Exterior
 - Lighting design must carefully consider appropriate light levels without compromising security.
 - Employ “passive” security design strategies such as avoiding dead-end spaces and blind corners, and areas that are isolated from foot traffic or out of sight.
 - Consider relationship of ground floor spaces to the exterior for sightlines and access to open windows and doors.
 - Where security officer posts are required, consider issues of congestion, sightlines, ADA compliance and the physical comfort (furniture and HVAC) of the personnel.

4. *Related Security Design Guidelines*

- NYPD has published security guidelines entitled Engineering Security, Protective Design for High Risk Buildings. Where applicable these guidelines are to be referenced and utilized as necessary.

MISCELLANEOUS

This subsection is a running list of miscellaneous items that the A/E Team should consider during the Design and Construction process.

1. Firestopping

- Only Hilti products installed as UL-approved systems are permitted (unless otherwise allowed in the Design Guidelines).
- All firestopping must be performed by certified tradespersons qualified to use Hilti products.
- The A/E Team and RED+F Project Manager shall require the GC / CM to retain a certified independent firestopping firm to perform all firestopping work. Making individual trades responsible for firestopping their own penetrations is NOT acceptable.
- Please note firestopping requires a Special Inspection required by the NYC DOB and NYU Langone Facility Operations.

2. New Fire Extinguishers, Cabinets and Signs

- New fire extinguishers, recessed wall cabinets, and signs shall be purchased and installed as part of the capital project.
- Fire extinguishers shall be of appropriate type and size specified in quantities that provide sufficient coverage. The NYU Langone standard is a 10 lb. ABC fire extinguisher (dry chemical). It shall be used throughout except as noted below:

Area		Type	Size
Laboratory		ABC (dry chemical)	10 lb.
		D if flammable metals are present	Consult EH&S
Procedural Areas		CO ₂ (BC) within room	5 lb.
		Varies at Clean Corridors	Consult EH&S
MRI Suite	MRI Zone IV	MR-Safe (non-ferrous): CO ₂ (BC)	5 lb.
	MRI Zone III	MR-Conditional (non-ferrous): CO ₂ (BC)	5 lb.
	MRI Zone II	MR-Conditional (non-ferrous): ABC (dry chemical)	10 lb.
	MRI Zone I	ABC (dry chemical)	10 lb.
Food Preparation Areas (where frying/open flame occurs)		ABC (dry chemical)	10 lb.
		K (wet chemical) – 1 per 4 deep fryers K (wet chemical) – 1 per solid-fuel cooking device w/ fire boxes ≤ 5 cu.ft.	1.6 gal. (6L) (min.)
Mechanical Equipment Room (MER)		ABC (dry chemical) or CO ₂ (BC)	10 lb. (min.)
Generator Room		CO ₂ (BC)	5 lb. (min.)
Electrical Equipment Room (EER)		CO ₂ (BC)	5 lb. (min.)
Elevator Machine Room (EMR)		ABC (dry chemical)	10 lb. (min.)

- Front-of-house locations shall have recessed ADA-compliant fire extinguisher cabinets.
- Back-of-house locations shall have recessed fire extinguisher cabinets, unless it is not feasible.
- Do not install fire extinguishers or cabinets above power/data outlets, eye wash stations, safety showers, or behind door swings.
- The A/E Team and RED+F PM shall coordinate signage fabrication and installation with NYU Langone Design Studio’s Signage/Wayfinding Group.
 - Fire extinguishers and fire extinguisher cabinets must be identified by 3D signs.
 - Fire extinguisher cabinets with a solid door and no viewing panel shall have “Fire Extinguisher” message applied to the door. Such signage shall be NYULH-approved signage in front-of-house, patient-facing areas. NYULH-approved signage may also be requested in back-of-house areas but factory text shall also be permitted. If used, factory text shall be in red type and in the vertical orientation.
 - K-extinguishers shall have a flat mounted warning sign located above the extinguisher in English and Spanish stating “Warning in case of appliance fire, use this extinguisher only after fixed suppression system has been activated”.
 - Whenever provided within a fire hose cabinet, the fire hose and the extinguisher need to be called out with proper signage.
- Whenever provided within a fire hose cabinet, the window shall have both the fire hose and extinguisher visible from the outside.
- Contact Environmental Health & Safety (EH&S) for additional guidance.

3. *Egress Corridor Width Reduction and Storage Cabinet Placement*

- In new buildings and existing buildings to undergo renovation, the A/E Team shall endeavor to incorporate all storage within rooms. Storage within labs shall comply with the applicable building and fire codes and NFPA 45 (2015 edition).
- Requests to reduce the width of, and/or establish storage in, an egress corridor shall be assessed by a design professional in accordance with the applicable building code (including an occupant load calculation to determine required corridor width) and the latest version of the fire code, reviewed by EH&S and approved by RED+F leadership.
- Where corridor width reduction and storage is permitted by applicable codes and approved by RED+F leadership, the cabinets specified shall be non-combustible (metal), any viewing panels shall be glass, and the end user shall be informed that storage of flammable/combustible liquids and materials (e.g. chemicals, wood, cardboard, plastic, etc.) is prohibited. Appropriate signage shall be provided in coordination with NYU Langone Design Studio’s Signage/Wayfinding Group.

4. *Temporary Interior Construction Partitions*

- All NYU Langone interior construction projects, which are not confined to an enclosed room or space (i.e. corridor, etc.) and do not require a rated barrier, shall use the Edge Guard partition system.
- The A/E Team and RED+F Project Manager shall require the GC / CM to order this product in advance of start of construction as it may take several days for delivery.

5. *Ceiling Type Selection*

Existing infrastructure in some cases may prevent proper pressurization of specialized rooms. Selection of the appropriate ceiling type can mitigate these issues.

- For spaces requiring positive or negative pressure, the Architect shall meet with the RED+F Project Manager and Facilities Operations to determine the type of ceiling construction to be provided (i.e. acoustical ceiling tile or gypsum board ceiling with access panels).

6. *Refrigerator and Freezer Monitoring*

ELPRO is NYU Langone Health's standard, centralized temperature monitoring system for clinical and research refrigerators and freezers, and any moveable refrigeration equipment. It is not to be used for any other monitoring, such as room temperatures, pressures or humidity.

- For Clinical Facilities:
 - ELPRO is **required** for all Nourishment, Specimen, Medication (including vaccinations) and Breast Milk refrigerators and freezers.
 - For moveable equipment requiring temperature monitoring, such as reagent refrigerators and incubators, ELPRO can be installed at the clinician's request with approval from MCIT and RED+F Commissioning.
 - If your facility is an FHC, Community Medicine or School Health (Elementary/Middle School) site, notify RED+F Commissioning as additional monitoring and reporting may be required.
 - For the Vaccine for Children Sites only, the ELPRO CE Digital Data Logger shall be installed. In addition to the logger, an audible alarm must also be installed. The recommended model is the Health Care Logistics Memory Monitoring Refrigerator / Freezer Alarm, product number 10368.
- For Research Facilities:
 - ELPRO is **required** for all freezers housing research materials rated at -40°C or below, as well as for all Liquid Nitrogen tanks and cryogenic storage.
 - ELPRO can be installed in refrigerators and freezers of all temperatures, as well as incubators, at the research unit's request, with approval from MCIT and RED+F Commissioning.

- For ALL Applications:
 - ELPRO is **not** to be used for monitoring ambient room temperature, humidity or for monitoring pressure relationships. The Building Automation System (BMS or BAS) **must** be used for environmental monitoring. In areas where a BMS network may not be available, contact the RED+F Engineering and Commissioning group for direction.
 - All research -80°C through -140°C as well as liquid nitrogen dewar tanks and freezers shall be equipped with the ELPRO Central Monitoring System (CMS).

7. *Roofing and Waterproofing*

- All roofs and waterproofing shall be designed with a minimum 20 year warranty.
- Roof membranes, coatings and waterproofing products shall be cold apply, low VOC (less than 50 grams per liter) and low-odor emitting.
- 100% flood testing of roofs and waterproofing shall be specified. A bathtub flood testing method shall be used with water at least 2” deep for a minimum of 24 hours. If the area is large, it can be sectionalized to aid in construction, however, the sections shall overlap each other by a minimum of 5 feet or as agreed upon with NYULH.
- The use of torch down or other hot roof methods is prohibited unless specifically reviewed and approved by NYU Langone’s Facilities Management and EH&S.
- The following roof and waterproofing systems have been reviewed and used on NYU Langone projects:
 - Garland Green-lock
 - Kemper 2K PUR
 - Siplast Paraflex (Note: Siplast Parapro shall not be used unless reviewed and approved by Facilities Management and EH&S due to the respiratory and odor hazards it poses).
 - TQ3

8. *Pressurized Rooms*

- All areas listed in Table 7.1 of ASHRAE Standard 170 – Ventilation of Health Care Facilities that have a pressure relationship requirement need to have full height deck to deck walls (gypsum board finish the entire height from top of structural deck to underside of structural deck) with all penetrations sealed (inclusive of spaces with a hard gypsum ceiling).
- All conduits and back boxes leading out of the room shall be sealed with an approved product.

9. *Temperature Controlled Rooms (walk in box / cold room / environmental box):*

When designing these types of rooms, the following is required:

- Doors:
 - For any entry doors that are over 5 feet wide, a hydraulic door closer shall be installed.
 - Door heater wire to be installed on door frame as well as window of the door.

- Condensate drain inside unit needs to be insulated as well as properly pitched based on temperature control point. Vacuum breaks shall be installed on piping as required.
- Controller:
 - Cold room control panel requires UPS if connected to emergency power to prevent erroneous power trip resets.
 - Local controller high and low limits shall be calibrated and set at the same range as BMS low and high alarms (low-low, high-high.)
 - Digital temperature recorder needs to be installed in the room control panel.
- Power:
 - All receptacles inside the walk in box require insulation to protect from condensation due to temperature differences between the unit and the surrounding walls.
 - All conduit, wire and control device penetrations through the walk in box need to be sealed on both ends.
 - All power panels and outlets need to be properly labeled.
 - Evaporator fan(s) inside the room requires a local toggle on/off switch at each fan.
- Lighting:
 - Emergency light with moisture proof cover shall be installed in all cold rooms backed up by emergency power.
 - All light fixtures shall have a thermal seal.
- Condensing unit:
 - Shall have domestic water back-up connection (for the purpose of cooling tower shut down for maintenance or heat exchanger service for secondary chilled water.)
 - High and low pressure switches with manual resets shall be installed. Dual pressure switch safeties are not allowed.
 - Water cooled compressors shall have all trim installed on piping. This includes but not limited to pressure gauges, thermometers, balancing valves, strainer, etc.
 - Condenser access needs to be provided on the front and both sides. Top access (above room) is not acceptable.
 - An oil separator shall be installed if the refrigeration lines exceed length of 50 feet.
 - Vibration isolation shall be installed on condensing units.
 - If the refrigeration system has multiple circuits, the automatic switch over shall be shown on BMS graphics.
 - Alarms on BMS shall provide system fail, circuit fail and run time of each compressor.
 - Manual valves with service ports shall be installed on both sides of hot gas by-pass or suction electronic valve (depending on application)

- If there are plate and frame heat exchangers installed, pipe unions shall be installed on supply and return piping to allow for proper maintenance to punch tubes or clean plates.
- Password access to configuration page on local controller shall be provided to maintenance shop.

10. Security Control in Operational Technology Systems

- The A/E Team shall follow the latest version of NYU Langone Health’s *Guidelines for Security Control in Operational Technology Systems*.
- It shall apply to all NYULH projects where Operational Technology (OT) systems to monitor and control facility-related equipment and systems will be installed, upgraded or replaced.
- All OT system network designs shall be submitted to and reviewed by NYULH Information & Engineering Strategy for compliance with the guidelines and industry best practice standards.

DOS AND DON'TS

As part of our approach to continually improve the Design and Construction process, we at RED+F maintain a running list of Dos and Don'ts. This is a detailed list of items that we have found to work well (or not work well) for NYU Langone Health capital construction projects. We have listed these items in the following order:

- Architectural
- Interior Design
- Medical & Lab Equipment
- AV/IT & A/E Team Coordination

Architectural

1. Make sure patient room and patient toilet room saddles have no lip (not even code allowable 1/4"). Patients cannot negotiate with IV pole.
2. Make sure there are bed stops in Patient Rooms.
3. Where wall mounted soap dispensers are used, place them above countertops instead of above floors, so any drippings go on the counter.
4. Do not specify storage cabinets under sinks; use ADA-compliant panels instead. The area under sinks should be clear. It will fail DOH survey if storage is located underneath.
5. Provide the construction budget and schedule to the A/E Team before start of design. The A/E Team needs to design within budgetary and time constraints. They can't do that without a budget and schedule.
6. Obtain user equipment lists and determine infrastructure requirements (i.e. power requirements) ASAP so a test fit can be performed.
7. Floating ceilings might require sprinkler coverage ON TOP of them. Check it.
8. Be sure that room numbering adheres to NYU Langone standards. Device schedules need to match (for Fire Alarm Programming).
9. The Tisch Ancillary building is a balloon frame construction. There is no fire-stopping between the slab and curtain wall. Design drawings to address this. Millhauser is similar.
10. Do not 'float' HIPPA divider panels between desks. Sandwich the panels tight to the desks with no gaps for added stability and to prevent pens, papers, etc. from falling through.
11. Add card readers to all clean supply rooms.
12. Make sure mounting height of ADA mirrors is specified for the bottom of the *reflective surface* to be 40" AFF, not the mirror frame.
13. Camera locations need to be coordinated with the Security PM, Security vendor and the MCIT PM.
14. The Architect should do a file/storage survey during planning to make sure adequate file and storage space is factored into the design.

15. Provide electric locks for single doors and overhead electric strikes for glass doors. Avoid the use of maglocks whenever possible.
16. All interior finish and furniture drawings and specifications are to be uploaded to BuildFlow upon closeout.
17. MER doors to have Trilogy keypad locksets with T2 keyway. Must coordinate with NYU Langone locksmith.
18. Firestopping products shall not be used unless required for fire or smoke barriers. All firestopping must be performed by a certified tradespersons in firestopping, contracted under either the GC/CM. Making individual trades responsible for firestopping their own penetrations is not acceptable. They must use only Hilti products (unless otherwise allowed in the Design Guidelines), and must use UL-approved systems. A Special Inspection is required by NYC DOB and NYU Langone Facility Operations.
19. Cable trays are not to penetrate smoke or fire barriers. Cable trays are to stop at wall with cables traversing through EZ-Path devices, then resume with cable trays past penetration. Coordinate with MCIT PM.
20. Consideration must be given to additional data drop conduits and back boxes (with drag lines) to all rooms. Furniture layouts change, often times during construction, and the only drops in the room are behind furniture. This is especially the case with wall mounted computer work stations. Similarly, additional wall grounds are to be provided on a second wall in the event this location changes as well to avoid tearing open newly created walls.

Interior Design

1. Coordinate power/data drops with under-counter pedestal files, etc.
2. Make best efforts to marry up to a column / wall to reduce core drilling for power and data.
3. No visible whips are allowed when connecting to workstations.
4. Coordinate cable management with furniture (V30 training room - cables hanging from desktops and visible).
5. Purchase construction cores on wall / door systems, not pre-keyed cores. The main campus locksmith will provide final cores. For off-campus facilities, engage a locksmith.
6. Specify wardrobe closets in workstations and private offices whenever possible. Provide lockers elsewhere when this is not feasible.
7. Get signage requirements early to have permanent signage at opening. PM to provide the Signage / Wayfinding PM the project schedule.
8. Specify and install coat hooks in each toilet stall, single occupancy restroom, private office, exam room, changing room, lactation room, wellness room, etc.
9. Avoid specifying products that require overseas delivery unless stocked in the United States.

Medical / Lab Equipment

1. Do not provide UV lights as an option when ordering new Bio-Safety Cabinets for a lab or other type of project.
2. Do not specify direct-ducted bio-safety cabinets. Canopy connected A-2's with 70/30 air circulation are preferred. There are exceptions. Please review with EH&S before specifying.
3. Provide cabinets with side ports to allow tubing and wiring to be passed through the side as opposed to the front as a default. Review exceptions with EH&S before specifying.
4. Provide height adjustable biosafety cabinets as a default. Review exceptions with EH&S before specifying.

AV/IT & A/E Team Coordination

1. A/E Team shall fully coordinate with the IT consultant engaged directly with NYU Langone. Refer to the Information Technology subsection for further information.
2. IT Engineer infrastructure specification needs to be placed on the "E" drawings so that the electrical contractor can buy and install.
3. No MEP Services should pass through the IDF rooms that are not servicing the room.
4. Cable trays to be shown on all A/E drawings and coordinated appropriately with MCIT and the contractors. "Coordinate in field" is not acceptable.
5. Define who will buy the server UPS, Electrical or Low Voltage contractor PRE-BID.
6. Determine the power requirement at the rack early in the project.
7. Define AV equipment credenza ventilation requirements.
8. Coordinate light fixture locations to avoid racks / ladder racks. Wall mounted lights are acceptable.
9. Multiple outlets mounted above rack. Specifications should come from IT designer. Place the information on the Electrical plans for electrician to install.
10. Provide UPS to the rack. IT designer to specify the UPS. Electrical drawings shall show the UPS to be bought.
11. Each IDF room gets its own electrical panel. Power panels are to have surge suppressors.
12. Security panels typically go in IDF rooms. They require power and data connection. Coordinate requirements with the MCIT PM.
13. Cable Trays are to be designed by the IT designer, shown on the Electrical drawings and bought by the electrical contractor. It is critical that the cable tray path is coordinated with the MEP systems.
14. Coordinate pathway for conduits to building main IT rooms (BMS). Architects should include some allowance for demolition, temporary protection, patching, firestopping, etc. in the architectural plans.



2. EMERGING

Instructions to Engineer for preparing a design and specification:

- I. It shall be the Engineer's responsibility to follow these NYU Langone Health guidelines on all projects located on the main campus. For projects that are located off-campus, the Engineer shall follow these guidelines in conjunction with the building landlord's requirements.
- II. The information listed below is a guideline only. It shall be the Engineer's responsibility to conform to all appropriate building code requirements.
- III. All projects shall be designed in accordance with the applicable New York City Building Code, Mechanical Code, Fuel Gas Code, Fire Code, Energy Conservation Code, and the applicable standards referenced by these codes.
- IV. These Guidelines will be updated periodically and suggestions for updates may be made to the NYU Langone Project Manager. Requests and proposals for changes to the guidelines should be made in writing to a NYU Langone Project Manager assigned to the project who will forward such requests to RED+F Facilities Operations, as appropriate for review. RED+F Facilities Operations will advise the PM and Engineer in writing whether an exception to the Guidelines will be permitted or not.

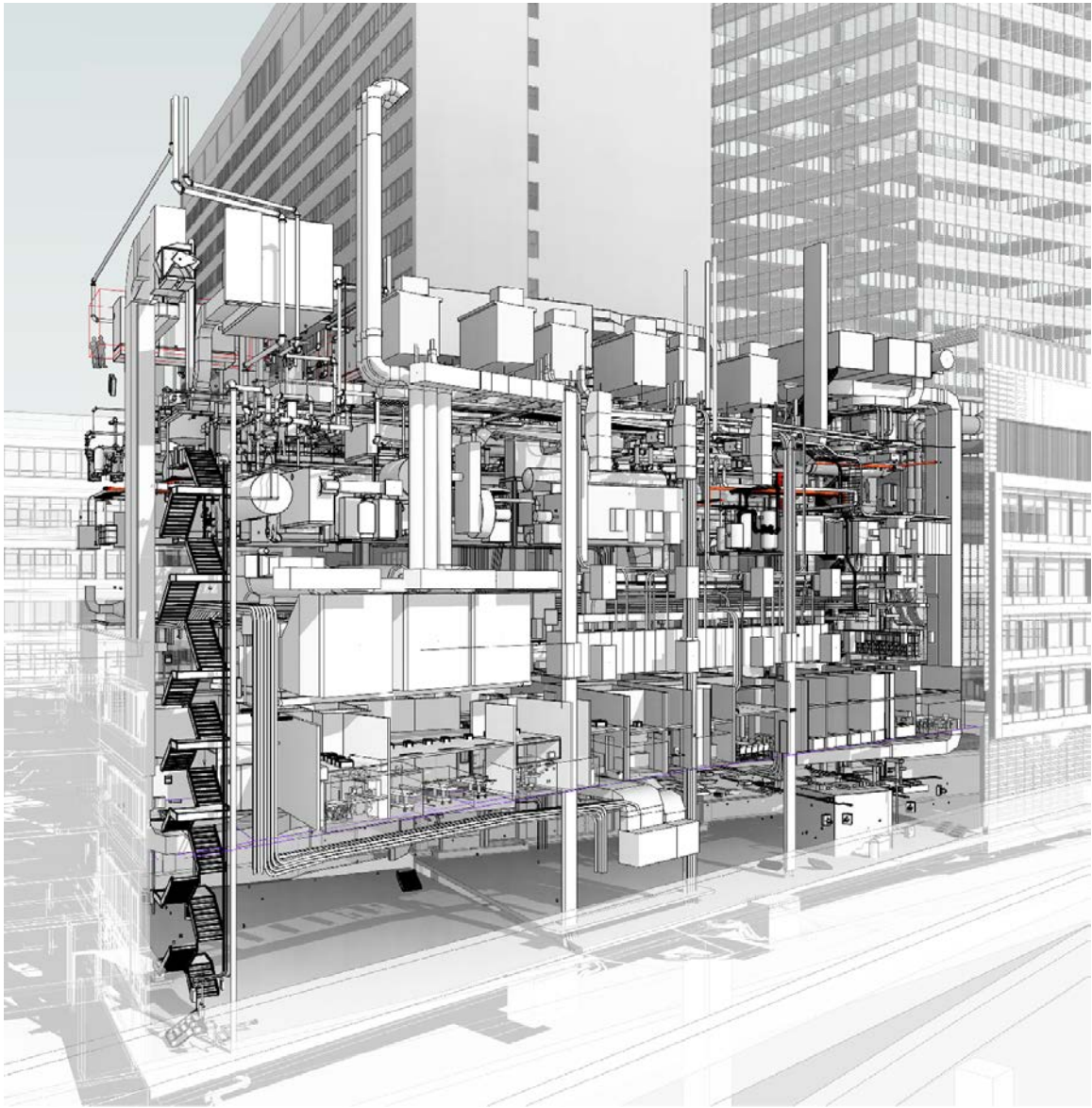

BIM Model of Energy Building – Ennead Architects

TABLE OF CONTENTS

1. GENERAL 358

- A. End of Project Requirements 358
- B. Training 359
- C. Mercury Elimination Program Compliance 359
- D. Equipment Manufacturers 359
- E. Equipment Access 359
- F. State, Federal & Utility Incentives..... 359
- G. Local Law 97 Compliance & Planning **(UPDATED)** 360
- H. Engineering Dos and Don'ts **(UPDATED)**..... 360

2. MECHANICAL 363

- A. Codes, Regulations and Design Standards 363
- B. Design Criteria **(UPDATED)**..... 363
- C. Mechanical Naming Convention 367
- D. Various **(UPDATED)** 368
- E. Pandemic Upgrades 370
- F. Equipment..... 370
 - 1. Access Doors 370
 - 2. Air Compressors 371
 - 3. Air Curtains..... 371
 - 4. Air Filters 371
 - 5. Air Handling/Conditioning Units **(UPDATED)** 371
 - 6. Air Outlets **(UPDATED)**..... 374
 - 7. Air Volume Regulators 375
 - 8. Baseboard Radiation (Steam/Water) 375
 - 9. Boilers 375
 - 10. Clean Steam Generators 375
 - 11. Chilled Beams (active) **(NEW)** 376
 - 12. Chillers **(UPDATED)** 376
 - 13. Condensate Pumps **(UPDATED)** 377
 - 14. Cooling/Heating Coils **(UPDATED)** 378
 - 15. Cooling Towers **(UPDATED)** 379
 - 16. Controllers (Water Level) 380
 - 17. Dampers (ALD's)..... 380
 - 18. Dampers (Dynamic Fire/Smoke) **(UPDATED)**..... 380
 - 19. Expansion Compensation..... 381
 - 20. Expansion Tanks 381
 - 21. Fans **(UPDATED)**..... 382
 - 22. Fan-Powered Boxes..... 382
 - 23. Fan Coil Units **(UPDATED)**..... 382
 - 24. Firestopping Products 383
 - 25. Flow Measuring Devices 383
 - 26. Fuel Oil Pumping Systems 384
 - 27. Fuel Oil Specialties 384
 - 28. Fuel Oil Tanks 384
 - 29. Fuel Oil Tank Gauging and Leak Detection Systems 385
 - 30. Freezestats 385
 - 31. Hangers, Anchors and Guides 385
 - 32. Heat Exchangers..... 385

33. Heat Trace	385
34. Humidifiers.....	385
35. Insulation (Duct and Pipe).....	386
36. Insulation Adhesives	387
37. Insulation Pipe Shields	387
38. Meters and Gauges	387
39. Motors (UPDATED)	388
40. Motor Starters.....	389
41. Motor Control Centers.....	389
42. Motor Controllers Variable Speed (VFD) (UPDATED)	389
43. Orifice Steam Traps (Venturi Orifice Type)	390
44. Pipe and Fittings.....	390
45. Pressure-Regulating Valves/Stations	391
46. Pumps	391
47. Radiant Heating Systems	392
48. Refrigerant Monitoring Systems	392
49. Sound Traps	392
50. Steam Traps – See also Orifice steam traps	392
51. Steam Piping	393
52. Strainers	393
53. System Identification (UPDATED)	394
54. Temperature Controlled Rooms (walk in box / cold room / environmental box) (NEW)	396
55. Unit Heaters.....	396
56. Valves (UPDATED)	396
57. Variable Air Volume (UPDATED)	399
58. Variable Frequency Drives	399
59. Variable Refrigerant Flow System (VRF) (UPDATED)	400
60. Vibration Isolators.....	401
61. Water Filtration.....	401
62. Waterproof Sleeves	402
63. Water Source Heat Pumps.....	402
64. Water Treatment/Cleaning.....	402
G. Cost-saving Alternatives (UPDATED)	404
3. ELECTRICAL	405
A. Codes, Regulations and Design Standards	405
B. Design Criteria	405
C. Electrical Naming Convention	407
D. Various (UPDATED)	411
E. Equipment.....	412
1. Automatic Transfer Switches	412
2. Busway and Accessories.....	412
3. Cable Pulling Lubricants	412
4. Cable Tray and Fittings.....	413
5. Clocks	413
6. Dry-type Transformers.....	413
7. Electric Heating Cable Systems	413
8. Electrical Conductors, Copper, 600 Volt or Less	414
9. Electrical Metallic Tubing (EMT)	414
10. Electronic Fluorescent Ballasts	414
11. Electronic Fluorescent Dimming Ballasts	414
12. Electronic Dimming System	414

13. Enclosed Switches	414
14. Exit Signs (UPDATED)	415
15. Fire Detection, Alarm and Communication.....	415
16. Flexible Metal Conduit	415
17. Flexible Metal Conduit Fittings	415
18. Fluorescent Lamps	415
19. Fuses	415
20. Generator (UPDATED)	416
21. Heat Trace	416
22. High Intensity Discharge Lamps	416
23. LED Light Fixtures.....	416
24. Lighting.....	416
25. Lighting Controls (UPDATED)	417
26. Line Voltage Switches, Wall Plates, and Coverplates.....	417
27. Liquid-tight Flexible Metal Conduit.....	418
28. Liquid-tight Flexible Metal Conduit Fittings	418
29. Motor Control Centers	418
30. Motor Controllers Variable Speed (VFD)	418
31. Multi-outlet Assemblies	418
32. Outlets and Boxes	418
33. Overcurrent Protective Devices	419
34. Panelboard	419
35. Receptacles (UPDATED)	419
36. Rigid Aluminum Conduit and Fittings.....	420
37. Rigid Nonmetallic Electrical Conduit and Fittings	420
38. Rigid Steel Conduit and Fittings (exposed to the weather) (UPDATED)	420
39. Rigid Steel and Intermediate Metal Conduit.....	420
40. Rigid Steel and Intermediate Metal Conduit Fittings.....	421
41. Service Switch Assemblies and Distribution Switchboards.....	421
42. Submetering and Power Quality Metering	421
43. System Identification	421
44. Transient Voltage Surge Suppression	422
45. Type "AC" (Armored Cable) Conductor Cables, 600 Volts or Less	422
46. Vibration Isolation Devices and Seismic Restraints	422
47. Wall Dimmers.....	422
48. Wire Connectors and Lugs	423
49. UPS (Central) (UPDATED)	423
50. UPS (Rack Mounted)	423
F. Cost-saving Alternatives.....	424
4. PLUMBING	425
A. Codes, Regulations and Design Standards.	425
B. Design Criteria (UPDATED)	425
C. Equipment.....	426
1. Acid Neutralization.....	426
2. Backflow Preventers	427
3. Baseboard Radiation (Steam/Water).....	427
4. Drains	427
5. Electric Water Coolers.....	427
6. Fixture Supports.....	427
7. Flow Measuring Devices (NEW)	427
8. Gauges and Thermometers.....	427

9.	Hot Water Heaters	428
10.	Insulation	428
11.	Medical Air Compressors	429
12.	Medical Gas Equipment	429
13.	Medical Gas Outlets	429
14.	Motors.....	429
15.	Motor Starters.....	430
16.	Motor Controllers Variable Speed (VFD)	430
17.	Orifice Steam Traps (Venturi Orifice Type)	430
18.	Pipe and Fittings (UPDATED)	430
19.	Pipe Hangers and Supports	431
20.	Pipe Joint Compound	431
21.	Plumbing Fixtures.....	431
22.	Purified Water System Equipment (Reverse Osmosis and Deionized Systems)	432
23.	Safety Showers/Eyewashes.....	432
24.	Seismic Restraints	432
25.	Sump Pumps and Ejectors.....	432
26.	System Identification (UPDATED)	432
27.	Toilet Seats.....	432
28.	Vacuum Pumps	432
29.	Valves	432
30.	Water Supply Pumps.....	434
D.	Cost-saving Alternatives (UPDATED)	434
5.	FIRE PROTECTION.....	435
A.	Codes, Regulations and Design Standards	435
B.	Design Criteria (UPDATED)	435
C.	Equipment.....	437
1.	Anchors and Inserts	437
2.	Motor Starters.....	437
3.	Motors.....	437
4.	Pipe Hangers and Supports	437
5.	Piping	437
6.	Preaction Control Panel/Equipment (UPDATED)	438
7.	Preaction/Dry Pipe Valves.....	438
8.	Pressure-Reducing Valves	438
9.	Pumps	438
10.	Standpipe System Equipment	439
11.	Seismic Restraints	439
12.	Sprinkler Heads, Valves, Alarms, Etc.	439
13.	System Identification	439
14.	Tamper Switches.....	440
15.	Valves	440
16.	Vibration Isolators.....	440
17.	Water Flow Switches.....	440
18.	Water Proof Sleeves.....	441
D.	Cost Saving Alternatives	441
6.	FIRE ALARM.....	442
A.	Codes, Regulations and Design Standards	442
B.	Design Criteria	442
C.	Equipment.....	442
1.	Fire Alarm System	442

2.	Heat Detectors	442
3.	Strobe/Speaker	443
4.	Strobe/Horn	443
5.	Strobe.....	443
6.	Smoke Detector	443
7.	Duct Detector.....	443
8.	Manual Pull Station.....	443
9.	Aspirating Smoke Detection Systems (NEW)	443
7.	BUILDING MANAGEMENT SYSTEM.....	444
A.	Codes, Regulations and Design Standards	444
B.	General Requirements and Policy (UPDATED)	444
C.	Locations (UPDATED)	448
D.	People	449
E.	Deliverables (UPDATED)	450
F.	Performance and Functional Requirements (UPDATED)	458
G.	Parts (UPDATED)	483
H.	Smarts (UPDATED)	511
I.	References (UPDATED)	535

1. **GENERAL**

A. **End of Project Requirements**

As part of a break-out cost, the design engineer shall review the as-built documentation provided by the subcontractors and edit the project design documents to reflect the “as-built” condition. The engineer shall confirm the collaborated as-builts are correct and complete. To create these collaborated as-builts the design engineers shall use the contractor as-builts as a reference, which shall be provided to the engineer in PDF form and native (AutoCAD or Revit).

I. Single Line Diagrams

- Steam Distribution
- CHW Distribution
- CW Distribution
- Domestic Water Distribution
- Sanitary and Storm Drainage Distribution
- Medical Gas Distribution
- Medical Vacuum Distribution
- Electrical Distribution (Normal and Emergency)
- Controls System

II. Floor plans

III. Life Safety Drawings which include the following but not limited to:

- Sprinklers
- Fire Standpipe
- Strobes
- Pull stations
- Smoke doors
- Magnets for doors
- Smoke compartments
- Egress paths
- Flow tamper switches
- Exit Signs
- Fire/smoke and smoke dampers

IV. Floor Plans indicating room pressure relationships

V. Campus Wide Equipment Schedules

All major MEP/FP/FA equipment removed and installed (in excel format).

B. Training

Training for new equipment or controls shall be written into design specifications. There shall be two training sessions, one in the morning and one in the afternoon to pick up all worker shifts. Training syllabus shall be provided to design engineer as well as NYU Langone Health RED+F Facilities Operations for review prior to training sessions for review and comment. Training must be done by qualified personnel with intricate knowledge of equipment and system and not by salesman.

C. Mercury Elimination Program Compliance

In an effort to protect patients, staff, researchers and the environment, it is the policy of NYU Langone Health to prohibit the use of mercury-containing equipment, materials and instrumentation where safe, effective alternatives exist. This program is outline in more detail in NYU Langone Health Safety Policy No. 170. Typical mercury-containing materials could include—thermostats, switches, float controls and lamps. Approved suppliers with known mercury-free alternatives are identified herein, but this list should not be assumed to be complete. If a designer or engineer believes the use of mercury-containing materials (besides UV, florescent and LED light bulbs, ballasts and mercury-containing batteries, which are exempted) is mandatory, the need must be formally presented to the NYU Langone Health RED+F Facilities Operations Department to obtain express permission for its use prior to any deviation from this guideline.

- I. If permission for use of mercury-containing materials (besides UV, florescent and LED light bulbs, ballasts and mercury-containing batteries) is given by RED+F Facilities Operations then engineers, designers or installers must ensure the proper inventorying, reporting and safe handling of any mercury-containing materials and equipment. These requirements include:
 - a. Labeling of Material - Proper “mercury-containing material” stick-on labels can be obtained from Facilities Operations (Greenberg Hall, SC2, Rm 122)
 - b. Inventorying of Material – An inventory log of properly labeled materials/equipment with installation date and specific location must be submitted to Facilities Operations by the end of project as part of closeout documentation.
 - c. Complying with all safe handling and disposal guidelines outlined by NYU Langone Health Environmental Health & Safety in its policies available on its website and referenced in contracts.

D. Equipment Manufacturers

U.S.-made is strongly preferred. Non US manufacturers will be considered. Example: Ventrol, Mammoth, Alliance Air, etc.

E. Equipment Access

All equipment shall be installed with manufacturer’s recommended clearance or code required clearance for maintenance and repair.

F. State, Federal & Utility Incentives

Financial rebates and incentives may be available for select mechanical, electrical, plumbing, and energy management projects. Project team shall inquire and review

eligible incentives with the energy & sustainability team. Rebates and incentives may be offered by, but not limited to, Consolidated Edison Company of New York, Long Island Power Authority, and New York State Energy Research and Development Authority (NYSERDA).

G. Local Law 97 Compliance & Planning

Projects within New York City must complete a life cycle cost review of Local Law 97 compliance and potential penalties based on project design. Any scenario planning around energy infrastructure must take into account amortized life cycle cost of future penalties using a moderate approach to carbon coefficients after 2034. This includes installations and upgrades to mechanical equipment that impact building energy use type and consumption, such as but not limited to: boilers, generators, chillers, and heat pumps.

H. Engineering Dos and Don'ts

1. If an item is not included in the guidelines, follow up with facilities.
2. Confirm with RED+F PM team that Commissioning has been bought out to a third party to include specs in engineering subsections. This is a code requirement for Article 28 spaces. In addition, commissioning is a DOB requirement for non-Article 28, please reference the NYC Energy Code for specifics.
3. Design engineer to confirm with RED+F PM that a page turn has been setup with facilities at different stages of design (schematic, design development, contract drawings).
4. Design Engineer or Architect to carry meeting minutes during page turn with facilities and submit to facilities after meeting.
5. If designing an Article 28 space, provide drawing notes for all trades to prevent any object from touching, laying or hanging from sprinkler piping.
6. Ensure BMS sequence operations lines up with control sensors indicated on one-line drawings.
7. Do not have all similar equipment on the same electrical panel. Distribute the electrical loads. (i.e. like pumps, AHUs, etc.)
8. If designing HVAC for sterilizers, heat load calculation shall be run for skin loss as well as cooling of cleaned items right after a sterilization cycle. Common engineering mistake is to not calculate for the heat load of sterilized items that are cooling in the space and sufficient cooling is never provided.
9. Enforce the completion of "as-builts" and turnover to NYU Facilities.
10. Obtain HVAC traverse readings and electrical tracing at the start of design process.
11. Do not discharge steam condensate pump vents into MER. Vents to discharge to the outdoors.
12. Steam condensate piping shall be pitched by gravity to condensate pump, No trapping or lifting of condensate via steam shall be allowed.
13. Provide filtration and chemical treatment on closed loop systems.

14. AHU control devices shall be located outside of the airstream. Do not mount inside unit.
15. All primary chilled water coils and valves in the Manhattan Main Campus shall be designed to 400 psi at an ANSI pressure class of 300lbs.
16. Outdoor ductwork shall be pitched on top to prevent water accumulation.
17. In the main campus, all automatic transfer switches shall be specified with a dead neutral position and delay transfer feature.
18. Sprinkler system shall have a means of draining, do not trap water in sprinkler piping.
19. In the main campus, do not send generated steam condensate from clean steam generators that serve air handler humidifiers back to Energy Building. Generated clean steam condensate shall be removed from campus via drains per DEP standards. Primary steam condensate from the Energy Building shall be pumped back to the plant.
20. Do not substitute Terminal Reheat Units for Induction Units and vice versa without a Facilities Operations engineering review.
21. Provide power for Lighting Circuits from lighting panels. Receptacles and convenience outlets shall be provided power from utility panels and receptacle panels.
22. NYU Langone's main campus does not provide natural gas to lab benches. Do not design for this service, and include removal of same on the demolition plans.
23. Define that power tie in's to furniture are to be performed by the electrical contractor. Engineer to include on the "E" drawings. PM to confirm with the GC/CM.
24. Do not locate IT room HVAC equipment in ceilings of the rooms. Locate outside the rooms and duct in. Or use a split system and hang the evaporator on the wall and drain outside the room.
25. Use only concealed sprinkler heads, not recessed.
26. Specify tamperproof receptacles in all waiting rooms, regardless of the clinical function of the practice.
27. For laboratory equipment rooms, provide exhaust registers directly above heat generating equipment.
28. Include UL-approved pass-thru sleeves for future use in all smoke/fire partitions to prevent non-firestopped penetrations resulting from future cable pulls.
29. Thought must be given to redundancy for critical MEP systems. If a system loss will result in compromised patient safety or revenue loss to the institution, redundant systems need to be included in the design (i.e. emergency power, UPS, etc.)
30. DO NOT USE **USG Sheetrock Acoustical Sealant** at medical gas copper pipe penetrations. It corrodes the pipes. Use an alternate.
31. Include Hands-on Training for maintenance staff for all MEP equipment. In the main campus, two training sessions shall be provided, one early in the morning and one at night. For off-site locations, contact RED+F for amount of sessions.

32. Indicate on drawings where high point vents shall be required on pipework.
33. For phased projects that may have multiple contractors of the same trade, ensure that submitted equipment and components remain consistent throughout the project (i.e. same manufacturer, same model, etc.).
34. If existing services are to remain in a renovated space, those existing services are to be brought up to NYU Langone current standards.
35. Piping taps for pressure sensing devices shall be top tap only. Side or bottom taps are not allowed.
36. Medical gas takeoffs from riser shall be full size throughout floor loop. The piping size shall not be reduced on a floor loop. Takeoffs from floor loops shall be sized adequately.
37. Vacuum risers shall be full size. Do not reduce size at end of riser.
38. Pipe sleeves shall be provided for all piping wall penetrations
39. Mechanical piping shall be secured down with brackets or provided with saddles under the insulation
40. Provide means of hoisting equipment from floor to working level if maintainable equipment is above 6 feet above finished floor. Means of hoisting can include trolley I-beams, eye hooks, winches, etc.
41. Balancing valves shall not be used as shutoff valves. Provide dedicated shutoff valve for system/equipment isolation.
42. Low voltage cable located in mechanical, electrical or equipment rooms shall be in conduit. Free air is not allowed.
43. Rooftop equipment that has access doors/areas that are above 3 feet above final roof line shall have dunnage installed around the entire unit.
44. Any rooftop equipment that is within 6 feet of the edge of a roof that has no parapet wall shall have guardrails.
45. All rooftop equipment shall have proper lighting, service outlets and hose bibs (with roof drains) for cleaning purposes.

END OF GENERAL SUBSECTION

2. MECHANICAL

A. Codes, Regulations and Design Standards

Comply with all current New York City Building Codes, Joint Commission Standards, National Institutes of Health and all authorities having jurisdiction and applicable national, state and local codes, laws and regulations governing or relating to any portion of this work.

Laboratory and Hospital environmental conditions, air filtration, air change rates and pressurization relationships will be in accordance with the requirements set forth in American Society of Heating, Refrigerating, and Air Conditioning Engineers (ASHRAE), American Institute of Architects (AIA), National Institute for Occupational Safety and Health (NIOSH), National Fire Protection Association (NFPA), Centers of Disease Control and Prevention (CDC), and all other applicable governmental Codes.

If any design standard within this document contradicts codes or regulations, the design engineer shall notify NYU Langone Health.

B. Design Criteria

I. Chilled Water

- a. General Chilled Water Supply and Return Temperatures: 45°F/57°F
 - i. Manhattan Main campus primary chilled water shall be designed with a 48°F entering chilled water temperature
- b. Operating Room Chilled Water Supply and Return Temperatures: Contact Facilities Operations for proper values.
- c. If Chilled Water will be decoupled from main campus, Chilled Water system with a heat exchanger, higher design temperatures shall be used and approved by Facilities Operations
- d. 2-way control valves shall be used

II. Condenser Water (campus)

- a. Condenser Water Supply Temperature: 85°F
- b. Condenser Water Return Temperature: 95°F
- c. 2-way control valves shall be used

III. Condenser Water (process)

- a. Condenser Water Supply Temperature: 80°F
- b. Condenser Water Return Temperature: 90°F

IV. Steam

- a. Working pressure of steam is
 - 1) LPS – 5 psi
 - 2) MPS – 25-80 psi
 - 3) HPS – operating: 150-180 psi, maximum: 200 psi
 - 4) HHPS – 600 psi

- b. Clean steam generation shall be used for humidification and for direct injection sterilization.

V. Perimeter Heating

- a. Non potable hot water shall be designed to an Outside Air Temperature reset control scheme.

VI. Outside Design Conditions

- a. The mechanical systems shall be selected to serve a facility as specified within the New York City Building Code.

VII. Internal Design Conditions

- a. Offices, Conference Rooms, Classrooms, Student Areas and Similar Areas
 - 1) Occupied:
 - a) Heating: 68-74°F D.B.
 - b) Cooling: 68-75°F D.B. with a maximum of 60% R.H.
 - c) Conference rooms, libraries, study halls and similar spaces shall have CO2 monitoring and demand ventilation control.
 - 2) Unoccupied Setback:
 - a) Heating: 65°F D.B.
 - b) Cooling: 85°F D.B.
 - c) Airflow Setback (non-critical only): 15-20% of design. Control shall be on a room-by-room basis with a local over-ride at the respective temperature sensor.
- b. Laboratories, Lab Support Areas and Similar Areas
 - 1) Occupied:
 - a) Heating: 68°F D.B. with a minimum of 35% R.H ±5%
 - b) Cooling: 75°F D.B. with a maximum of 50% R.H.
 - c) Air Change Rate shall be determined based upon minimum code requirement or cooling load, whichever is greater. In no instance shall it be less than 6 air changes per hour unless an air sampling system is being used. Demand control ventilation is allowed on a case by case basis which shall be reviewed with Facilities Operations.
 - 2) Unoccupied Setback:
 - a) Heating: 65°F D.B.
 - b) Cooling: 85°F D.B.
 - c) Airflow Setback (non-critical only): pressurization shall be maintained with reduced airflow. Methodology shall be reviewed with facilities operation prior to design.
 - d) Air Change rate shall be determined based upon minimum code requirement or cooling load, whichever is greater. In no instances shall it be less than 6 air changes per hour unless an air sampling system is being used. Demand control ventilation is allowed on a case by case basis which shall be reviewed with Facilities Operations.

- c. Health Care Facility Areas
 - 1) Operating Rooms: 68-78°F D.B. depending on function of Operating Room. Temperature shall be discussed with Facilities Operations and with end user. Minimum of 30% R.H. and maximum of 60% R.H.
 - a) The ventilation systems shall be capable of flow tracking for the supply, exhaust, and return on a room by room basis.
 - b) Sequence of operations shall be coordinated with requirements in the Building Management System design guidelines.
 - 2) All other Health Care Facility Areas shall be designed to the data listed within the latest edition of the FGI Guidelines and ASHRAE 170 – Ventilation for Health Care Facilities.
 - 3) Procedure Rooms/Isolation Rooms/Protected Environment Rooms
 - a) The ventilation systems shall be capable of flow tracking for the supply, exhaust, and return on a room by room basis.
 - b) Temperature shall be discussed with Facilities Operations and with end user
 - c) Sequence of operations shall be coordinated with requirements in the Building Management System design guidelines.
- d. Vivarium and Support Areas

The data within this subsection shall be superseded by the most current version of NIH Guidelines. All temperature conditions shall be reviewed with NYU Langone Health DLAR and Facilities Operations. The final design shall be confirmed by all parties.

 - 1) Unoccupied Setback:
 - a) Areas with animal habitats shall not be allowed a temperature or airflow setback.
 - b) Any rooms that are designed with an unoccupied schedule shall be confirmed with NYU Langone Health DLAR and Facilities Operations.
- e. Electrical Closets
 - 1) Ventilated to 80°F D.B. average, 85°F D.B. maximum.
- f. Switchgear Rooms
 - 1) Air Conditioned to 78°F D.B. The design shall be an N+1 configuration.
- g. Communication Closets
 - 1) Heating: 65°F D.B. minimum (if room is on perimeter of building)
Cooling: 78°F D.B. average, 83°F D.B. maximum.
- h. Storage/mechanical areas:
 - 1) Ventilated
- i. Elevator machine rooms:
 - 1) Air conditioned to 78°F dry bulb minimum.

- j. Sterilizers:
Calculation for heat gain from a sterilizer shall be the skin loss of the sterilizer plus cooling load required during cooling of cleaned/sterilized items. Engineers shall note on a design drawing what the skin loss of the sterilizer is as well as what the cooling load for sterilized/cleaned items is.
- k. Toilets: Ventilate to New York City Mechanical Code requirement.

VIII. Internal Load Criteria

Refer to ASHRAE Handbook – Fundamentals; Nonresidential Cooling and Heating Load Calculations Chapter and ASHRAE Handbook – Applications; Laboratories Chapter and Health Care Facilities Chapter.

IX. Lighting and Equipment Heat Gains

- a. Base design on data listed within ASHRAE Handbook – Fundamentals; Nonresidential Cooling and Heating Load Calculations Chapter and ASHRAE Handbook – Applications; Laboratories Chapter and Health Care Facilities Chapter.

X. Hours of Operation

- a. Offices: 12hrs/day, 5 days/week
- b. Laboratories/Support Areas: case by case basis to be discussed with end user.
- c. Health Care Facility/Support Areas: 24 hrs/day, 7 days/week
- d. Vivarium: 24 hrs/day, 7 days/week

C. Mechanical Naming Convention

I. Equipment Naming Scheme

Example: AHU-TH-1-2

<u>AHU</u> <u>Unit Type</u>	-	<u>TH</u> <u>Building Name (Location of Unit)</u>	-	<u>1</u> <u>Floor #</u>	-	<u>2</u> <u>Unit #</u>
AC – Air Conditioning Unit (cooling only)		ALH – Alumni Hall				
ACB – Active Chilled Beams		BRK – Brooklyn Lutheran				
ACC – Air Cooled Condenser		BRG – Berg				
ACCH – Air Cooled Chiller		EB – Energy Building				
AF – Air Filter		GBH – Greenberg Hall				
AHU – Air Handling Unit		HCC – Health Care Center				
B – Boiler		KP – Kimmel Pavilion				
CAV – Constant Air Volume Unit		MSB – Medical Science Building				
CH – Chiller		SB – Science Building				
CP – Condensate Pump		SKB – Skirball				
CSG – Clean Steam Generator		SRC – Smilow Research Center				
CT – Cooling Tower		TH – Tisch Hospital				
CWP – Condenser Water Pump						
ET – Expansion Tank		For all offsite locations, confirm				
EX – Exhaust Fan		Building name with RED+F				
FCU – Fan Coil Unit		Space Planning division.				
FOP – Fuel Oil Pump						
GX – General Exhaust Fan						
HWP – Hot Water Pump						
KEF – Kitchen Exhaust Fan						
PCHP – Primary CHW Pump						
PFHX – Plate and Frame Heat Exchanger						
PRV – Pressure Reducing Station						
RAF – Return Fan						
SAF – Supply Fan						
SCHP – Secondary CHW Pump						
STHX – Shell and Tube Heat Exchanger						
SX – Smoke Exhaust Fan						
TX – Toilet Exhaust Fan						
UH – Unit Heater						
VAVS – Variable Air Volume Supply Box						
VAVR – Variable Air Volume Return Box						
VAVX – Variable Air Volume Exhaust Box						
VFD – Variable Frequency Drive						
WSHP – Water Source Heat Pump						

*NOTE: for renovation projects the engineer shall inquire what the existing labelling scheme is on the floor and continue with the last number using the labeling scheme above. Example: if the floor has VAV’s on the 2nd floor of MSB labelled as VAV-1 through VAV-11, engineer shall start new labeling as VAVS-MSB-2-12

- II. FSD/FD labeling scheme:
Example: HCC-1-FD-2

<u>HCC</u> See building labeling scheme in previous table	-	<u>1</u> Floor #	-	<u>FD</u> FD – Fire Damper FSD – Fire Smoke Damper SD – Smoke Damper	-	<u>2</u> FSD #
--	---	--------------------------	---	--	---	------------------------

D. Various

I. Testing and Balancing –

- a. Aeroseal shall not be used to seal new ductwork. Aeroseal may be used only in existing inaccessible exhaust risers with proven air leakage. The use of Aeroseal on any other type of ductwork shall not be used unless discussed and approved by NYULH Facilities.
- b. All projects shall have a TAB baseline taken of space prior to design/demo to confirm existing conditions.
- c. All Testing and Balancing values shall be within -5% / +10% of design values on a per outlet basis.

d. Duct Leakage Testing Standards:

Duct Class	Pressure	Seal Class	Leakage Class
Medium Pressure Horizontal	3” – 6”	A	4
Medium Pressure Risers	3” – 6”	A	4
Low Pressure	2” and below	A	6

*Note: Low Pressure testing only applicable to sections greater than 100 square feet of duct surface area.

- e. All hydronic piping shall be hydrostatically tested to 1.5 working pressure but not less than 100psi for a minimum of 2 hours. Temperature readings of the piping being tested shall be taken prior to the test and at the conclusion of the test. All tests to be witnessed by owner.

f. All refrigerant piping shall be tested per the following:

Pressure Testing for leaks

- Charge system with regulated dry nitrogen and the appropriate tracer gas to pressure defined by engineer of record (EOR) or Manufacturer.
- Branches may be tested in segments to reduce the time needed to locate leaks. However, for the final test, entire system must be tested as one.
- When all leaks have been repaired and sections have been retested, the system must stand, unaltered, for 24 hours with no more than a +/- 1 pound pressure change.

- If system does not drop below specified pressure within 24 hours, the system is then ready to be evacuated.

Evacuation Procedure

- Pull a system vacuum down to at least 1000 microns (+/- 50 microns) and close the vacuum header valves. If the system cannot pull a vacuum at any step and returns to atmospheric pressure, which is an indication of a leak, test for and repair the leak using the previously described procedure with tracer gas.
 - If the 1000 micron vacuum holds for 30 minutes (+/- 50 microns), break the vacuum with dry nitrogen to a pressure of 2 psig
 - Install system suction and liquid drier cores.
 - Pull a second vacuum to a minimum of 500 microns.
 - Close vacuum header valves.
 - If the 500 micron vacuum holds for a minimum of 30 minutes (+/- 50 microns), then break the vacuum with the refrigerant to be used in the system to a pressure of 2 psig.
 - Pull a third vacuum to a minimum of 300 microns (+/- 50 microns).
 - Close vacuum header valves and allow system to stand for a minimum of 24 hours
- g. All pressure sensitive rooms shall have pressure relationship between room and outside space shown on report.
 - h. Pressure sensitive rooms shall be tested prior to ceiling being installed to confirm design pressure relationships between pressurized room and adjacent spaces.
 - i. Article 28 space balancing reports shall show pressure in and pressure out per FGI Guidelines.
 - j. Balancing reports for any rooms designed to be positive or negative pressure must include the room's pressure on the report. Report cannot be approved unless $-.01''\text{wc}/.01''\text{wc}$ is obtained while also meeting design flow CFM +/-10%.
 - k. Testing and Balancing contractors shall be NEBB, TABB or AABC certified. Non-certified TAB contractors are not allowed.
- II. All equipment shall be cleaned prior to starting/turnover.
 - III. Hydronic systems with bottom of system make-ups must have a manual make-up connection RPZ/backflow preventer at the top of the system as a backup
 - IV. Heat Recovery systems shall be enthalpy wheels, hydronic glycol based systems or air to air heat exchangers. These shall be designed on a case by case basis and will need to be reviewed and approved by Facilities Operations.
 - V. Pressure dependent rooms shall always have a schedule shown on drawings indicating location, room name, room use and pressures required to meet code criteria. Testing and Balancing reports for these rooms shall always indicate design pressure and actual pressure of room.

VI. Factory Witness Tests –

- a. The following equipment shall be factory witness tested. See individual equipment subsections for further information regarding required tests. Maximum of two people (not including manufacturer). FWT shall include lodging, meals and travel for two NYULH personnel.
 - 1) Air Handling Units
 - 2) Chillers
 - 3) Boilers

VII. Field Testing

- a. The following equipment shall be field witness tested. See individual equipment subsections for further information regarding required tests.
 - 1) Field Assembled Air Handling Units

VIII. Flexible ductwork is not allowed in healthcare projects.

IX. Slip and Drive connections for ductwork are only permitted when space in ceiling is limited.

X. Provide futures when tapping off piping risers.

XI. Brass caps shall be provided on all drain lines.

XII. Follow/refer to the “Dos and Don’ts” section for additional Engineering guidelines.

E. Pandemic Upgrades

- I. All upgrades shall be discussed with Facilities Management. The HVAC systems shall have the following upgrades:
 - a. Minimum MERV 13 filters
 - i. For clinical areas: Ability to add HEPA filtration when needed
 - b. Ability to operate spaces at a humidity level of 40% when needed
 - c. Ability to operate with 100% OA when needed with OA intake of unit minimum 50 feet from the exhaust of any system and street level
 - i. Base design to be return air (or enthalpy recovery)

F. Equipment

1. Access Doors

Access doors shall be provided in any spaces where maintenance of any system (air or water) will need to be provided. A minimum size of 24x24 shall be provided, if smaller size is requested, obtain permission from Facilities Operations. Access shall be provided to all piping trim, dampers, actuators, shut off valves, BMS Sensors, equipment both sides of reheat preheat and cooling coils and any other equipment required maintenance access. The doors shall not be blocked by piping, electrical conduit, ceiling support iron or hangers.

Approved Manufacturers:

a. Finished Construction:

- 1) Karp
- 2) Mil-Cor
- 3) Ruskin

b. Sheetmetal (doors):

- 1) Duct Mate
- 2) Flexmaster
- 3) Ruskin

c. Sheetmetal (hardware):

- 1) Arlan
- 2) Duro Dyne
- 3) Ventlok

2. Air Compressors

Medical air compressors – see plumbing design guidelines.

Approved Manufacturers:

- a. Sullair
- b. Quincy
- c. Ingersoll Rand

3. Air Curtains

Air curtains shall be provided with a door switch to operate only when doors are open.

Approved Manufacturers:

- a. Berner International Corp.
- b. King
- c. Mars Air Door
- d. Powered Aire Inc.

4. Air Filters

Approved Manufacturers:

- a. Viledon
- b. Flanders
- c. Fiber Bond

5. Air Handling/Conditioning Units

If installing equipment on a roof, refer to Do's and Don'ts section for requirements.

Units shall be furnished with unit controls to comply with the requirements of the most current New York City Energy Conservation Code (NYCECC).

Fan array technology shall be used on all Air Handling Units. Provide one VFD per fan array and one VFD as backup, total of two VFDs per fan array. Do not provide bypass

on VFDs. The VFDs shall be programmed to operate all fans simultaneously and at the same ramp speeds. Each fan motor in the fan array shall have its own local disconnect. The VFDs shall swap at a determined time interval to equal out run time. All fans in a fan array system shall be provided with low pressure drop backdraft dampers that will prevent recirculating air when a fan is down due to maintenance or failure. Do not provide blank off plates in lieu of backdraft dampers.

Non-Ducted filter boxes shall have a minimum of 1 foot clearance. Ducted intake filter boxes shall have removable panels. This applies to V-Cube type Mammoth condenser water type units.

If unit is provided with factory mounted controls; the unit shall have ability for read/write access to the existing BMS system through BACnet or Modbus protocol.

Motor section shall have doors or removable panels that are 25% larger than the motor for maintenance access. All floor plating inside each compartment shall be sheetmetal. Provide hoist type access for maintenance purposes.

If a unit is a double stack unit with access doors/panels on an upper level of the unit, the unit shall be provided with a permanent walkway/catwalk for maintenance access. Ladders without a walkway/catwalk are not allowed.

Units are to be provided with access windows for each unit section. Lighting shall also be provided in each section. If unit is outdoors, lighting suitable for outdoor use (flood light type) shall be provided to illuminate all walkways/catwalks and access points.

Pre-assembled units shall be factory witness tested. Tests shall consist of: Unit Leakage, Coil Leakage, Deflection, Fan Vibration, and Acoustical.

Field assembled units shall have the same test criteria as factory witness test but shall be field tested by manufacturer.

Duct seal putty shall be used in all AHU conduit connections to VFDs, control enclosures, and other sensitive electronics.

Switches, dampers, gauges and other components shall be mercury-free in compliance with NYU Langone Health's Mercury Elimination Program.

On units that require UV lighting, AHU UV light sections shall be provided with UV protected glass so that personnel can look into unit section without damaging eyes.

Humidity valve actuators shall fail closed based through an auxiliary contact from the fan current sensor.

Stainless steel welded pans shall be installed under all AHU's and floor mounted CRAC/CRAH units that are inside of a building above the lowest floor. Pans are not required if flooring is waterproofed and floor is pitched to floor drains.

Air blenders shall be used in all mixed-air units. Air blenders shall be designed with low pressure drop. Discuss need of air blenders with facilities if design engineer is choosing to design a dual purpose heating/cooling coil as described in Cooling/Heating Coil section.

In any outdoor application that has a coil (Chiller, ACCU, Drycoolers, RTUs etc.) exposed to the outdoors that is within 30 miles of the ocean, specify coastal type with corrosion resistance.

For an AHU that serves Operating Rooms; the unit shall be designed to have a pre-filter (intake of unit) of MERV 8. The final filter (discharge of unit) shall be MERV 15. HEPA filtration shall be installed in the modular OR ceiling. If a modular ceiling is not being designed inside the operating room, discuss with facilities where HEPA filtration shall be installed.

Approved Manufacturers:

- a. Factory Assembled Custom Air Handling Units
 - 1) Air Enterprise
 - 2) Buffalo Air Handling
 - 3) Temtrol
 - 4) Ventrol
 - 5) Carrier
 - 6) Ingenia
 - 7) Alliance Air Products
 - 8) Haakon

- b. Packaged Roof-Mounted Air Handling Units
 - 1) Enviro-Tec
 - 2) Trane
 - 3) York/Johnson Controls
 - 4) Carrier
 - 5) Mammoth

- c. Packaged Roof-Mounted DX Air Handling Units
 - 1) Trane
 - 2) York/Johnson Controls
 - 3) Liebert
 - 4) Carrier
 - 5) Mammoth

- d. Packaged Self-Contained Chilled Water Air Handling Units
 - 1) Buffalo Air Handling
 - 2) Trane
 - 3) Ventrol
 - 4) Carrier
 - 5) Mammoth

- e. Packaged Self-Contained Computer Room Air Conditioning Units
Units shall not exceed 65db.
 - 1) Liebert
 - 2) APC
 - 3) Stulz
 - 4) Trane

 - f. Packaged Self-Contained Air Conditioning Units (Ceiling-Mounted)
Units shall not exceed 65db.
 - 1) Enviro-Tec
 - 2) Liebert
 - 3) United Coolair
 - 4) Daikin

 - g. Packaged Self-Contained DX Air Conditioning Units (Ceiling-Mounted)
Units shall not exceed 65db.
 - 1) Liebert
 - 2) Mammoth
 - 3) United Coolair
 - 4) Daikin

 - h. Spot Coolers (Data Closets)
 - 1) Movin Cool
6. Air Outlets
Any outlets that are to be installed in labs, Operating Rooms or any specialized medical space shall be specific to the usage of the room. Standard outlets are not allowed in these areas.

Plenum box connections to linear diffusers need to be clearly shown in details. Details shall clearly describe how connections shall be air sealed. Design engineer shall ensure detail is physically buildable.

Approved Manufacturers:

- a. Anemostat
- b. Krueger
- c. Nailor Industries
- d. Titus
- e. Ruskin

7. Air Volume Regulators

Approved Manufacturers:

- a. Anemostat
- b. Krueger
- c. Nailor Industries
- d. Titus

8. Baseboard Radiation (Steam/Water)

Approved Manufacturers:

- a. Rittling
- b. Slantfin
- c. Sterling Radiator
- d. Vulcan Radiator

9. Boilers

Approved Manufacturers:

- a. Condensing Modular
 - 1) Lochinvar
 - 2) Peerless
 - 3) Fulton
 - 4) Cleaver Brooks
- b. Fire Packaged Watertune
 - 1) Lochinvar
 - 2) Peerless
 - 3) Burnham
- c. Firetube Boilers up to 150,000lbs/hr
 - 1) Cleaver Brooks
- d. Heat Recovery Steam Generators / Waste Heat Boilers
 - 1) Rentech

10. Clean Steam Generators

Clean steam generators shall be steam to steam type. Screen control panels with PLC shall be provided. Shell shall be pitched to completely drain the condensate.

Approved Manufacturers:

- a. Diversified Heat Transfer DHT.
- b. Patterson-Kelley, Company.
- c. Acme Engineering Products, Inc.
- d. Precision Boilers, Inc.
- e. Armstrong
- f. Dri-Steam
- g. Cem-line

11. Chilled Beams (active)

Chilled beams shall have pressure independent control. Beams shall be provided with a pressure tap that can be used to measure the pressure differential between the primary air plenum and the room. The units shall be equipped with hinged perforated return grilles, an air bleed and drain valves. The connection of beams to the chilled water circuit shall be a maximum 18 inch long PTFE lined braided stainless steel hose having a rated operating pressure not less than 500 psig.

It is standard for all chilled beams to be supported by the wire hanging kit method.

Provide a minimum of 3 feet of straight or gradual radius between the primary air duct and the primary connection of the unit. Also avoid sharp bends on the primary air duct connection. Do not install the primary air volume damper directly to the primary air inlet connection. Flexible duct connections to the primary air inlet is not allowed.

Approved Manufacturers:

- a. Dadanco
- b. Carrier
- c. Titus
- d. Semco
- e. York
- f. Price

12. Chillers

If installing equipment on a roof, refer to Do's and Don'ts section for requirements.

Chiller redundancy to be reviewed by Facilities Operations. All new chillers shall be reviewed and approved by Facilities Operations. Provide hoist type access for maintenance purposes.

Chillers located outdoors shall have capabilities of operating low ambient temperature conditions.

Factory witness tests shall consist of all tests required under AHRI Standard 550. Chillers shall have a four point tests - 25%, 50%, 75% and 100% design load. FWT shall include lodging, meals and travel for two NYULH personnel. Chiller FWT shall also include safeties and shutdown testing.

Switches, dampers, gauges and other components shall be mercury-free in compliance with NYU Langone Health's Mercury Elimination Program.

In any outdoor application that has a coil (Chiller, ACCU, Drycoolers, RTUs etc.) exposed to the outdoors that is within 30 miles of the ocean, specify coastal type with corrosion resistance.

Approved Manufacturers:

- a. Centrifugal
 - 1) Carrier
 - 2) York/Johnson Controls
 - 3) Trane
 - 4) Carrier
- b. Absorption
 - 1) York/Johnson Controls
 - 2) Carrier
 - 3) Trane
- c. Modular Air Cooled
 - 1) ArcticChill
 - 2) Carrier
 - 3) Multistack
 - 4) York/Johnson Controls
 - 5) Trane
- d. Modular Water Cooled
 - 1) ArcticChill
 - 2) Multistack
 - 3) York/Johnson Controls
- e. Packaged Air Cooled
 - 1) Carrier
 - 2) York/Johnson Controls
 - 3) Trane
- f. Magnetic Levitation
 - 1) York/Johnson Controls
 - 2) Daikin
 - 3) Trane

13. Condensate Pumps

Steam condensate pumps shall have pump status monitored at BMS as well as high level alarm annunciated at BMS. This typically required additional relays to be designed.

Approved Manufacturers:

- a. Cold Condensate
 - 1) Federal
 - 2) Hartell
 - 3) Little Giant

- b. Hot Condensate (Low Pressure Steam Return)
 - 1) Armstrong International
 - 2) Bell & Gossett
 - 3) Federal Pump
 - 4) Weinman

14. Cooling/Heating Coils

Coil pressure rating shall be designed to 400 psi at an ANSI pressure class of 300 lbs. for Manhattan campus primary chilled water system.

All coils shall be copper tube and copper fin. Fins shall not be thinner than 0.0095" and tubes shall have a minimum 0.035" wall thickness. Dielectric fittings shall be installed between all dissimilar metals. If there is a shortage of copper, aluminum fins are allowable however this needs to be discussed with NYULH Facilities before proceeding with design. Construction of aluminum fin coils shall have copper tube with a minimum wall thickness of 0.035" and aluminum fin with a minimum 0.0095" thickness.

A corrosion prevention coating (Electrofin or similar) shall be applied to any coil that is in a 100% outdoor air unit and all aluminum fin coils.

All coils shall be drainable (drain downs downstream of isolation valve ¾" hose bib) and have means of removal for service or replacement. Coils shall be pitched to a low point for draining purposes. If coils have different levels, all levels shall have separate drain pans. Coils shall have capability to be removed without removing any piping trim. All coils shall have clear access for removal. Multi coils shall be staggered for ability to be removed on the same side of unit. Provide hoist type access for maintenance purposes. Vents shall be provided at the top of the coil with drains at the bottom, vent and drain shall exist between the coil's isolation valves.

Cooling Coils must have a stainless steel condensate pan pitched in three directions toward drain. Drain pan nipples shall be stainless steel with dielectric fittings connecting to a drain plug.

If return air is coming from the top, the coils shall be designed to have a top and bottom section. If return air is coming from the side, the coils shall be designed to have a left and right section.

Separate Freezestats shall be provided on EACH section of coil within a unit. If a unit has multiple coils, each coil section shall be provided with its own control valve.

Freeze type plug valves are not allowed.

Coils to be provided with a full size manual bypass ball or gate valve.

Traps for cooling and steam coils shall have proper heights for the removal of condensate.

Coils not specifically listed in approved manufacturers below are acceptable only if the Air Handling manufacturer builds and tests the coils in their factory.

In any outdoor application that has a coil (Chiller, ACCU, Drycoolers, RTUs etc.) exposed to the outdoors that is within 30 miles of the ocean, specify coastal type with corrosion resistance.

Hot water/Chilled water coils shall not be bottom fed. These coils shall be top or side fed.

Design engineer to consider utilizing dual purpose CHW/HW coils to combine coils in AHUs. Engineer shall perform an analysis on applicability of such a coil and present to the corresponding campus facility team for review.

Approved Manufacturers:

- a. Water/Steam
 - 1) Aerofin
 - 2) Heat Craft
 - 3) Temtrol
 - 4) RAE

15. Cooling Towers

If installing equipment on a roof, refer to Do's and Don'ts section for requirements.

All towers shall have accessible fan motors for removal. Catwalks shall be provided for fan motors that are installed on the outside of the unit. Provide means of removal of fan motor. Railings shall always be provided on top of the unit. Ladders shall be provided for access to the top of the unit. Freeze protection (steam or electric) shall be provided on towers that will not be drained down during the winter season – freeze protection pump shall be provided on a case by case basis as secondary protection.

Major cooling towers shall be induced draft type and have stainless steel basins with PVC piping inside. If towers have multiple cells, each cell shall have means of walking between each cell. Catwalks shall be installed inside all cells for maintenance. Catwalks/platform shall be installed around entirety of cooling tower at the level of the bottom of the basin.

Minor cooling towers shall be force draft type and have stainless steel basins with PVC piping inside. Catwalks/platform shall be installed around entirety of cooling tower at the level of the bottom of the basin.

¾" hose bib shall be installed for cleaning purposes.

All cooling towers shall be reviewed and approved by Facilities Operations.

Approved Manufacturers:

- a. Marley
- b. Baltimore Aircoil Company
- c. Evapco

16. Controllers (Water Level)

Controllers shall be floats or digital type. Design shall be discussed with Facilities Operations.

Floats, controls, switches, dampers, gauges and other components shall be mercury-free in compliance with NYU Langone Health's Mercury Elimination Program.

Approved Manufacturers:

- a. McDonnell Miller
- b. B&W
- c. Magnatrol International, Inc.

17. Dampers (ALD's)

Shafts of dampers shall be notched to indicate the position of the damper blade. Damper adjustment hardware and actuators shall extend past ductwork insulation.

Provide Access Doors for damper blades and actuator (if access is an issue). If actuator has to be installed inside ductwork due to size requirements, the design shall be reviewed and approved by Facilities Operations.

Dampers and other components shall be mercury-free in compliance with NYU Langone Health's Mercury Elimination Program.

Double actuators are not allowed. Actuators shall be sized to provide proper torque via one actuator.

Approved Manufacturers:

- a. Arlan
- b. Imperial
- c. Ruskin
- d. Tamco

18. Dampers (Dynamic Fire/Smoke)

All fire smoke dampers to be full throat and shall not obstruct the air stream or reduce the area of the duct in any manner. Shafts of dampers shall be notched to indicate the position of the damper blade.

Fire Smoke Dampers shall be provided with limit switches.

Dampers and other components shall be mercury-free in compliance with NYU Langone Health's Mercury Elimination Program.

All access doors for FSDs shall include a label on the door indicating what the access is for.

Approved Manufacturers:

- a. Arlan
- b. Imperial
- c. Ruskin
- d. Tamco
- e. Pottorff
- f. Honeywell

19. Expansion Compensation

Expansion compensators shall be designed and shown on drawings with proper guiding and anchors.

Approved Manufacturers:

- a. Ball Type Expansion Joints
 - 1) Advanced Thermal Systems
 - 2) Hyspan-Barco
- b. Braided Type Expansion Loops
 - 1) Metraflex
- c. Corrugated Type Expansion Joints
 - 1) Hyspan-Barco
 - 2) Keflex
 - 3) Metraflex
- d. Slip Type Expansion Joints
 - 1) Hyspan-Barco
 - 2) Metraflex

20. Expansion Tanks

Expansion tanks shall have waterside and airside gauges on bladder type tanks. Drain points shall be provided on waterside section. All expansion tanks shall have replaceable bladders.

Approved Manufacturers:

- a. Adamson
- b. Amtrol
- c. Bell & Gossett
- d. John Woods
- e. RECO
- f. TACO

21. Fans

If installing equipment on a roof, refer to Do's and Don'ts section for requirements.

Spring type vibration isolators shall always be provided. Neoprene type isolators can be provided for fans less than 100lbs. If neoprene is used, the design shall be reviewed and approved by Facilities Operations.

Motors which are located on the outside of the fan housing shall have an internal access point to provide access to internal sheave. Provide hoist type access for maintenance purposes.

Patient isolation rooms shall have a dedicated exhaust system, which shall not be picked up by the air handling unit.

Fumehood chemical exhaust shall be stainless steel welded ductwork. All fume hood risers shall be pitched back to the chemical fume hood. Fume hoods shall be tested to ANSI/ASHRAE 110 standards.

Bearings shall have a life grade of L5 with a minimum of 50,000 hours.

Fan inlet boxes shall follow SMACNA HVAC Systems Design Handbook and shall not be field fabricated without verification the SMACNA standards were followed.

Belt driven fan shall not be provided with variable pulleys if equipped with a VFD. Only fixed pulley shall be allowed on such systems.

Approved Manufacturers:

- a. Howden-Buffalo
- b. Strobic Air
- c. Greenheck
- d. Cook
- e. PennBarry
- f. Twin City
- g. Aerovent

22. Fan-Powered Boxes

Fan-Powered Boxes shall have pressure independent control. Units shall be designed with a local disconnect switch.

Approved Manufacturers:

- a. Anemostat
- b. Nailor Industries
- c. Titus

23. Fan Coil Units

Provide with 2-way controls and condensate pump (or gravity drain). Separate stainless steel drain pan shall be installed underneath unit.

Pumps, switches, dampers, gauges and other components shall be mercury-free in compliance with NYU Langone Health’s Mercury Elimination Program.

Approved Manufacturers:

- a. York/Johnson Controls
- b. Liebert
- c. Data Aire
- d. International

24. Firestopping Products

Firestopping products shall not be used unless required for fire or smoke barriers. The following shall not be specified without approval from NYU Langone’s division of EH&S:

- Chemicals that are known (IARC group 1) or probable (IARC group 2a) human carcinogens.
- Hazardous substances listed in OSHA 1910 subpart Z.
- Products containing volatile organic compounds (VOCs) in excess of 50 grams/liter.
- Products whose Safety Data Sheet (SDS) rates health, fire and/or reactivity as exceeding “1” on a scale of 0 to 4.
- Products emitting strong odors.

Approved Manufacturers:

- a. Hilti

25. Flow Measuring Devices

Floats, controls, switches, dampers, gauges and other components shall be mercury-free in compliance with NYU Langone Health’s Mercury Elimination Program.

When a metered feed to a building is removed or changed, the new feed shall be similarly metered.

Hot wire type air flow measurement devices are not acceptable.

Approved Manufacturers:

- a. Air Systems
 - 1) Air Monitor Corporation
 - 2) Tek-Air Systems, Inc.
 - 3) Paragon Controls
 - 4) Ebtron
- b. Water Systems (Permanently Installed Clamp On Ultrasonic)
 - 1) Flexim

- c. Water Systems (Permanently Installed Electromagnetic Flow Meter)
 - 1) Krohne
 - 2) Yokogawa
 - 3) Emerson
 - 4) Siemens

 - d. Steam Systems (Insertion Turbine or Vortex or Clamp On Ultrasonic)
 - 1) Flexim
 - 2) Spirax Sarco ILVA
 - 3) Rosemount
 - 4) Vortek Instruments
26. Fuel Oil Pumping Systems
Pumping system shall be installed in a space that will provide access for periodic maintenance including removal of motors, impellers, and accessories. In flood prone area (refer to Facilities Department for flood prone locations) provide water tight enclosure that will allow the pumps to operate during a flood. Controls and all power conduits to be within water tight installations until outside of flood zone.
- Fuel oil containment piping which is horizontal shall be pitched back to leak containment drum. Vertical fuel oil risers shall also drain into leak containment drum. Horizontal containment shall be a pipe in pipe – no other means of containment is allowed.
- Approved Manufacturers:
- a. ISP
 - b. IMO
 - c. Deval
 - d. Viking
27. Fuel Oil Specialties
Approved Manufacturers:
- a. ISP
 - b. Preferred Utilities Mfg. Corp.
28. Fuel Oil Tanks
Fuel oil tank shall be bolted to the structure to prevent floating in case of a flood. All preventable flood requirements shall be analyzed if fuel oil tank is to be installed in a flood prone area (refer to Facilities Department for flood prone locations).
- Approved Manufacturers:
- a. Fiberglass
 - 1) Xerxes Corp.
 - 2) Cardinal Fiberglass Industries
 - 3) Containment Solutions

- b. Steel
 - 1) ISP
 - 2) Highland Tank & Mfg. Co.
 - 3) Adamson Global Technology Corporation
 - 4) Cardinal Tank Corporation
29. Fuel Oil Tank Gauging and Leak Detection Systems
Approved Manufacturers:
 - a. ISP
 - b. Veeder-Root
30. Freezestats
See controls subsection for Low Temperature Switches.
31. Hangers, Anchors and Guides
All exposed threaded rods shall be capped with an orange protective cap either rubber or plastic. All threaded rods shall be cut down to an inch of final nut – rods shall not be left at full length for safety reasons.
32. Heat Exchangers
For shell and tube heat exchangers, relief valves shall be located on the hot and cold side of heat exchanger and sized to the working pressure of the system.

Plate and Frame heat exchangers shall be located on a housekeeping pad. No equipment shall be installed on the plate side of a heat exchanger – proper access for removal of plates shall always be maintained.

Heat exchangers shall be provided with strapped or clipped removable shrouds.

Heat exchangers shall be AHRI certified

Approved Manufacturers:
 - a. Plate-and-Frame
 - 1) Alpha-Laval
 - 2) Plate Concepts
 - 3) Bell and Gossett
 - b. Shell-and-Tube
 - 1) Bell & Gossett
33. Heat Trace
Refer to electrical guidelines for details.
34. Humidifiers
Humidifiers shall be supplied with Humidistat and also an airflow switch for preventing humidifier operation without airflow. Humidistat shall be designed to be controlled via a cascaded loop. Humidifiers shall be resistive type not electrode type.

Approved Manufacturers:

- a. Steam
 - 1) Armstrong
 - 2) Dri Steam
 - 3) Nortec

- b. Water Spray (cannot be used in Article 28 spaces)
 - 1) Armstrong
 - 2) Hermidifier
 - 3) Cold Fog

35. Insulation (Duct and Pipe)

All supply ductwork shall be insulated on the outside. No acoustic insulation is allowed inside the ductwork unless encapsulated with a mylar, tedlar, or approved equivalent type membrane. Insulation shall not cover any damper adjustment hardware.

All acoustical lining on the inside of any ducts to be reviewed with Facilities Operations.

Piping insulation shall comply with latest codes and energy conservation codes.

Ductwork located outside shall have proper weatherproofing for use outdoors. Outdoor ductwork must have internal rigid supports to create a pitched top and prevent water accumulation on top of the duct.

Steam station and steam piping shall have insulation designed such that no point of insulation is greater than 10 degrees above ambient temperature.

The following ductwork shall be insulated:

- Supply Air.
- Outdoor air.
- Return located in unconditioned space.
- Type I, commercial, kitchen hood exhaust.
- Oven and warewash exhaust.
- Exhaust between isolation damper and penetration of building exterior.
- Supply and return located outdoors.

Generator exhausts located indoors shall be insulated with Calcium Silicate.

Approved Manufacturers:

- a. Armacell
- b. Armstrong
- c. Knauf
- d. Johns-Manville
- e. Owens-Corning Fiberglas (O-C-F)
- f. P.P.G. (Pittsburgh Plate Glass)

36. Insulation Adhesives

The following shall not be specified without approval from NYU Langone’s division of EH&S:

- Chemicals that are known (IARC group 1) or probable (IARC group 2a) human carcinogens.
- Hazardous substances listed in OSHA 1910 subpart Z.
- Products containing volatile organic compounds (VOCs) in excess of 50 grams/liter.
- Products whose Safety Data Sheet (SDS) rates health, fire and/or reactivity as exceeding “1” on a scale of 0 to 4.
- Products emitting strong odors.

Approved Manufacturers:

- a. Benjamin Foster Company
- b. Elgen
- c. Venture Tape Corp

37. Insulation Pipe Shields

Approved Manufacturers:

- a. Buckaroos, Inc.
- b. Pipe Shields Inc.
- c. Taylor Pipe Supports

38. Meters and Gauges

Controls, thermometers, meters, gauges and other components shall be mercury-free in compliance with NYU Langone Health’s Mercury Elimination Program.

No gauge cocks allowed.

Compound gauges shall be used on suction side of pumps when required due to system pressure.

Temperature Scale Ranges:

- Chilled-Water Piping: 0 to 100 deg F
- Condenser-Water Piping: 0 to 150 deg F
- Heating, Hot-Water Piping: 20 to 250 deg F
- Steam-Condensate Piping: 0 to 250 deg F
- Steam Piping: 212 to 500 deg F

Pressure Scale Ranges:

Design engineer shall specify proper scales based on operating pressures.

Approved Manufacturers:

- a. Instrument Test Ports
 - 1) Peterson Equipment
 - 2) Sisco
 - 3) Watts Regulator

- b. Pressure Gauges 1.00% Accuracy
 - 1) Ashcroft
 - 2) Trerice
 - 3) Weiss
 - 4) Weksler

- c. Pressure Switches
 - 1) Barksdale
 - 2) Dwyer
 - 3) Mercoïd

- d. Thermometers 1.00% Accuracy
 - 1) Trerice
 - 2) Weiss
 - 3) Weksler

39. Motors

Conform to NEMA MG 1. Motors shall not operate continuously at a service factor greater than 1. Design to a service factor of a minimum of 1.15. Provide hoist type access for maintenance purposes.

Motors to be with permanently greased bearings (preferred). If permanently greased bearings are not provided, grease ports shall be provided with adequate access – grease capillaries are not allowed.

Bearings shall have a life grade of L10 with a minimum of 200,000 hours. If motor is part of a fan array system and over-hertzing is being implemented, L10 life shall be greater than 200,000 hours.

If motor is part of a VFD system, the motor shall be inverter duty rated.

Motors enclosures shall be TEFC.

Approved Manufacturers:

a. Standard Efficiency (Less Than 1 hp)

- 1) Baldor
- 2) General Electric
- 3) Toshiba
- 4) U.S. Motors
- 5) Dayton
- 6) Marathon
- 7) Weg

b. Premium Efficiency (1 hp and Above)

- 1) Baldor
- 2) General Electric
- 3) Toshiba
- 4) U.S. Motors
- 5) Dayton
- 6) Marathon
- 7) Weg

40. Motor Starters

Approved Manufacturers:

- a. Asea Brown Boveri (ABB)
- b. ASCO
- c. Allen Bradley
- d. Siemens
- e. Yaskawa Electric America

41. Motor Control Centers

See Electrical Design Guidelines

42. Motor Controllers Variable Speed (VFD)

Provide two VFDs – one lead and one lag unless part of a fan array system – see Air Handling Unit subsection for fan array VFDs. VFDs shall be reviewed and approved by Facilities Operations. All conduits in a controlled enclosure or electrical enclosure shall have sealed conduits.

VFDs shall not be installed under any piping trim or joints. If VFD is installed under piping due to physical install constraints, NEMA 4 or 6 shall be used. All locations of VFDs that are below piping shall be approved by Facilities Operations.

Harmonic Filtering is required on all variable speed drives. Design engineer to discuss with Facilities Management prior to design if active or passive harmonic filtering to be required.

Field Testing on all VFDs powering 25hp motors and larger shall be provided and confirmed that Total Harmonic Distortion does not exceed 5%. At the point of common connection, current Total Harmonic Distortion shall not exceed 10%.

Startup and setup shall be done by the current NYU Langone VFD vendor. Contact Facilities Operations for current campus vendor.

Duct seal putty shall be used on all conduit connections to air handling VFDs.

Do not select VFDs with a Bluetooth option.

VFDs that are backed up by emergency power shall be selected and programmed to ride through a voltage dip, manual switch from normal power to emergency power (and vice versa), and ride through an automatic switch from normal power to emergency power (and vice versa).

Approved Manufacturers:

- a. Asea Brown Boveri (ABB)
- b. Yaskawa Electric America
- c. Danfoss

43. Orifice Steam Traps (Venturi Orifice Type)

Steam traps to have unions upstream and downstream of traps

Approved Manufacturers:

- a. Steam Gard

44. Pipe and Fittings

Dielectric fittings shall be installed between all dissimilar metals. Piping ball joints for movement between buildings shall be flanged and not welded.

Steam pipe gaskets are to be solid graphite type (Equalseal EQ FG-P). Spiral wound gaskets will not be accepted.

For piping within technology space, no piping shall be provided in the technology space unless it is required for equipment within the room. All piping that is in the technology room must not be routed over technology equipment. All valves and metering associated with piping must have a drip pan located underneath with water detection.

Pro-press can be considered on a case by case basis. Discuss this request with NYULH Engineering prior to design.

- a. Mechanical Couplings for Grooved Pipe
 - 1) Grooved piping shall be discussed with Facilities Operations and shall be based on a project-by-project basis prior to its use in design.
- b. Gaskets
 - 1) Garlock
 - 2) Flexitallic
 - 3) Lamons
 - 4) Equalseal EQ FG-P (All Steam Piping shall be this type.)

45. Pressure-Regulating Valves/Stations

High, Low, Medium pressure steam pipe gaskets are to be graphite type. Flexseal gaskets will not be accepted.

All steam station pneumatic lines must match the size of the controller's pneumatic connection and be run as copper hard piping, soft tubing not accepted.

Approved Manufacturers:

a. Steam

- 1) Leslie
- 2) Fairchild
- 3) Fische
- 4) Circor
- 5) Warren Controls

b. Water

- 1) Leslie
- 2) Cla-Val
- 3) Watts

46. Pumps

All pumps shall be premium efficiency. Pumps shall not be provided with triple-duty valves unless install restrictions require such an install. If triple-duty valves are required, they shall be reviewed and approved by Facilities Operations. Pumps shall be provided with either a strainer or suction diffusers with drain. Pump trim shall not have a balancing valve if pump will be provided with a VFD.

Piping and pumps are to be independently supported. Spring type isolators on piping shall be recommended by acoustical consultant. If no consultant is on project, all piping within 50 feet of pump shall have spring type isolators.

Install pumps in such a way to allow periodic maintenance which includes removal of motors, impellers and couplings. Pumps are required to be able to be drained down.

Provide hoist type access for maintenance purposes.

Bearings shall have a life grade of L10 with a minimum of 200,000 hours.

Approved Manufacturers:

a. Horizontal Split, End Suction and In-Line

- 1) Armstrong
- 2) Aurora
- 3) Bell & Gossett
- 4) Gould
- 5) Peerless
- 6) Weinman
- 7) Grundfos

- b. Fuel Oil
 - 1) IMO
 - 2) Viking
 - 3) Simplex

47. Radiant Heating Systems

Unit shall be supplied with a wall thermostat and a manually operated on-off switch.

Approved Manufacturers:

- a. Ceiling
 - 1) Rittling
 - 2) Runtal

- b. Floor
 - 1) Aero Tech
 - 2) Airtex
 - 3) Aztec
 - 4) Uponor

48. Refrigerant Monitoring Systems

Relay outputs for alarms and control shall be provided to connect to BMS. The unit shall also be provided with visual and audible alarms at the panel. Monitoring system shall have multi point capabilities.

Approved Manufacturers:

- a. Mine Safety Appliances Company (MSA)

49. Sound Traps

Sound traps shall only be installed if required per code for a maximum NC level of a room.

Approved Manufacturers:

- a. I.A.C. (Industrial Acoustics Co.)
- b. Dynasonics
- c. Vibro-Acoustics
- d. Price

50. Steam Traps – See also Orifice steam traps

Steam traps to have unions upstream and downstream of traps

Approved Manufacturers:

- a. Armstrong
- b. Sarco

51. Steam Piping

- a. All steam traps shall be steamgard venturi orifice type wherever possible. The design engineer shall review each trap with the manufacturer to confirm if orifice-type traps can be used.
- b. Steam traps shall be provided at all low points, end of mains, riser heels and at equipment connections. Base of drip legs to be provided with separate blowdown valves.
- c. Ensure all components of the details are installed (unions, shutoff valve, check valve, etc.)
- d. All piping from coils shall be pitched to the inlet of the condensate pump (no trapped piping).
- e. Drip legs shall be provided periodically for long runs of pipe at intervals between 100 to 125 feet.
- f. Drip legs shall be no less than half the size of the pipe it serves.
- g. Blow-off valves to be provided at all drip legs and at the base of all risers.
- h. Flash tank trap shall be located 6 inches above the water level of the tank. Flash tanks to be provided with F&T trap.
- i. Test-t shall be provided on all condensate piping downstream of steam trap and upstream of condensate shut off / check valve.
- j. Warmup bypass shall be provided for all steam valves 6 inches and larger.
- k. High pressure steam shutoff valves at the incoming service to each building shall be provided with two shutoff valves for safety purposes.
- l. All steam piping shall be insulated.
- m. Condensate pumps and flash tanks shall be vented to atmosphere.
- n. Condensate piping exposed to the outdoors shall be heat traced.
- o. Outdoor steam and condensate piping shall have two layers of insulation.
- p. High pressure steam shutoff valves shall be high performance OS&Y valves (not butterfly valves).
- q. Prior to startup – A/E team and construction team shall review NYULH Steam Insulation Quality Control Checklist – obtain checklist from Facilities Management.

52. Strainers

Strainers installed on steam piping shall not be installed in the vertical direction (facing towards ground). Steam strainers shall be installed to be in line with the horizontal piping such that when looking at the pipe and strainer, the clean out shall be facing directly towards you.

Dielectric fittings shall be installed between all dissimilar metals.

Approved Manufacturers:

- a. Fabrotech
- b. Hoffman
- c. McAlear Mfg. Co.
- d. Metraflex
- e. Mueller
- f. Sarco
- g. Titan
- h. Yarway

53. System Identification

Equipment Labels shall be high quality.

<p>In all MERs, pipe insulation and conduits shall have colored PVC jacketing per the colors below. Colored PVC jacketing shall be installed on all piping 2” and above.</p> <p>Approved PVC Jacketing Manufacturers:</p> <ul style="list-style-type: none"> a. Johns Manville b. Proto c. Speedline d. P.I.C. Plastics 		
Chilled Water – Primary	Light Cyan	
Chilled Water – Secondary	Light Cyan	
Compressors	Light Gray	
Condenser Water	Yellow	
Domestic Water – Cold	Pea Green	
Domestic Water- Hot	Medium Gray	
Electrical	Blue	
Fans	Dark Green	
Glycol	Off-White	
Refrigerant	White	
Reheat Water	Medium Green	
Sprinkler and Standpipe	Red	
Steam	Marigold	
Steam Condensate	Red-Orange	
Floor Guard	Dark Gray	
Hot Water Heating	Yellow	
Valves and Trim	Black	
Waste Line	Dark Brown	

<p>Pipe Labels shall be installed every 5 feet in concealed areas and every 10 feet in un-concealed areas and shall be self-adhesive labels with direction-of-flow arrows and the name of the service printed in letters not less than 1 inch high for pipe 2-1/2 inches and smaller, 2 inches high for 3 inch pipe and larger. Markers shall have backgrounds of different colors for the various service groups. Pipe labels shall be color coded as follows:</p>		
Fire Quenching Liquids	White on Red	TEXT
Toxic and Corrosive Fluids	Black on Orange	TEXT
Flammable Fluids	Black on Yellow	TEXT
Combustible Fluids	White on Brown	TEXT
Potable, Cooling, Boiler Feed and other Water	White on Green	TEXT
Compressed Air	White on Blue	TEXT
Steam	Black on Yellow	TEXT
Chilled Water	White on Cyan	TEXT
Hot Water / Reheat Hot Water	White on Red	TEXT
Condensate	Black on Orange	TEXT
Fuel Oil	White on Brown	TEXT
<p>Duct Labels shall be installed every 20 feet and shall be self-adhesive labels with direction-of-flow arrows and the name of the service printed in black letters not less than 4 inches high.</p>		
Outside Air	White on Blue	TEXT
General Exhaust	Black on White	TEXT
Toilet Exhaust	Black on Orange	TEXT
Return Air	Black on Yellow	TEXT
Supply Air	White on Green	TEXT
BMS	Black on Orange	TEXT

Valve Tags: Each valve tag shall be 3 inch diameter or square, brass, aluminum or stainless steel. Lettering shall be viewable from a distance of 10 feet. A schedule showing all valve locations, size, and service shall be provided.

Approved Manufacturers:

- a. Brimar Industries Incorporated
- b. Seton Nameplate Corp.
- c. W. H. Brady Co.

54. Temperature Controlled Rooms (walk in box / cold room / environmental box)
Refer to the Miscellaneous subsection within the Architectural section of these Design Guidelines for all engineering requirements.

55. Unit Heaters

Unit shall be supplied with a unit mounted thermostat.

Approved Manufacturers:

- a. Electric
 - 1) Berko
 - 2) Brasch
 - 3) Chromalox
 - 4) Indeeco
 - 5) Dayton
- b. Steam/Water
 - 1) Modine
 - 2) Rittling
 - 3) Sterling

56. Valves

Dielectric fittings shall be installed between all dissimilar metals.

For Manhattan Main Campus: All campus primary chilled water valves to be 300lb rated. Secondary chilled water valves shall be designed based upon their designed system pressure. Primary CHW service and steam service shall all be stainless steel ball valves.

All system pressures shall be specified on design drawings. Ball valves (2 ½" maximum) must be used for manual isolation on all chilled water, secondary water, reheat water and radiation water systems. Butterfly valves are to be used on larger piping (3" and above).

All valves and piping systems shall be designed to be able to close off to atmospheric pressure on either side of valve. All valves 3" and larger shall be pressure checked and bench tested at the factory. Factory shall provide a certified report based on testing. Testing shall show that valve can hold rated pressure based on atmospheric pressure on either side of valve.

Any valve that is above 7 feet shall be provided with a chain wheel for manipulation of valve from the floor.

All high pressure steam isolation valves shall have manual warmup valves for startup. High Pressure steam valves shall be high performance OS&Y gate valves – butterfly valves are not allowed. Valves shall be rated to 500 degrees F.

Approved Manufacturers:

- a. Balanced Check
 - 1) Fabrotech
 - 2) Hager
 - 3) Mueller

- b. Balancing Valves (Water)
 - 1) T & A
 - 2) Armstrong
 - 3) Autoflow
 - 4) Flow Design
 - 5) Milliken Valve Company, Inc.
 - 6) Bell and Gosset

- c. Ball Type
 - 1) Apollo
 - 2) Jamesbury
 - 3) Milwaukee
 - 4) Rockwell

- d. Butterfly
 - 1) DeZurik
 - 2) Flow Seal
 - 3) Bray
 - 4) Jamesbury
 - 5) Keystone
 - 6) W.K.M.

- e. Pressure Relief Valves
Provide at each expansion tank, plate-and-frame heat exchanger or any pressurized water vessel, and as required by Code. Relief valve shall match maximum allowable working pressure of piece of equipment. Relief piping shall be sized according to outlet size of relief valve and shall be piped to floor not floor drain. Steam relief vents shall be piped to atmosphere.
 - 1) Apollo
 - 2) Consolidated
 - 3) Farris
 - 4) Fulflo Specialties Co.
 - 5) Kunkle
 - 6) Lunkenheimer
 - 7) Watts
 - 8) Aquatrol series 69 (water)
 - 9) Aquatrol series 740 (steam)

- f. Soft-Seated
 - 1) Bray
 - 2) DeZurik
 - 3) Keystone
 - 4) Milwaukee

- g. Swing Check
 - 1) Crane
 - 2) Grinnell
 - 3) Hammond (I.B. Series only)
 - 4) Milwaukee
 - 5) Powell
 - 6) Rockwell-Nordstrom
 - 7) Stockham
 - 8) Walworth

- h. Globe Valves
 - 1) Crane
 - 2) Grinnell
 - 3) Hammond (I.B. Series only)
 - 4) Milwaukee
 - 5) Nordstrom
 - 6) Powell

- i. Plug Valves (Lubricated Type)
 - 1) DeZurik
 - 2) Milliken Valve Company, Inc.
 - 3) Nordstrom
 - 4) Walworth

- j. Plug Valves (Non-Lubricated Type)
 - 1) DeZurik
 - 2) Homestead
 - 3) Milliken Valve Company, Inc.

- k. Solenoid Valves
 - 1) ASCO

- l. Combination Valves
 - 1) Victaulic

- m. Gate Valves
 - 1) Crane

57. Variable Air Volume

Variable Air Volume Boxes shall have pressure independent control. All VAVs shall have a local disconnect switch.

All VAVs shall be marked with individual equipment ID's. This shall be specified on design drawings as well. Design drawings equipment schedule for VAVs shall be specific and general based on size.

Supply boxes with reheat coils shall have an access door upstream and downstream of the coil for cleaning purposes. Supply boxes without reheat coils shall have an access door for the damper. Exhaust boxes shall have an access door upstream of the cross flow sensors for cleaning purposes.

There shall be a maximum of 4 rooms per one VAV. These rooms shall be typical spaces and not corner spaces. Corner rooms shall have their own VAV box.

Access doors shall not be hinged.

VAV boxes that include reheat coils shall have temperature and pressure gauges. These can be combination temp/pressure gauge. The reheat coil trim shall also include vents and drains. Coils shall not have bypasses for flushing purposes. Provide ball valve type hose bibs upstream of the supply trim and downstream of return trim so that the contractor can install flex hoses to circulate and then remove so that there is no possibility of leaving a bypass open. The hose bibs can also be used for high point vents or drains. The hot water return piping shall have an isolation ball valve downstream of the balancing valve.

Inlets to VAV at medium pressure ductwork shall not exceed 0.2" ESP or 2,000 FPM.

Removable velocity wing sensor shall be provided if Anemostat is selected as the VAV box.

Approved Manufacturers Non Critical Applications:

- a. Anemostat
- b. Nailor Industries
- c. Titus

Approved Manufacturers Critical Applications:

- a. LCS

58. Variable Frequency Drives

See Motor Controllers Variable Speed (VFD) subsection

59. Variable Refrigerant Flow System (VRF)

If installing equipment on a roof, refer to Do's and Don'ts section for requirements.

Outdoor Unit (Condenser)

All variable refrigerant flow system (VRF) components shall be of the same manufacturer. The unit shall be factory assembled and prewired with all necessary electronic and refrigerant controls. The unit internal controls shall interface with the base building, building management system (BACnet, Modbus, etc.).

All refrigerant and gas lines shall be insulated with Armorflex (1/2" or more).

The unit shall be provided with a minimum of the following safety devices; high pressure switch, control circuit fuses, crankcase heaters, fusible plug, overload relay, inverter overload protector, thermal compressor protectors, thermal fan motor protectors, overcurrent protection for the inverter and anti-short cycling timers. In the event of power failure the system shall store all settings and programs so reprogramming is not required. The system shall automatically restart operation after power failure.

The compressor shall be hermetic digital scroll and the inverter shall permit a capacity control range from 10% to 100%.

The outdoor fan shall be direct drive variable speed propeller type and configured for vertical discharge airflow. The fan motor shall have inherent protection and have permanently lubricated bearings.

The condenser coil shall be copper tubes with mechanically bonded aluminum fins and aluminum end casings. The coils shall be applied with a corrosion resistant coating.

Ensure refrigerant piping is brazed (do not use flux when brazing copper to copper refrigerant piping)

Branch Controller

The branch controller shall have sufficient number of ports as required for connection to zoned equipment. The unit shall contain piping, valves, and controls to divert refrigerant controlling each port to operate in either a heating or cooling mode. Units shall be completely factory assembled, internally piped and wired.

Branch controllers shall have factory installed control boards that interface with the VRF equipment controls and shall perform all functions to effectively and efficiently control simultaneous heat and cooling. Isolation valves shall be field supplied and installed for ease of service to the branch controller without evacuating the entire system refrigerant charge.

Indoor Fan Coil Units

The indoor fan coil unit shall be factory assembled, wired and run tested. Contained within the unit shall be all factory wiring, piping, electronic modulating linear expansion device, control circuit board and fan motor. The indoor fan coil unit shall have an auto restart function. Indoor fan coil unit and refrigerant pipes shall be charged with dehydrated air before shipment from the factory.

The indoor fan coil unit shall be direct-drive type with a minimum of three (3) fan speeds. The fan motor shall be ECM type.

A condensate drain and pan shall be installed under the coil with leak detection device (in instances where condensate cannot be piped to drain). Provide a factory installed / wired condensate pump with integral check valve.

Provide wall mounted programmable thermostat for each indoor fan coil unit (unless multiple units will be grouped and control to one (1) thermostat).

Ensure all indoor fan coil unit DIP switches (local at each unit) are set to monitor room/space temperature (ceiling mounted units typically set to read return air temperature).

Approved Manufacturers

- a. Daikin
- b. Mitsubishi
- c. Toshiba
- d. LG

60. Vibration Isolators

Vibration isolators are to be installed on all rotating equipment including fans, air handling units, chillers, cooling towers, pumps, etc. Piping shall have braided vibration isolators unless piping is isolated with spring type isolators within a minimum of 50 feet of pump.

All piping in a mechanical plant shall be isolated with spring type isolators.

Approved Manufacturers:

- a. Mason Industries
- b. Amber Booth
- c. Kinnetics Noise Control, Inc.
- d. Vibration Eliminator Co.
- e. Vibration Mountings and Controls

61. Water Filtration

Sand filtration shall be installed on Condenser Water. All other systems shall have pot feeders. Sand filters shall have backwash capabilities.

All water filtration to be capable of filtering a minimum of 10% of total flow. Pot feeders to have 5 micron filtration with a coupon rack.

All water filtration shall be reviewed and approved by Facilities Operations.

Approved Manufacturers:

- a. Ameri Water
- b. Chemworks
- c. Diamond Water Systems, Inc.

62. Waterproof Sleeves

Approved Manufacturers:

- a. Link Seal
- b. Zurn

63. Water Source Heat Pumps

Approved Manufacturers:

- a. AAON
- b. Carrier
- c. Mitsubishi

64. Water Treatment/Cleaning

Open loop systems shall have an automatic chemical feed with integral controls. Closed loop systems shall have a manual bypass feeder system. All chemicals are to be recommended by the water-treatment system manufacturer. Chemicals shall be compatible with the piping system and components. A water analysis shall be performed to determine quality of water.

Any new equipment or piping needs to be pre-cleaned to remove the oils of manufacture, which can be accomplished with an alkaline phosphate cleaner supplied by the water treatment supplier. It is necessary that all valves and fan coil units in the system be opened to flow during the cleaning process. The cleaning process shall be as follows:

- All coils shall be bypassed for the first two hours of a flush and then opened to flow through the coils for the rest of the flush.
- System shall be filled with fresh water and then circulated with all process and booster pumps running.
- Alkaline phosphate detergent shall be added following the manufacturer's instructions concerning the correct dosage. It may be necessary to add de-foamer in some instances.
- System shall be circulated for a minimum of four hours, and hourly flushed all low-point drains to remove any suspended solids that may have been displaced.
- Upon completion of the cleaning, system shall be drained and refilled with fresh water. Fresh water shall be circulated for 20 minutes and then bled heavily until the water is clear and free of foam. Flushing shall continue until the ortho phosphate level is within 1 PPM of that of the city water and the conductivity is close to that of the make-up water. If the flushing occurs over an extended period in time (more than 24 hours), the flush water should be treated water.

- The system shall be immediately sterilized by maintaining a minimum of 1 PPM as free halogen for one hour and then treated to passivate the clean metallurgies. Systems containing copper should be treated with azole levels of 20 PPM as a minimum. Molybdenum should be used to passivate mild steel piping by achieving a minimum of 50 PPM. The recommended inhibitor levels must be maintained for 24 hours.

Systems that are having piping added that cannot be isolated for alkaline phosphate cleaning must have a surfactant added for 48 hours.

Systems that are having galvanized towers added must undergo a white rust passivation step for the first 90 days of operation.

Flushing and cleaning is allowed through new construction house pumps. Flushing and cleaning is not allowed through existing house pumps. It shall be the responsibility of the flushing and cleaning contractor to provide a pump sized properly for the system to be flushed.

Approved Manufacturers:

- a. Contact Facilities Operations for current campus vendor.

G. Cost-saving Alternatives

This section provides cost-saving alternatives for certain components of a project. The RED+F PM will advise the A/E Design Team if this section shall be used on their project. When so stipulated, the A/E Team shall follow the *NYU Langone Health – Design Guidelines* except the items below will be utilized for all affected components. There may be risks associated with using such items, including the need to repair or replace them more often, but it has been determined they are within acceptable range for use on certain NYU Langone Health projects.

#	Item	Type of Build-Out		
		Science / Clinical (Article 28)	Leased Science / FGP (Non-Article 28)	Admin / Office
1	Remove low pressure duct leakage testing.		✓	✓
2	Remove requirement for each coil to have a freeze stat in multiple coil units and only provide one long freezestat in all non-Article 28 spaces.		✓	✓
3	Allow triple duty valves in off-site locations.		✓	✓
4	Change pipe labeling from every 5 feet in concealed and 10 feet in unconcealed to 10 feet concealed and 20 feet unconcealed.		✓	✓
5	Change valve tags from metal to printed plastic in off-site locations only.		✓	✓

END OF MECHANICAL SUBSECTION

3. ELECTRICAL

A. Codes, Regulations and Design Standards.

- I. The installation will comply with applicable provisions of the New York State Building Code and New York City Electrical Code, Department of Health (DOH) standards, Centers for Medicare and Medicaid Services (CMS) standards and all other applicable Codes.

B. Design Criteria

- I. All connections to be done with double hole lugs (long barrel) and utilize compression type copper connectors. If this is not possible, the design scheme shall be discussed and approved by Facilities Operations.

II. Emergency Power

- a. Emergency Power shall be provided per NFPA Standards, Joint Commission Standards, CMS Standards and New York City Electrical Code requirements. Emergency power to be reviewed with Facilities Operations prior to design.

III. Design criteria for sizing power risers and (connected load) electric panels

- a. Administration/Office: 5.0 W/sq.ft.
- b. Clinical Office/Exam: 5.0 W/sq.ft.
- c. Storage: 1.5 W/sq.ft.
- d. Laboratories (Basic Research): 50 W/sq.ft.
- e. Support Areas: 12.5 W/sq.ft.
- f. Technology Rooms: 50 W/sq.ft.
- g. Procedure Rooms: 30 W/sq.ft.
- h. Specialty Rooms: 3 W/sq.ft.
- i. Offices: 6 W/sq.ft.
- j. Seminar and Classrooms: 4 W/sq.ft.
- k. Lobby: 6 W/sq.ft.
- l. Mechanical Rooms: 2.5 W/sq.ft. (Lighting and Small Power)
- m. Lounge/Waiting Area: 4 W/sq.ft.
- n. Café/Cafeteria: 15 W/sq.ft.
- o. Kitchen: 20 W/sq.ft.

IV. Lighting

- a. All lighting located outdoors, in mechanical, electrical, IT or other utility spaces, closets and storage spaces, stairwells, restrooms, and any space 16' above the finish floor and higher shall be LED type and shall be by a NYSERDA and/or ConEd rebate/incentive eligible manufacturer. All deviations must be reviewed on a case by case basis with Facilities Operations.

- b. All lamp sources shall be 3500K color temperature in non-patient care spaces, except where a different temperature is requested by end-users for clinical or technical reasons. Patient care areas will be evaluated on a case-by-case basis for color temperature and color rendering index.
 - c. In spaces where linear tubes are used, they shall be LEDs where possible and T-5 with high efficiency electronic ballasts in areas where LEDs are not possible for above listed reasons.
 - d. All other lamping should be LED or CFL. Incandescent lighting is acceptable in spaces with specialized requirements (ex. Research support spaces).
 - e. Emergency lighting shall be connected to Life Safety Emergency Power. Battery packs shall only be utilized for emergency generator rooms, emergency switchgear rooms, fuel oil rooms, ATS rooms, and at least one emergency light with battery pack in a procedure area where anesthesia is being administered.
 - f. 5% excess attic stock shall be provided for integrated, architectural LED fixtures (i.e. fixtures that need to be replaced entirely after failure).
- V. Distribution
- a. All power loads, such as elevators, motor control centers, etc., shall operate at 480/277 volts and shall be connected to distribution switchboards with single or multiple conduit and cable feeders.
 - b. Unless serving specialty equipment/lighting, receptacles as well as fluorescent and incandescent lighting shall be wired to 120 or 277 volt circuits.
 - c. All conduits shall be run concealed in finished areas and exposed in Machine Rooms and Electrical Rooms.
 - d. All lighting circuits shall emanate from lighting panels and power circuits from power panels. Lighting and Power circuits shall not be mixed in the same panel.

C. Electrical Naming Convention

COORDINATE NOMENCLATURE WITH NYU LANGONE ELECTRICAL SYSTEMS MANAGER
 PRIOR TO LABELING OR RE-LABELING ELECTRICAL EQUIPMENT DESIGNATIONS.

I. Generator Panel Naming Scheme

Example: PPH-G4-HCC-CE1

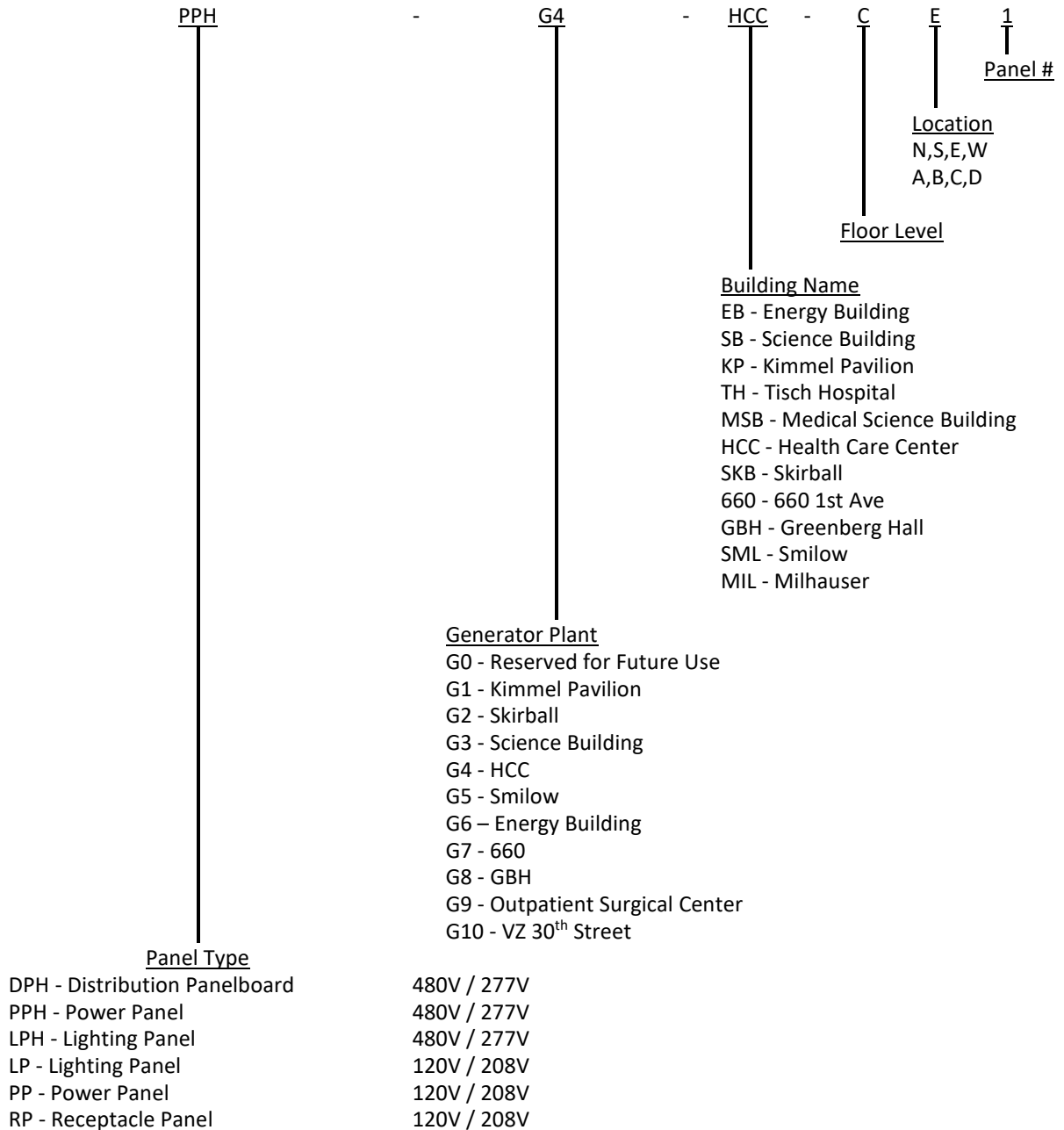

II. Normal Power Panel Naming Scheme

Example: SS-PES-HCC-CE1

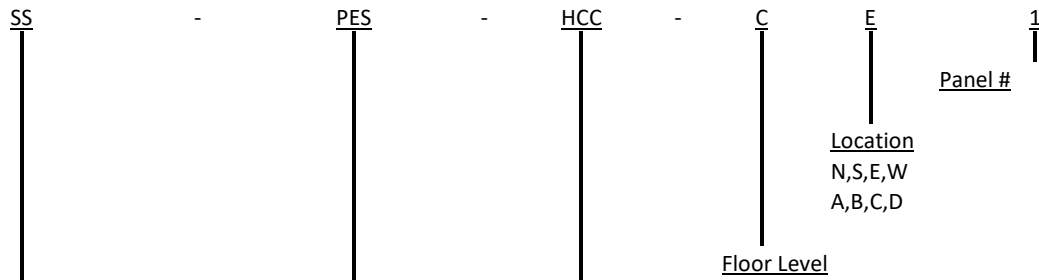

Building Name

- EB - Energy Building
- SB - Science Building
- KP - Kimmel Pavilion
- TH - Tisch Hospital
- MSB - Medical Science Building
- HCC - Health Care Center
- SKB - Skirball
- 660 - 660 1st Ave
- GBH - Greenberg Hall
- SML - Smilow
- MIL - Milhauser
- AMB- Ambulatory Surgery

Primary Electric Service

Normal Panel Type

SSH - Service Switchboard	460V / 265V
DPH - Distribution Panelboard	460V / 265V
LPH - Lighting Panel	460V / 265V
PPH - Power Panel	460V / 265V
SS - Service Switchboard	120V / 208V
DP - Distribution Panelboard	120V / 208V
LP - Lighting Panel	120V / 208V
PP - Power Panel	120V / 208V
RP - Receptacle Panel	120V / 208V
BD – Bus Duct	
DESS – Double Ended Substation	

III. UPS Naming Scheme

Example: TPP-2-G5-61-SML-M-B1

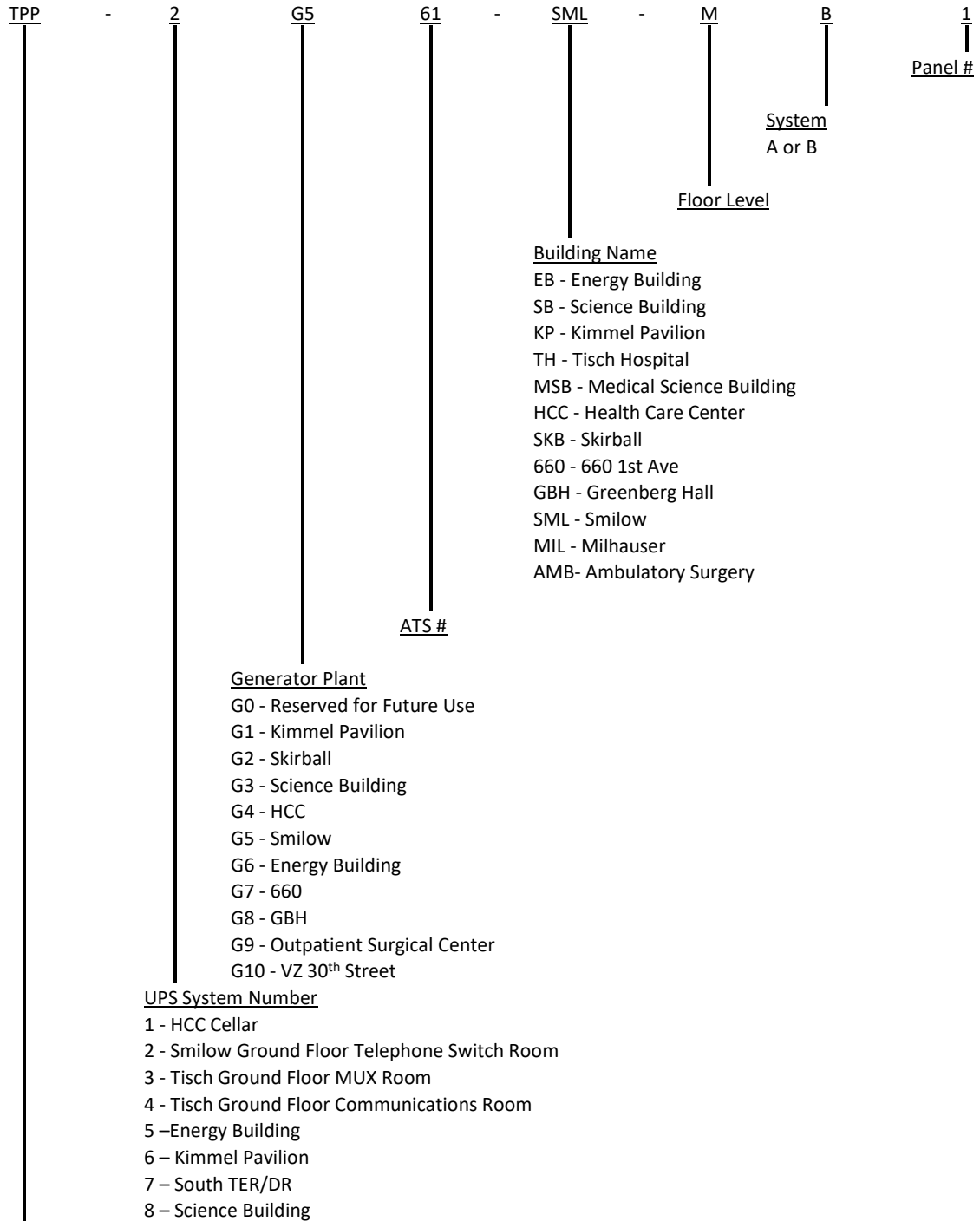

UPS Panel Types

- TDP - Technology Distribution Board – 120/280V
- TPP - Technology Power Panel – 120/280V
- TDPH – Technology Distribution Panel – 480/277V
- MDSH – Medical Distribution Switchboard – 480/277V
- MDPH – Medical Distribution Panel – 480/277V

IV. Emergency Panel Naming Scheme

Example: LS-PP-G4-61-HCC-CE1

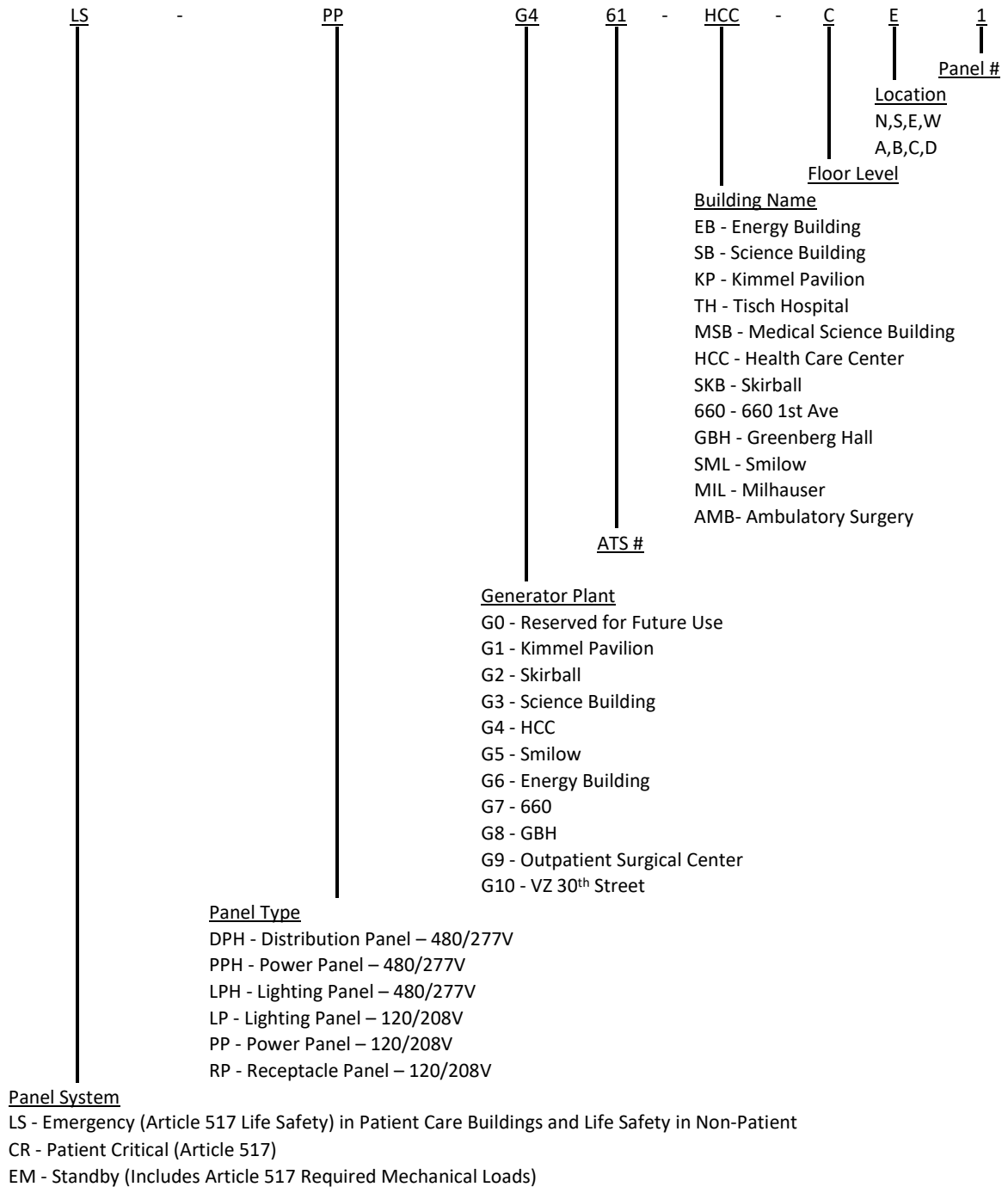

V. Bus Duct Naming Scheme

Example: BD-KP-CR-1B2

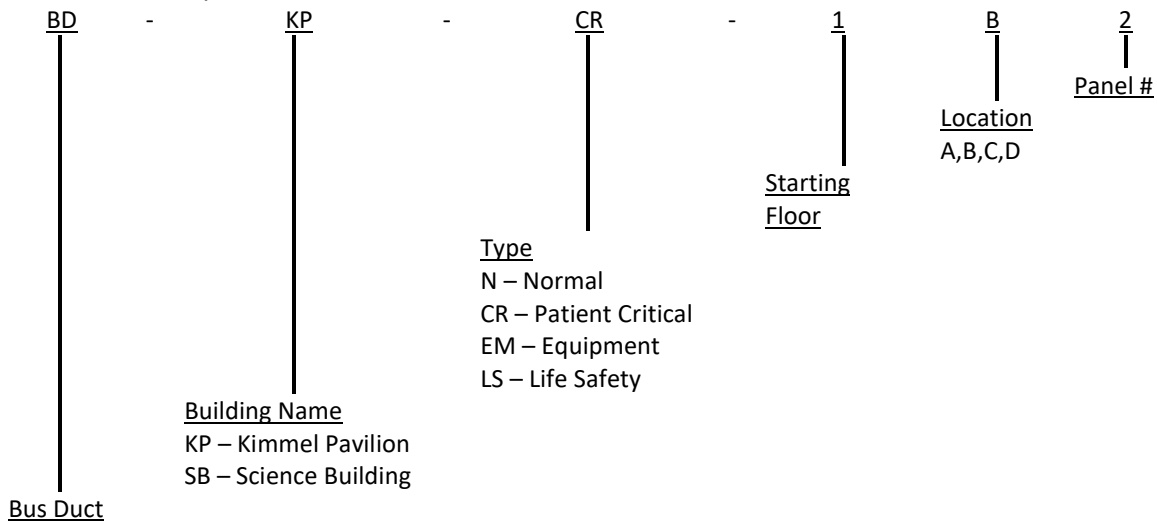

D. Various

- I. The following is a list of electrical gear that shall have heat runs/burn-ins performed prior to turnover. All burn ins/heat runs shall be at rated load (full load). Infrared scanning shall be provided during the entire burn time.
 - a. Uninterruptible Power Supply (UPS) – 12 hour burn in
 - b. Uninterruptible Power Supply Rack Type – 30 minute burn in
 - c. Automatic Transfer Switch (ATS) – 4 Hour Burn In
 - d. Static Transfer Switch (STS) – 12 hour Burn In
 - e. Generator – 12 hours
 - f. Power Conditioner – 8 hour burn in

- II. Factory Witness Tests -
 - a. The following equipment shall be factory witness tested. See individual equipment subsections for further information regarding required tests. Maximum of two people (not including manufacturer). FWT shall include lodging, meals and travel.
 - 1) Generators
 - 2) Medium Voltage Transformers
 - 3) Paralleling Gear
 - 4) Uninterruptable Power Supply
 - 5) Double Ended Substation
 - 6) Power Conditioner
 - 7) Static Transfer Switch
 - 8) Medium Voltage Switches
 - 9) Transformer 1,000 kVa or higher

- III. Proper wire color schemes shall be used for all panels.

- IV. Isolated Ground (IG) receptacles are not allowed. If project team deems IG receptacles are necessary, engineer to discuss with Facilities Management.
- V. All emergency power shall be in conduit.
- VI. All boxes (splice, pull, etc.) shall be labelled with source and load.
- VII. Follow/refer to the “Dos and Don’ts” section for additional Engineering guidelines.
- VIII. All grounding to building steel shall be exothermically welded.

E. Equipment

1. Automatic Transfer Switches

Depending on application, ATS shall be bypass isolation type with load shedding capabilities. This shall be reviewed with Facilities Operations. A full monitoring package on all phases, KW, Voltage and Amperage shall be designed.

All ATS connected to cogeneration shall be delayed transition type. Each ATS must include communication package that can communicate with sitewide CPMS. Each ATS must also allow for the acceptance of a permissive signal for retransfer to be received from the cogeneration plant.

Engineer to add specifications testing section:

- 4 hour full load burn in. One hour each for the following: Normal, Normal Bypass, Emergency, Emergency Bypass.
 - i. At 30 minute intervals, record voltage, frequency, load current.
 - ii. Provide resistive load bank and all necessary temporary cables and connections for full load test.
- Simulate Power Failure

Approved Manufacturers:

- a. Asco

2. Busway and Accessories

Approved Manufacturers:

- a. General Electric "Spectra Series"
- b. Siemens

3. Cable Pulling Lubricants

Cable pulling lubricant shall not be used on isolated power systems.

The following shall not be specified without approval from NYU Langone’s division of EH&S:

- Chemicals that are known (IARC group 1) or probable (IARC group 2a) human carcinogens.
- Hazardous substances listed in OSHA 1910 subpart Z.

- Products containing volatile organic compounds (VOCs) in excess of 50 grams/liter.
- Products whose Safety Data Sheet (SDS) rates health, fire and/or reactivity as exceeding “1” on a scale of 0 to 4.
- Products emitting strong odors.

Approved Manufacturers:

- a. American Polywater Corporation - Type "J"
- b. Electro Compound Company - "Poly-Ease" or "Y-ER Ease"
- c. Ideal Industries - "Wire Lube"

4. Cable Tray and Fittings

Approved Manufacturers:

- a. Atlas
- b. Burndy
- c. Cooper B-Line Systems
- d. M.P. Husky Corp.
- e. P-W Industries
- f. Legrand

5. Clocks

In procedure areas clocks shall be wireless, synchronized, digital, and power over Ethernet.

Approved Manufacturers:

- a. Sapling

6. Dry-type Transformers

Factory testing shall be provided on medium voltage transformers and shall be discussed with NYU Langone Facilities Management prior to completing specifications. Factory witness testing shall at a minimum meet NETA Standard for Acceptance Testing Specifications for Electrical Power Equipment and Systems.

Approved Manufacturers:

- a. General Electric
- b. Hammond Power Solutions
- c. Jefferson Magnetek
- d. Siemens
- e. Rex Transformers
- f. ABB

7. Electric Heating Cable Systems

Approved Manufacturers:

- a. Chromalox
- b. Raychem

8. Electrical Conductors, Copper, 600 Volt or Less
All shall be UL Listed.

Approved Manufacturers:

- a. American Insulated Wire
- b. General Cable/Cablec
- c. Prysmian
- d. Southwire

9. Electrical Metallic Tubing (EMT)
All shall be UL Listed.

Approved Manufacturers:

- a. Allied Tube & Conduit/Tyco
- b. Republic
- c. Robroy Industries
- d. Triangle
- e. Western
- f. Wheatland

10. Electronic Fluorescent Ballasts

Approved Manufacturers:

- a. Advance
- b. MagneTek
- c. Universal

11. Electronic Fluorescent Dimming Ballasts

Approved Manufacturers:

- a. Advance
- b. Lutron
- c. Universal

12. Electronic Dimming System

Approved Manufacturers:

- a. Lutron
- b. Wattstopper

13. Enclosed Switches

Approved Manufacturers:

- a. General Electric
- b. Siemens
- c. Square D

14. Exit Signs

Exit signs shall meet the NYC Energy Code wattage requirements

Approved Manufacturers:

- a. Philips Caliber Series Edge-Lit LED
- b. Encore

15. Fire Detection, Alarm and Communication

See Fire Alarm Guidelines

16. Flexible Metal Conduit

All shall be UL Listed.

Approved Manufacturers:

- a. AFC
- b. ALFLEX
- c. American Metal Molding
- d. Anaconda
- e. Cerro
- f. International Metal Hose

17. Flexible Metal Conduit Fittings

All shall be UL Listed.

Approved Manufacturers:

- a. Appleton
- b. Efcor
- c. Midwest
- d. OZ/Gedney
- e. Raco/Hubbell
- f. Steel City/Thomas & Betts

18. Fluorescent Lamps

See Design Criteria lighting subsection at the beginning of the Electrical Design Guidelines for further design information.

Approved Manufacturers:

- a. General Electric 3500°K. T-5

19. Fuses

Approved Manufacturers:

- a. Ferraz –Shawmut – Amp-Trap 2,000 with a fuse window
- b. Cooper Bussmann

20. Generator

If installing equipment on a roof, refer to Do's and Don'ts section for requirements.

Generators shall be provided with a generator monitoring system. Base building monitoring system is a Monico System.

Factory testing shall be discussed with NYU Langone Facilities Management prior to completing specifications. Factory witness testing shall at a minimum meet NFPA 37 and NFPA 110 Standards.

All new generators ordered for sites in NY, NJ and CT shall be EPA Tier 4.

Approved Manufacturers:

- a. Caterpillar
- b. Cummins
- c. Kinsley Kohler

21. Heat Trace

All outdoor piping containing fluid shall be heat traced. Heat trace shall be monitored by the building automation system. Heat trace shall turn on by main outdoor air temperature sensor. Alarm shall be sent to BMS when heat trace is to turn on but there is no current flow or heat trace monitoring panel shows there is an error. Heat trace shall not turn on via its own controller.

Approved Manufacturers:

- a. Nelson
- b. Raychem
- c. Chromalox

22. High Intensity Discharge Lamps

Not allowed.

23. LED Light Fixtures

See Design Criteria lighting subsection at the beginning of the Electrical Design Guidelines for further information. LED Fixtures to be approved on a project to project basis. All LED fixtures to be 3500K. Chipset must be Phillips.

Approved Manufacturers:

- a. General Electric
- b. Phillips (Tubes)
- c. RAB Lighting (Panels)

24. Lighting

- a. All lighting located outdoors, in mechanical, electrical, IT or other utility spaces, closets and storage spaces, stairwells, restrooms, and any space 16' above the finish floor and higher shall be LED type and shall be by a NYSERDA and/or ConEd

rebate/incentive eligible manufacturer. All deviations must be reviewed on a case by case basis with Facilities Operations.

- b. All lamp sources shall be 3500K color temperature in non-patient care spaces, except where a different temperature is requested by end-users for clinical or technical reasons. Patient care areas will be evaluated on a case-by-case basis for color temperature and color rendering index.
- c. In spaces where linear tubes are used, they shall be LEDs where possible and T-5 with high efficiency electronic ballasts in areas where LEDs are not possible for above listed reasons.
- d. All other lamping should be LED or CFL. Incandescent lighting is acceptable in spaces with specialized requirements (ex. Research support spaces).
- e. Emergency lighting shall be connected to Life Safety Emergency Power. Battery packs shall only be utilized for emergency generator rooms, emergency switchgear rooms, fuel oil rooms, ATS rooms, and at least one emergency light with battery pack in a procedure area where anesthesia is being administered.
- f. Ultrasonic sensors are not allowed in/near animal holding, animal procedure areas, corridors outside holding/procedure areas, or adjacent spaces. Only infrared type sensors are allowed in these spaces.

25. Lighting Controls

To be reviewed with Facilities. Lighting control networks shall reside on the MCIT network with interconnection to the BMS network. Coordinate with MCIT.

Approved Manufacturers:

- a. Lutron
- b. Wattstopper
- c. Legrand

26. Line Voltage Switches, Wall Plates, and Coverplates

Stainless steel finish plates shall be used in all patient areas. Hospital grade type shall be used in all areas of the facility (non-patient and patient areas)

Approved Manufacturers:

- a. Hubbell
- b. Legrand

27. Liquid-tight Flexible Metal Conduit

All shall be UL Listed.

Approved Manufacturers:

- a. American Brass Company
- b. Anaconda (Type “UA”)
- c. Electri-Flex Company

28. Liquid-tight Flexible Metal Conduit Fittings

All shall be UL Listed.

Approved Manufacturers:

- a. American Brass Company
- b. Midwest
- c. O.Z./Gedney

29. Motor Control Centers

Pilot lights shall be LED. Lamp test button shall be provided.

Approved Manufacturers:

- a. Allen Bradley
- b. General Electric
- c. Siemens

30. Motor Controllers Variable Speed (VFD)

Refer to Mechanical subsection Motor Controllers Variable Speed (VFD) for design requirements.

31. Multi-outlet Assemblies

Information Technology multi-outlet assemblies shall comply to NYU Langone Health IT Design Standards.

Approved Manufacturers:

- a. Legrand

32. Outlets and Boxes

Approved Manufacturers:

- a. Appleton Electric Company
- b. Midland Ross
- c. Raco
- d. Steel City/Thomas & Betts
- e. Thepitt

33. Overcurrent Protective Devices

All field adjustable breakers 100-750 amperes shall be secondary injection tested. All field adjustable breakers over 750 amperes shall be primary injection tested.

Approved Manufacturers:

- a. Eaton
- b. General Electric
- c. Square D
- d. Siemens

34. Panelboard

All panels shall have a local main breaker, double hinged door and a locking #47 key cover. Panels to have an arc-flash study performed and coordinated. Circuit breakers directories must be populated and accurate.

Approved Manufacturers:

- a. American Switchboard
- b. All-City Switchboard
- c. Atlas Switchboard
- d. Electrotech
- e. Lincoln Electric Co.

35. Receptacles

All receptacles shall be hospital grade and illuminated.

Receptacle coverplates shall be stainless steel finish plates with high quality stickers showing panel and breaker designation. Hospital grade type shall be used in all areas of the facility (non-patient and patient areas). Switched outlets shall have labeling on receptacle coverplate stating "Receptacle shuts off when no one present; plug in cellphones or laptops only."

Receptacles shall be consistent in orientation with ground facing upwards. In addition to any other code requirements, all receptacles that are accessible to the general public shall be tamper proof.

Normal Power color shall be gray, duplex and illuminated face. Emergency power shall be red, duplex and illuminated face. Emergency receptacles shall be located in main service electrical rooms, substation rooms, ATS rooms, emergency paralleling switchgear rooms, and fuel oil pump rooms. Duplex emergency receptacles shall be located next to each sump and ejector pit.

All receptacles must be GFCI type within 6 feet of sink.

Do not install outlets below a fire extinguisher, eye wash or safety shower.

Approved Manufacturers:

- a. Hubbell
- b. Legrand

36. Rigid Aluminum Conduit and Fittings

All shall be UL Listed.

Approved Manufacturers:

- a. Alcoa
- b. Anchor-Harvey
- c. Harvey
- d. Kaiser
- e. Reynolds

37. Rigid Nonmetallic Electrical Conduit and Fittings

All shall be UL Listed.

Approved Manufacturers:

- a. Carlon/Lamson & Sessions
- b. Certainteed
- c. Triangle

38. Rigid Steel Conduit and Fittings (exposed to the weather)

All shall be UL Listed. PVC coated rigid steel conduits allowed only in outdoor applications or chemical areas.

Approved Manufacturers:

- a. Ocal Inc.
- b. Occidental Coating Company
- c. Perma-Cote
- d. Robroy Industries "Plasti-Bond-Red"
- e. Triangle

39. Rigid Steel and Intermediate Metal Conduit

All shall be UL Listed.

Approved Manufacturers:

- a. Allied
- b. Republic
- c. Triangle
- d. Western
- e. Wheatland

40. Rigid Steel and Intermediate Metal Conduit Fittings

All shall be UL Listed.

Approved Manufacturers:

- a. Appleton
- b. Cooper Crouse-Hinds
- c. Efcor
- d. Midwest
- e. O.Z./Gedney
- f. Raco/Hubbell
- g. Spring City
- h. Steel City/Thomas & Betts
- i. Thomas & Betts

41. Service Switch Assemblies and Distribution Switchboards

Approved Manufacturers:

- a. American Switchboard
- b. All-City Switchboard
- c. Atlas Switchboard
- d. Electrotech
- e. Lincoln Electric Co.

42. Submetering and Power Quality Metering

When a metered feed to a building is removed or changed, the new electrical feed shall be similarly metered.

Approved Manufacturers:

- a. Siemens
- b. Ion/Schneider
- c. General Electric
- d. PQube
- e. Satec

43. System Identification

Equipment Labels shall conform to equipment nomenclature found within these design guidelines and shall be engraved plastic nameplates with a black surface and white core with engraved letters for normal power and red surface and white core for emergency power. Engraved lettering shall be a minimum of 2" in letter height for:

- Panels
- Disconnect switches
- Main Switch boards
- ATS
- Transformers
- UPS

Distribution branch circuits shall have ½” lettering.

Conduit and cable labelling identifying the circuit designation shall be every 5’ in concealed areas and 10’ in un-concealed areas.

Raceway identification color coding shall be provided as follows:		
Normal Power	White on Black	TEXT
Emergency Power, Fire Alarm, ATS/MTS	White on Red	TEXT
Life Safety Branch	White on Red	TEXT
Critical Branch	White on Blue	TEXT
Optional Standby Systems	White on Blue	TEXT
UPS	Black on Yellow	TEXT
BMS	Black on Orange	TEXT

44. Transient Voltage Surge Suppression

Surge suppression shall be integral to electrical panels located in IDF and BDF rooms.

Approved Manufacturers:

- a. Current Technology
- b. General Electric
- c. Liebert
- d. United Technologies

45. Type "AC" (Armored Cable) Conductor Cables, 600 Volts or Less

All shall be UL Listed. Armored Cable shall be hospital grade BX. In lieu of armored cable, metal clad (aluminum) is allowable.

Approved Manufacturers:

- a. AFC
- b. Alflex
- c. Southwire

46. Vibration Isolation Devices and Seismic Restraints

Approved Manufacturers:

- a. Amber/Booth Company
- b. Korfund Dynamics Corporation
- c. Mason Industries, Inc.
- d. Vibration Eliminator Company
- e. Vibration Mounting and Controls, Inc.

47. Wall Dimmers

Approved Manufacturers:

- a. Lutron
- b. Wattstopper

48. Wire Connectors and Lugs

All shall be UL Listed.

Approved Manufacturers:

- a. AMP
- b. Anderson/Hubbell
- c. Burndy
- d. Homac
- e. Ideal
- f. ITT-Blackburn
- g. MAC
- h. Thomas & Betts
- i. Tyco Electronics/AMP
- j. Union Connector Co.
- k. 3M

49. UPS (Central)

Factory testing shall be discussed with NYU Langone Facilities Management prior to completing specifications. Factory witness testing shall at a minimum meet NETA Standard for Acceptance Testing Specifications for Electrical Power Equipment and Systems.

UPS shall have webserver capabilities to login (with credentials) to view all operating characteristics of unit. This link shall be integrated within the BMS.

Provide power conditioners for sensitive medical imaging (MRI, LINAC, etc.)

Approved Manufacturers:

- a. Liebert (data equipment only)
- b. Mitsubishi (medical equipment only)

50. UPS (Rack Mounted)

Refer to IT design guidelines.

F. Cost-saving Alternatives

This section provides cost-saving alternatives for certain components of a project. The RED+F PM will advise the A/E Design Team if this section shall be used on their project. When so stipulated, the A/E Team shall follow the *NYU Langone Health – Design Guidelines* except the items below will be utilized for all affected components. There may be risks associated with using such items, including the need to repair or replace them more often, but it has been determined they are within acceptable range for use on certain NYU Langone Health projects.

#	Item	Type of Build-Out		
		Science / Clinical (Article 28)	Leased Science / FGP (Non-Article 28)	Admin / Office
1	Remove bypass from Automatic Transfer Switch for off-site locations.		✓	✓
2	Change conduit labeling from every 5 feet in concealed and 10 feet in unconcealed to 10 feet concealed and 20 feet unconcealed.		✓	✓

END OF ELECTRICAL SUBSECTION

4. **PLUMBING**

A. Codes, Regulations and Design Standards.

The entire installation shall comply with the City of New York Building Codes, NYC Department of Health, Department of Environmental Protection Agency, and all other applicable local Codes.

B. Design Criteria

- I. Domestic Hot Water Plant Temperature shall be: 140°F in Kimmel Pavilion, all other spaces shall be 120°F.
- II. Patient room maximum domestic water temperature shall be: 110°F.
- III. Plumbing fixtures shall be of high efficiency conserving type to comply with the City of New York Water Conservation requirements.
- IV. All domestic water piping shall be type “L” copper, unless otherwise dictated by code.
- V. Point of use mixing valves shall be provided under all lavatories, hand sinks, pantry sinks and similar fixtures where required by code.
- VI. Pressure at fixtures shall be designed to provide a maximum of 85 psi.
- VII. Pressure reducing valves shall be installed wherever the water pressure exceeds 85 psi.
- VIII. The piping shall be sized to provide a maximum velocity of 6 feet per second (fps) in the mains, and 4 fps in all branch piping.
- IX. Hose bibs with $\frac{3}{4}$ inch male hose threads and vacuum breaker shall be provided in all mechanical spaces.
- X. Mechanical rooms and water service rooms shall be provided with floor drains and waterless trap seals (Liquid Breaker Green Drain).
- XI. All sanitary, vent and storm drainage piping above the design flood elevation (DFE) shall be hubless cast iron pipe with heavy-duty couplings or hub and spigot piping with push-on gaskets. Piping 4” and less shall be hubless, 5” and greater shall be hub and spigot. All piping within cellars shall be hub and spigot.
- XII. Storm piping, sump discharge piping and ejector discharge piping located below the design flood elevation shall be grooved, schedule 40 galvanized steel pipe with mechanical couplings. Alternative materials shall be used for sump discharge piping where dictated by ground water quality.

- XIII. All sanitary, vent and storm drainage piping buried below slab, draining to an ejector or sump pit shall be extra heavy hub and spigot cast iron with push on gaskets.
- XIV. All sanitary, vent, and storm piping below the design flood elevation (DFE) shall be ductile iron with mechanical couplings.
- XV. All natural gas piping with gas pressures $\frac{1}{2}$ psig and less shall be schedule 40 steel piping with threaded fittings for sizes up to and including 3 inches and natural gas piping larger than 3 inches shall be schedule 40 piping with welded joints.
- XVI. All natural gas piping with gas pressures greater than $\frac{1}{2}$ psig shall be schedule 40 steel piping with welded joints.
- XVII. All medical gas piping and vacuum piping shall be brazed.
- XVIII. Medical fittings, valves and piping shall come cleaned and flushed in sealed packaging from the manufacturer.
- XIX. Polypropylene piping shall be mechanically joined with coupling and additional restraints shall be provided at all offsets. Fused joints shall not be used.
- XX. Hydronic systems with bottom of system make-ups must have a manual make-up connection RPZ/backflow preventer at the top of the system as a backup.
- XXI. Brass caps shall be provided on all drain lines.
- XXII. Medical gas takeoffs from riser shall be full size throughout floor loop. The piping size shall not be reduced on a floor loop. Takeoffs from floor loops shall be sized adequately.
- XXIII. Follow/refer to the “Dos and Don’ts” section for additional Engineering guidelines.
- XXIV. All domestic water recirculating lines shall be balanced by a certified testing and balancing contractor.

C. Equipment

1. Acid Neutralization

Systems shall be centralized and comprised of sediment tank, pre-treatment tank (no limestone), chemical injection tank and sampling tank in compliance with DEP standards.

Approved Manufacturers:

- a. Town and Country

2. Backflow Preventers
Approved Manufacturers:
 - a. Watts
 - b. Febco

3. Baseboard Radiation (Steam/Water)
See Mechanical subsection

4. Drains
Weep hole drains are not allowed unless liners are designed as part of the system and installed as such.

Approved Manufacturers:
 - a. Josam
 - b. JR Smith
 - c. Zurn

5. Electric Water Coolers
Approved Manufacturers:
 - a. Elkay
 - b. Filtrine
 - c. Halsey Taylor

6. Fixture Supports
Approved Manufacturers:
 - a. Jay R. Smith
 - b. Josam
 - c. Wade
 - d. Zurn

7. Flow Measuring Devices
A positive displacement meter shall be installed for domestic water systems if one is required. Status of meter and flowrate shall be monitored on the building management system. Confirm with NYULH facilities with meter manufacturer.

8. Gauges and Thermometers
Temperature Scale Ranges:
 - Domestic Hot Water Piping: 20 to 250 deg F
 - Steam-Condensate Piping: 0 to 250 deg F
 - Steam Piping: 212 to 250 deg F
Compound gauges shall be used on suction side of pumps when required due to system pressure. Digital Vari-Angle Thermometers (Digital-Solar) to be used in place of Liquid-In-Glass type.

Pressure Scale Ranges:
Design engineer shall specify proper scales based on operating pressures.

Switches, thermometers, meters, gauges and other components shall be mercury-free in compliance with NYU Langone Health’s Mercury Elimination Program.

Approved Manufacturers:

- a. Instrument Test Ports
 - 1) Peterson Equipment
 - 2) Watts Regulator

- b. Pressure Gauges 1.00% Accuracy
 - 1) Ashcroft
 - 2) Trerice
 - 3) Weiss
 - 4) Weksler

- c. Pressure Switches
 - 1) Barksdale
 - 2) Dwyer
 - 3) Mercoid
 - 4) Square D

- d. Thermometers 1.00% Accuracy
 - 1) Trerice
 - 2) Weiss
 - 3) Weksler

9. Hot Water Heaters

Approved Manufacturers:

- a. Patterson-Kelley Company
- b. A.O. Smith

10. Insulation

Piping insulation shall comply with latest codes and energy conservation codes.

Approved Manufacturers:

- a. Armacell
- b. Armstrong
- c. Knauf
- d. Johns-Manville
- e. Owens-Corning Fiberglas (O-C-F)
- f. P.P.G. (Pittsburgh Plate Glass)

11. Medical Air Compressors

Compressors shall be oil-less reciprocating compressors and compliant with the latest NFPA-99 standards.

Approved Manufacturers:

- a. Beacon-Medaes

12. Medical Gas Equipment

Approved Manufacturers:

- a. Beacon-Medaes

13. Medical Gas Outlets

Outlets shall be DISS type, having a minimum pig tail connection point of ½” for all services. Vacuum and WAGD piping shall drop individually to each outlet. Header piping shall be readily accessible and shall be a minimum of 1”.

Approved Manufacturers:

- a. Beacon-Medaes made by Hill Rom

14. Motors

Conform to NEMA MG 1. Motors shall not operate continuously at a service factor greater than 1. Design to a service factor of a minimum of 1.15. Provide hoist type access for maintenance purposes.

Motors to be with permanently greased bearings (preferred). If permanently greased bearings are not provided, grease ports shall be provided with adequate access – grease capillaries are not allowed.

Bearings shall have a life grade of L5 with a minimum of 50,000 hours.

Approved Manufacturers:

- a. Standard Efficiency (Less Than 1 hp)
 - 1) Baldor
 - 2) General Electric
 - 3) Toshiba
 - 4) U.S. Motors
 - 5) Dayton
 - 6) Marathon
 - 7) Weg

- b. Premium Efficiency (1 hp and Above)
 - 1) Baldor
 - 2) General Electric
 - 3) Toshiba
 - 4) U.S. Motors
 - 5) Dayton
 - 6) Marathon
 - 7) Weg

15. Motor Starters

Approved Manufacturers:

- a. Asea Brown Boveri (ABB)
- b. ASCO
- c. Allen Bradley
- d. Siemens
- e. Yaskawa Electric America

16. Motor Controllers Variable Speed (VFD)

VFDs and VFD bypass shall be reviewed and approved by Facilities Operations.

Approved Manufacturers:

- a. Asea Brown Boveri (ABB)
- b. General Electric
- c. Toshiba
- d. Yaskawa Electric America

17. Orifice Steam Traps (Venturi Orifice Type)

Steam traps to have unions upstream and downstream of traps.

Approved Manufacturers:

- a. Steam Gard

18. Pipe and Fittings

Dielectric fittings shall be installed between all dissimilar metals. Piping ball joints for movement between buildings shall be flanged and not welded.

Steam pipe gaskets are to be solid graphite type (Equalseal EQ FG-P). Spiral wound gaskets will not be accepted.

Clamp free acid waste piping allowable only under a sink where piping ties into the trap.

Approved Manufacturers:

- a. Gaskets
 - 1) Garlock
 - 2) Flexitallic
 - 3) Lamons
 - 4) Equalseal EQ FG-P (All Steam Piping shall be this type.)

19. Pipe Hangers and Supports

All exposed threaded rods shall be capped with an orange protective cap either rubber or plastic. All threaded rods shall be cut down to an inch of final nut – rods shall not be left at full length for safety reasons. All components shall be galvanized or red-oxide coated.

20. Pipe Joint Compound

The following shall not be specified without approval from NYU Langone’s division of EH&S:

- Chemicals that are known (IARC group 1) or probable (IARC group 2a) human carcinogens.
- Hazardous substances listed in OSHA 1910 subpart Z.
- Products containing volatile organic compounds (VOCs) in excess of 50 grams/liter.
- Products whose Safety Data Sheet (SDS) rates health, fire and/or reactivity as exceeding “1” on a scale of 0 to 4.
- Products emitting strong odors.

Approved Manufacturers:

- a. LACO
- b. Rector-Seal
- c. Hercules

21. Plumbing Fixtures

Approved Manufacturers:

- a. American Standard
- b. Kohler
- c. Toto
- d. Zurn
- e. Elkay
- f. Moen
- g. Sloan
- h. Bradley
- i. Just Mfg.
- j. Chicago Faucets
- k. T&S Brassworks

22. Purified Water System Equipment (Reverse Osmosis and Deionized Systems)

Approved Manufacturers:

- a. Hydro (except for dialysis)
- b. Evoqua

23. Safety Showers/Eyewashes

Eyewash stations shall be manual hand type. Showers shall be ball valve pull type.

Approved Manufacturers:

- a. Guardian Equipment
- b. WaterSaver Faucet Co.

24. Seismic Restraints

Approved Manufacturers:

- a. Mason Industries
- b. Tolco

25. Sump Pumps and Ejectors

Pumps shall be provided with hoisting capabilities within area of equipment. There shall be a hook in the ceiling slab or rail system.

Switches, thermometers, meters, gauges and other components shall be mercury-free in compliance with NYU Langone Health's Mercury Elimination Program.

Approved Manufacturers:

- a. Flygt
- b. Tsunami
- c. Gorman Rupp

26. System Identification

Refer to Mechanical system identification for requirements

27. Toilet Seats

Approved Manufacturers:

- a. Church
- b. Olsonite

28. Vacuum Pumps

Approved Manufacturers:

- a. Beacon Medaes
- b. Nash
- c. Camel

29. Valves

Dielectric fittings shall be installed between all dissimilar metals. All mixing valves shall be installed with check-valves on the hot and cold water lines.

Ball valves must be used for manual isolation on all domestic hot and cold water systems. Butterfly valves shall be reviewed by Facilities Operations. Gate valves are not permitted unless specifically required by codes or DEP.

All valves used in plumbing systems shall close bubble tight and be suitable for dead-end service designed to be able to close off to atmospheric pressure on either side of valve.

All valves located more than 7 feet above the finished floor, shall be provided with a chain wheel for operation from the floor. All fire protection valves installed 7 feet above floor or stair landing shall be provided with chain wheels and shall be padlocked securely in place.

All valves 4" and larger shall be stainless steel or all hot and cold water.

Ball valves shall be installed on piping up to 3" in size. Butterfly valves shall be installed on piping 4" and above.

Approved Manufacturers:

- a. Ball Valves
 - 1) Apollo
 - 2) Nibco
- b. Butterfly Valves
 - 1) Apollo
- c. Pressure Relief Valves
Provide at each pressurized water vessel and as required by Code. Relief valves shall meet the maximum allowable working pressure of piece of equipment for which it is installed. Relief valve piping shall be full sized according to outlet size of relief valve and shall be piped to the floor. Steam relief vents shall be piped to atmosphere.
 - 1) Apollo
 - 2) Febco
 - 3) Watts
 - 4) Aquatrol series 69 (water)
 - 5) Aquatrol series 740 (steam)
- d. Temperature Mixing Valves (under sink)
 - 1) Leonard
 - 2) Powers
 - 3) Holby
 - 4) Watts
- e. Master Mixing Stations
 - 1) Holby

30. Water Supply Pumps

All pumps shall be provided with premium efficiency motors. Pumps shall not be provided with triple-duty valves unless install restrictions require such an install. If triple-duty valves are required, they shall be reviewed and approved by Facilities Operations. Butterfly valves shall not be used on the pump suction.

Piping and pumps shall be independently supported. All piping within 50 feet of pump shall be supported with hangers having spring type isolators.

Install pumps in such a way to allow periodic maintenance, which includes removal of motors, impellers and couplings. Pumps are required to be able to be drained down.

Bearings shall have a life grade of L5 with a minimum of 50,000 hours.

Provide hoist type access for maintenance purposes.

Approved Manufacturers:

- a. Armstrong
- b. Aurora
- c. Bell & Gossett
- d. Gould
- e. Peerless
- f. Weinman
- g. US Pump Corp

D. Cost-saving Alternatives

This section provides cost-saving alternatives for certain components of a project. The RED+F PM will advise the A/E Design Team if this section shall be used on their project. When so stipulated, the A/E Team shall follow the *NYU Langone Health – Design Guidelines* except the items below will be utilized for all affected components. There may be risks associated with using such items, including the need to repair or replace them more often, but it has been determined they are within acceptable range for use on certain NYU Langone Health projects.

#	Item	Type of Build-Out		
		Science / Clinical (Article 28)	Leased Science / FGP (Non-Article 28)	Admin / Office
1	Change pipe labeling from every 5 feet in concealed and 10 feet in unconcealed to 10 feet concealed and 20 feet unconcealed.		✓	✓
2	Change valve tags from metal to printed plastic in off-site locations only.		✓	✓

END OF PLUMBING SUBSECTION

5. FIRE PROTECTION

A. Codes, Regulations and Design Standards.

The entire installation shall comply with the current City of New York Building Codes, NFPA, NYC Fire Department, Factory Mutual Global Insurance or another insurance underwriter and all other applicable local Codes.

Architectural and Engineering construction drawings shall specifically state that fire protection systems (standpipe, sprinkler and fire alarm/detection systems) and construction partitions during construction shall comply with the following:

All projects:

- The contractor shall provide the required fire watch for the duration of any fire protection system or rated construction partition impairment.
- NYULH safety policy 120 - Construction Safety Requirements
- NFPA 13 - Standard for the Installation of Sprinkler Systems
- NFPA 72 - National Fire Alarm and Signaling Code

Projects in New York City:

- Building Code Chapter 33 – Safeguards during Construction or Demolition
- Department of Buildings Technical Bulletin 2017-009 (or superseding bulletin)
- Fire Code Chapter 14 – Fire Safety during Construction, Alteration and Demolition

Projects in New York State:

- Building Code Chapter 33 – Safeguards during Construction
- Fire Code Chapter 33 – Fire Safety during Construction and Demolition

Healthcare and Ambulatory Care occupancies:

- NFPA 101 - Life Safety Code
- NFPA 241 – Standard for Safeguarding Construction, Alteration and Demolition Operations

B. Design Criteria

- I. Buildouts shall be provided with full sprinkler protection and sprinkler systems shall be hydraulically calculated in accordance with the current City of New York Building Code and NYC Fire Department requirements.
- II. Fire department standpipe connections shall be provided with a 2-1/2 fire hose valve and hose rack on every landing of every required stairway.
- III. Areas without ceilings (storage, mechanical spaces, etc.) shall utilize upright sprinkler heads.
- IV. Areas with suspended ceilings (back of house areas, bathrooms, offices, etc.) shall utilize concealed sprinkler heads.

- V. Areas subject to freezing shall utilize a dry pipe sprinkler system with upright sprinkler heads.
- VI. Fuel Oil storage rooms shall be protected with a wet type foam sprinkler system or as reviewed and approved by Facilities Operations.
- VII. New and retro-fitted sprinkler systems shall have at least a 1-1/2" valve connection for draining.
- VIII. Electrical Closets shall be provided with wet side wall sprinkler heads each with protective cages.
- IX. Elevator machine rooms that fall under DOH jurisdiction shall be protected by alternate means of fire suppression. This shall apply to new construction or major overhaul.
- X. System types (wet, dry, preaction, foam, alternatives) must be reviewed with NYU Langone project managers and also with Facilities Operations during design development.
- XI. Pre-Action systems shall be installed in X-Ray, Gamma Knife, LINAC and any other similar sensitive equipment rooms.
- XII. Flexible sprinkler connections are allowed to be used in non-New York City projects where applicable by code. Hoses shall be braided stainless steel with proper pressure rating. The flexible sprinkler connection shall be used in conjunction with an approved manufacturer ceiling mounting bracket. Mounting brackets shall be attached to a ceiling's main tee bar support and not cross support rail members. Care shall be taken to prevent unnecessary movement which can dislodge ceiling mounting bracket when sprinkler is discharging. This may include supporting flexible sprinkler connection to building structure independent of the ceiling suspension and support system.
- XIII. Follow/refer to the "Dos and Don'ts" section for additional Engineering guidelines.
- XIV. Specify "Stat-X" for article 28 elevator machine rooms in article 28 spaces in NYC.
- XV. Side wall sprinkler heads are preferred in IDF and BDF technology rooms.

C. Equipment

1. Anchors and Inserts

Approved Manufacturers:

- a. Grinnell
- b. Hilti
- c. Philips
- d. Simpson Strong Tie

2. Motor Starters

Approved Manufacturers:

- a. Allen Bradley
- b. ASCO
- c. General Electric
- d. Gould Westinghouse

3. Motors

Approved Manufacturers:

- a. Baldor
- b. General Electric
- c. Toshiba
- d. U.S. Electric

4. Pipe Hangers and Supports

All exposed threaded rods shall be capped with an orange protective cap either rubber or plastic. All threaded rods shall be cut down to an inch of final nut – rods shall not be left at full length for safety reasons. All components shall be galvanized or red-oxide coated.

5. Piping

Piping shall be painted per building codes. Piping up to flow control assemblies shall be painted red.

Approved Manufacturers:

- a. Flanges
 - 1) Grinnell
 - 2) Ladish
 - 3) National Flange
 - 4) Taylor Forge
 - 5) Weld Bend
- b. Screwed Fittings
 - 1) Central
 - 2) Grinnell
 - 3) Ward

6. Preaction Control Panel/Equipment
Pre-action systems shall be addressable.

Approved Manufacturers:

- a. Simplex
- b. Notifier
- c. Kidde Fire Systems

7. Preaction/Dry Pipe Valves
Approved Manufacturers:

- a. Reliable
- b. Viking
- c. Victaulic

8. Pressure-Reducing Valves
Approved Manufacturers:

- a. Cla-Val
- b. Watts

9. Pumps

Approved Manufacturers:

- a. Fire Pump Controllers
 - 1) ASCO/Firetrol
 - 2) Joslyn-Clark
 - 3) Hubbell (mercury-free options)
- b. Fire Pump Controller Automatic Transfer Switch
 - 1) ASCO/Firetrol
 - 2) Eaton
 - 3) Russelectric
- c. Fire Pumps
 - 1) Aurora
 - 2) Patterson
 - 3) Peerless
- d. Jockey Pumps
 - 1) Aurora
 - 2) Groundfos
 - 3) Peerless

10. Standpipe System Equipment

(Siamese, fire hose valves, fire hose cabinets, and racks, etc.)

Approved Manufacturers:

- a. Badger-Powhattan
- b. Croker
- c. Elkhart
- d. Potter-Roemer

11. Seismic Restraints

Approved Manufacturers:

- a. Mason Industries
- b. Tolco

12. Sprinkler Heads, Valves, Alarms, Etc.

Approved Manufacturers:

- a. Grinnell
- b. Reliable
- c. Viking

13. System Identification

Equipment Labels shall be high quality stickers.

Pipe Labels shall be installed every 5 feet in concealed areas and every 10 feet in un-concealed areas and shall be self-adhesive labels with direction-of-flow arrows and the name of the service printed in black letters not less than 1 inch high for pipe 2-1/2 inches and smaller, 2 inches high for 3 inch pipe and larger. Markers shall have backgrounds of different colors for the various service groups. Pipe labels shall be color coded per ASME A13.1).

Valve Tags: Each valve tag shall be 3 in diameter, brass, aluminum or stainless steel with letters 2in in height. A schedule showing all valve locations, size, and service shall be provided.

Specify in specifications to post laminated valve tag schedules in space.

Approved Manufacturers:

- a. Brimar Industries Incorporated
- b. Seton Nameplate Corp.
- c. W. H. Brady Co.

14. Tamper Switches

Approved Manufacturers:

- a. Acme
- b. Grinnell
- c. Potter (mercury-free options)
- d. System Sensor (mercury-free options)
- e. Viking

15. Valves

Approved Manufacturers:

- a. Butterfly Valves
 - 1) Grinnell
 - 2) Jamesbury
 - 3) Jenkins
 - 4) NIBCO
 - 5) Victaulic
- b. Check Valves
 - 1) Crane
 - 2) Grinnell
 - 3) Kennedy
 - 4) Mueller
 - 5) NIBCO
 - 6) Victaulic
- c. Gate Valves
 - 1) Crane
 - 2) Grinnell
 - 3) Jenkins
 - 4) Kennedy
 - 5) NIBCO
 - 6) Walworth

16. Vibration Isolators

Approved Manufacturers:

- a. Amber Booth
- b. Korfund Dynamics Corp.
- c. Mason Industries
- d. Vibration Eliminator Co.
- e. Vibration Mountings & Controls

17. Water Flow Switches

Approved Manufacturers:

- a. Potter Electric Signal Company (mercury-free options)
- b. System Sensor

18. Water Proof Sleeves

Approved Manufacturers:

- a. Thunderline Corp. “Link Seal”

D. Cost Saving Alternatives

This section provides cost-saving alternatives for certain components of a project. The RED+F PM will advise the A/E Design Team if this section shall be used on their project. When so stipulated, the A/E Team shall follow the *NYU Langone Health – Design Guidelines* except the items below will be utilized for all affected components. There may be risks associated with using such items, including the need to repair or replace them more often, but it has been determined they are within acceptable range for use on certain NYU Langone Health projects.

#	Item	Type of Build-Out		
		Science / Clinical (Article 28)	Leased Science / FGP (Non-Article 28)	Admin / Office
1	Change pipe labeling from every 5 feet in concealed and 10 feet in unconcealed to 10 feet concealed and 20 feet unconcealed.		✓	✓
2	Change valve tags from metal to printed plastic in off-site locations only.		✓	✓

END OF FIRE PROTECTION SUBSECTION

6. **FIRE ALARM**

A. Codes, Regulations and Design Standards.

The entire installation shall comply with the current City of New York Building Codes, NFPA, NYC Fire Department, and all other applicable local Codes.

B. Design Criteria

I. The following buildings have their separate respective EST3 fire alarm systems:

- a. Tisch Hospital
- b. Smilow Research Center
- c. Medical Science Building/Alumni Hall and Coles
- d. Schwartz Health Care Center
- e. 660 First Avenue
- f. 545 First Avenue

II. All audibles and strobes shall be synced.

III. Chimes shall be installed in all sensitive areas in lieu of tones/horns. Sensitive areas include Operating Rooms, NICU, Anesthesiology, and Pre-Surgical. Contact Facilities Operations prior to designing in sensitive areas. Contractor shall obtain waiver if chimes are used in lieu of tones/horns.

IV. For Operating Rooms:

- a. During a detected fire/smoke alarm, only the fan/unit serving the Operating Room which the alarm was generated at shall shut down. All other operating room fans shall stay operational. For central AHU systems a variance is required to be filed with the FDNY and DOB and shall be reviewed with Facilities Operations prior to design.

V. Newly installed smoke heads shall stay covered until completion of project. No more than 20% dirty heads shall be accepted upon project completion.

VI. Follow/refer to the “Dos and Don’ts” section for additional Engineering guidelines.

C. Equipment

1. Fire Alarm System

Approved Manufacturers (no substitutes):

- a. Edwards – EST3 (Manhattan Superblock)
- b. (Brooklyn Campus) – Contact Brooklyn Facilities
- c. (Long Island Campus) – Contact Long Island Facilities
- d. Contact Real Estate & Housing Group for all off site locations for manufacturer

2. Heat Detectors

Approved Manufacturers (applies to Manhattan superblock campus; no substitutes):

- a. Edwards EST SIGA2-HFS

3. Strobe/Speaker
Approved Manufacturers (applies to Manhattan superblock campus; no substitutes):
 - a. Wheelock LSPSTR Series

4. Strobe/Horn
Approved Manufacturers (applies to Manhattan superblock campus; no substitutes):
 - a. Wheelock LHSR Series

5. Strobe
Approved Manufacturers (applies to Manhattan superblock campus; no substitutes):
 - a. Wheelock LSTR Series

6. Smoke Detector
Approved Manufacturers (applies to Manhattan superblock campus; no substitutes):
 - a. Edwards EST SIGA-OSD

7. Duct Detector
Above ceiling devices shall have separate LED indication and test buttons with magnetic test switch.

Approved Manufacturers (applies to Manhattan superblock campus; no substitutes):
 - a. Edwards EST SIGA-SDH

8. Manual Pull Station
Approved Manufacturers (applies to Manhattan superblock campus; no substitutes):
 - a. Edwards EST 270 Series

9. Aspirating Smoke Detection Systems
Aspirating Smoke Detection Systems shall be installed in all Mechanical and Electrical rooms that have ceilings above 10 feet or where conduits/ductwork/equipment/etc. will prevent maintenance of smoke detector heads.

Approved Manufacturers:
 - a. VESDA

END OF FIRE ALARM SUBSECTION

7. **BUILDING MANAGEMENT SYSTEM**

A. Codes, Regulations and Design Standards

The entire installation shall comply with the current City of New York Building Codes, NFPA, NYC Department of Fire, Department of Environmental Protection Agency and all other applicable local Codes. For properties located outside of the City of New York, the entire installation shall comply with all applicable local codes and standards.

B. General Requirements and Policy

i. General

- For renovation work in existing buildings, the existing manufacturer shall be used. For example, the Kimmel Pavilion in the Main Campus is served by an Automated Logic Corporation system. Any modifications to the existing control system shall utilize Automated Logic Corporation controllers.
- All controllers, sensors, field devices, etc., shall be UL-listed. Control units shall be listed for UL - 916 Energy Management Equipment.

ii. Engineering

- Design engineer shall provide a Network Riser as part of their design documentation. The Design Engineer shall not rely on the BMS contractor to create this.
- Ensure BMS sequences of operation align with control sensors indicated on single line drawings.
- Ensure BMS network is not on the IT network.
- AHU control devices shall be located outside of the airstream. Do not mount inside unit.
- All new BAS installations shall utilize IP based local controllers.
- For all systems that leverage both water and air to maintain climate control, always use water to achieve setpoints prior to additional use of air beyond minimum.
 - Minimum airflow determined by ventilation and/or pressurization requirements.

iii. IP/IT Security

- For details on policy for IP/IT security, reference the NYU Langone Health Critical Infrastructure Operational Technology (CIOT) Vendor Managed Device Standard.
- For sites with existing BMS's on the MCIT network, the BMS can remain on the MCIT network. For new sites installing a BMS, the BMS network should be stand alone and not part of the MCIT network.

iv. BMS Governance for Locations Not Owned by NYULH

For NYULH locations not owned by NYULH (landlord locations):

- Equipment owned and operated by NYULH shall be connected to the NYULH BMS. If an NYULH BMS does not exist, it shall be installed.
- Equipment owned and operated by the landlord shall remain on the landlord's BMS.
- Under no circumstances shall a project connect NYULH maintained equipment to an existing landlord BMS network.

v. Factory Acceptance/Witness Test

Factory tests are required for new BMS Panels installs, Panels shall be reviewed and graphics/sequences tested at controls factory prior to shipment, this only applies to large equipment and systems.

vi. Decommissioning and Demolition

General

- For any decommissioning and demolition worked performed on the NYULH Manhattan main campus, the engineer and project team shall follow the “NYULH Manhattan Campus BMS Controller Removal From Field and Database document. Obtain for Manhattan main campus facilities group.
- The following items must be included within the “General Scope of Work” section of the Contract Documents:
 - As existing mechanical and electrical systems are demolished and replaced with new systems, the existing control system serving the demolished equipment must also be removed from the BMS, in its entirety, inclusive of all field devices, controllers, wiring and server-related programming (i.e., graphics, trends, alarms, database, etc.)
 - The BATC Contractor is responsible for removing all items described below. Failure to complete any item listed below will require the BATC Contractor to perform this service free of charge when discovered, regardless of how much time has lapsed since the original demo project.
 - Prior to starting the decommissioning process, determine whether all points located within the controller are required to be decommissioned. If not, notify NYULH Facility Management Team to determine if the remaining points are to be relocated to a different controller or the controller is to remain.
 - The BATC Contractor shall be responsible for updating existing “as-built” drawings for any systems/equipment which is demolished.

Decommissioning of Software

- Remove all controller databases.
- Transfer all alarms, trends and graphics associated with the system to Decommissioned Links graphic.
 - Note: Decommissioned Links graphic shall not be made available to typical users. For use by the BATC Contractor and the NYULH Facility Management Team management only.
- Update all building and campus summary graphics to remove decommissioned systems.

Decommissioning of Hardware

- Determine whether the controller is the only controller on the power circuit. If so, label the circuit breaker (located in existing power distribution panel) as Spare.
- Determine if the controller is at end-of-run of communication loop or if communication loop is dedicated to this controller. If controller is not at end of run in communication loop, then re-terminate communication wiring such that existing controllers on same loop continue communications to server.
 - If controller is at end of run in communication loop, relocate any end-of-line resistors to the next controller in line.
- Disconnect the following from the controller:
 - Communication wiring.
 - Power wiring.
 - All field wiring.
- Remove conduit and wiring as much as possible. At a minimum, conduit and wiring shall be removed up to shaft or wall penetrations. Remaining conduit and wiring shall be tagged Not-In-Use.
- Remove all control panels and field devices. Coordinate with NYULH Facility Management Team to determine whether any of the existing controllers and field devices may be used as attic stock.

vii. Delivery, Storage and Handling

- Shipping and storage protection shall be provided by manufacturer to ensure that the interior and exterior of components are completely protected from damage, dirt or weather. Components shall be continuously covered with plastic or other durable means, until just prior to installation. Maintain protection after installation to protect against on-going construction activities.

viii. Project Closeout

General Requirements:

- The following items must be included within the “Project Closeout” section of the Contract Documents:
 - Systems will not be added to the BMS network until they are fully commissioned, training has taken place, and operation and maintenance manuals have been provided to the Facility Management Team.

- Training must be completed prior to occupancy and Facility Management Team acceptance.
- The BATC Contractor will provide onsite 24/7 coverage for all warranted systems until commissioning and training is complete and operations and maintenance manuals have been provided to the Facility Management Team.

Testing and Calibrating:

- Commission and test the final installed system prior to acceptance by the Facility Management Team.
- Furnish labor and test apparatus required to calibrate and prepare for service control components, instrumentation and field devices.
 - This work includes: Zero, span and range calibration checks of instruments and accessories, both field-mounted and panel-mounted. In addition, check actuators, control valves and dampers to ensure proper action. Stroke each valve and damper actuator and make necessary adjustments for stem and blade travel.
- Furnish labor and test apparatus required to check the operation of control loops, set points and interlocks. Test every input/output point for proper performance through the entire system and maintain accurate test records for each point throughout the testing cycle and thereafter. The Facility Management Team reserves the right to inspect those test records at any time and also to witness any of the point tests they deem appropriate.
- All equipment used for testing and calibration shall be NIST (National Institute of Standards and Technology) traceable and calibrated within the preceding 12-month period. Certificates of calibration shall be available for review by the Facility Management Team.

ix. Warranty

- Warranty direct digital control units, field devices, components, etc., to be free from defects in workmanship and material for a period of one (1) year from completion of final commissioning, which may occur beyond equipment acceptance and initial occupancy by NYULH. During this period, BATC Contractor shall furnish all labor to repair or replace all items or components that fail due to defects in workmanship or material.
- Failures on control systems, including all computer equipment, transmission equipment and all sensors and control devices during the warranty period, shall be adjusted, repaired or replaced at no additional cost or reduction in service to NYULH.
- Provide necessary preventive maintenance on the system during the warranty period. Provide updates to operator workstation and server software, project-specific software, graphic software, database software and firmware that resolve software deficiencies at no charge during warranty period.
- During the warranty period, BATC Contractor shall test the system under varying seasonal conditions to ensure that all operational sequences, as specified, are performed correctly.

- This shall include at least three additional visits after initial NYULH Facility Management Team acceptance. Where necessary, BATC Contractor shall make programming adjustments and instrument calibrations at no expense to NYULH.
 - At the end of the warranty period update “as-built” documentation to reflect any modifications made during the warranty period.
 - Uncompleted Work Period: At the end of the warranty period, a five year uncompleted work period shall begin. The uncompleted work period shall be used to determine if the BATC Contractor has completed the entire scope of work as required for the project. If work has been found to be incomplete or never installed, as determined by the NYULH Facility Management Team, the BATC Contractor shall be responsible for completing the work at no additional cost to NYULH.
- x. User Access Levels

Follow NYULH Critical Infrastructure Operational Technology (CIOT) Vendor Managed Device Standard.

- xi. Wire Jacket Color Requirements

Cables supporting BMS wiring shall adhere to the following colors for their outer jackets:

- CAT6 Ethernet: Blue
- Fiber: Orange
- 24VAC power: Teal with Yellow Stripe
- Twisted Pair (Third Party Integration)
 - BACnet MSTP: Orange
 - Modbus RTU: Yellow
- Analog and Binary I/O signals:
 - 2 Conductor: White with Blue Stripe
 - 3 Conductor: White with Yellow Stripe
 - 4 Conductor: White

C. Locations

- i. NYULH Main Campus

The following BMS manufacturers are acceptable for the furnishing and installation of DDC products as specified in this subsection for this location:

- a. Automated Logic Corporation
- b. Schneider Electric
- c. Laboratory Control Solutions: Kimmel Pavilion; Medical Science Building; Science Building; Smilow Research Center; Tisch Hospital, Skirball
 - i. Flow tracking applications
 - ii. Fume hood applications

ii. NYULH Long Island

The following BMS manufacturers are acceptable for the furnishing and installation of DDC products as specified in this subsection for this location:

- a. Tridium Niagara

iii. NYULH Brooklyn

The following BMS manufacturers are acceptable for the furnishing and installation of DDC products as specified in this subsection for this location:

- a. Trane Tracer

ii. NYULH LOH

The following BMS manufacturers are acceptable for the furnishing and installation of DDC products as specified in this subsection for this location:

- a. C&S Building Services

iii. NYULH Real Estate & Housing

For sites that have an NYULH managed BMS on premises, confirm in writing with the NYULH Real Estate group that the existing BMS network is sufficient and not obsolete.

For sites that do not have an NYULH managed BMS on premises the following BMS manufacturers are acceptable for the furnishing and installation of DDC products as specified in this subsection for this location:

- a. Schneider
b. ALC

D. People

The following individuals/groups are named throughout the BAS Standard:

- NYULH Project Manager
- NYULH Facility Management Team
- NYULH Senior Controls Specialists
 - For the NYULH Long Island campus, the Controls Shop Manager acts in this role
- NYULH Engineering and Commissioning
- NYULH MCIT
- Engineer of Record
- Building Automation Temperature Controls (BATC) Contractor

These individuals/groups are to produce, approve, be consulted on or be informed of all deliverables as indicated in the Deliverables Approval Matrix.

Deliverables Approval Matrix:

	Project Manager	Facility Management Team	NYULH Senior Controls Specialists	Engineering and Commissioning	MCIT	Design Engineer of Record	Construction BATC Contractor
Drawings & Specifications							
Control Single Line Diagrams	I	C	C	C	-	P	I
Smart Comfort Program Strategies	I	C	C	C	-	P	I
BAS Submittal							
Floor Plan with Proposed Panel and Wall-Mounted Device Locations	I	C	C	C	-	A	P
BMS System Graphics	I	C	C	C	-	A	P
Control Valve Schedule	I	C	C	C	-	A	P
Network Architecture Diagram	I	C	C	C	I	A	P
Schedule of BMS Alarms	I	C	C	C	I	A	P
Controller Reboot and Power Failure Restart Sequence	I	C	C	C	-	A	P
Test Forms	I	I	C	C	-	A	P
Remainder of BAS Submittal	I	C	C	C	-	A	P
Closeout Documents							
As-Built Drawings	I	I	I	C	-	A	P
72-Hour Trend Reports	I	I	C	C	-	A	P
Operation and Maintenance Documentation	I	I	I	C	-	A	P
As-Built Database	I	I	C	C	-	A	P
Acceptance Documents	I	A	I	C	-	-	P

Legend

- A Approver: Must provide approval of document prior to implementation
- C Consulted: Provided opportunity to review document ahead of approval.
If document deviates from BMS Standard document, consulted party must review the deviation.
- I Informed: Included on transmission of pre-approved and post-approval documents
- P Producer: Develops and submits the document for review and approval.

Approved BMS Vendors:

Reference the NYULH Approved Vendors List for vendors that are authorized to install the site-specific BMS manufacturer’s product line.

E. Deliverables

- i. Drawings & Specifications
 - a. Control Signal Line Diagrams

The Engineer of Record shall produce one control single line diagram per system type. Each shall consist of the following:

- Piping and instrumentation diagram
- Hardwire interlocks
- All required BAS points, alarms and trends

Reviews shall be conducted by:

- Facility Management Team
- Senior Controls Specialists
- Engineering and Commissioning
- NYULH Real Estate & Housing (for NYULH Real Estate & Housing locations only)

b. Smart Comfort Program Strategies

Energy Saving Strategies:

- Engineer of Record shall analyze each individual space and consider its use to develop a strategic energy saving sequence during unoccupied periods.
- These areas shall also have a means of placing the system back into an occupied mode
- Strategies that shall be considered, but not limited to, are as follows:
 - Flow Setbacks
 - Temperature setbacks
 - Lighting control

Reviews shall be conducted by:

- Facility Management Team
- Senior Controls Specialists
- Engineering and Commissioning
- NYULH Real Estate & Housing (for NYULH Real Estate & Housing locations only)

ii. BAS Submittal

- All BAS submittals shall be developed using approved submittals and shop drawings. Design documents as well as non-approved submittals and shop drawings are not acceptable for use in BAS submittal development.

Submittals for each project, regardless of scope and size, shall consist of the following:

- All subsections of the BAS Submittal that shall be submitted as independent deliverables.
 - Network Architecture Diagram
 - Control Valve Schedule
 - Floor Plan with Proposed Panel and Wall-Mounted Device Locations
 - Schedule of BMS Alarms
 - BMS System Graphics
 - Controller Reboot and Power Failure Restart Sequence
 - Test Forms

- Compliance document consisting of Specifications 23 0900 and 23 0993 and, at each section, paragraph and subparagraph, identify compliance or non-compliance by C (Comply), D (Deviate) or E (Exception). For each D and E item, describe what specific alternative approach has been taken.
- Specification sheets for each type of electronic sensors, transmitters, controllers, actuators, relays, switches and miscellaneous control devices.
- Schedule and specification sheets for control damper actuators, including material and construction details, duct size, damper size, actuator mounting location and quantity of actuators. Actuator sizing calculations and configuration shall be submitted. Actuators to be selected based on approved sheet metal shop drawings and damper submittals.
- DDC controller point list.
- Point nomenclature.
 - Projects which are adding or modifying equipment in an existing NYULH site with an existing BMS, keep reference and point names consistent with the rest of the system. This applies to graphics, program definition, etc.
- Control diagrams for each system with a written sequence of operation and control devices identified with instrument tag numbers. Control diagrams to include symbol and abbreviation list.
 - Sequence of operation shall not be a facsimile of the engineer's project documentation
 - Note: For variable air volume air handling systems, control diagrams are to indicate field installed location of end of duct static pressure transmitters.
- The BMS vendor must include detailed panel control layout in the submittal drawings, including all associated devices such as controllers, circuit breakers (CB), power supplies (PS), transformers (TX), control relays (CR), terminal blocks, wire ducts, and labels. Check figure CPL-01 as a reference for the control panel layout. Figure CPL-01A shows the control panel layout if the control panel has an external power source control panel. Ladder-type electrical diagrams for each control system with terminal connections identified by number and location. Include symbol and abbreviation list for electrical control diagrams.
- Complete listing and description of program routines resident in direct digital control units.
- Schedule of all points trended for each system. Schedule to include system name, system tag, control panel serving equipment, point name, point description and trend interval.
- Riser diagrams for power and communication with locations labeled for all controllers, transformers and other relevant control components.
- Panelboard from which power shall be taken, along with total power to be taken from each panelboard.
- Interfaces (software and hardware) with equipment provided in other subsections of the specifications. Show connection details based upon the approved submittals of the equipment being interfaced with. For software interfaces (i.e., BACnet, Modbus, etc.), submit list of all interface points transmitted to or received from the equipment.
- List of OEM equipment interface points as well as configuration point mapping.

- Mechanical piping shop drawings indicating proposed locations of all temperature, flow and pressure transmitters.
- Wiring and control diagrams, dimension and specification sheets, and sequence of operation for the flow-tracking system and all of its components.
- Note: For projects where minor modifications are made to an existing control system, submittal documentation shall be inclusive of all existing control work associated with the system as well as the new work provided as part of the project. Existing work shall be identified as shadowed block areas or other means acceptable to NYULH Facility Management Team. New work shall be bold. Intent is to have a comprehensive submittal indicating all existing and new control work associated with the system.
- Reviews shall be conducted by:
 - Senior Controls Specialists
 - Engineering and Commissioning
 - Approval shall be by Engineer of Record
- The following submittals can be included in the overall BAS submittal or submitted as standalone documents:

a. Network Architecture Diagram

Submittal shall consist of the following:

- System Architecture Drawing Indicating Tie-In Points, Hardware, Cabling Distances, Controllers, Equipment Served, Etc.
- Architectural floor plans indicating proposed location of communication loop and risers.

Reviews shall be conducted by:

- Senior Controls Specialists
- Engineering and Commissioning
- Approval shall be by Engineer of Record

b. Control Valve Schedule

Submittal shall consist of the following:

- Schedule of automatic control valves and motorized block valves. The schedule shall list body pressure rating, close-off pressure rating, flow coefficient (Cv), pressure drop at specified capacity, rangeability and valve flow characteristics.
- Specification sheets for each valve.
- Valves shall be sized based on approved equipment shop drawings, not mechanical schedules.

Reviews shall be conducted by:

- Senior Controls Specialists
- Engineering and Commissioning
- Approval shall be by Engineer of Record

c. Floor Plan with Proposed Panel and Wall-Mounted Device Locations

Submittal shall consist of the following:

- Architectural floor plans indicating proposed locations of all wall-mounted devices (i.e., DDC units, control panels, sensors, thermostats, risers, etc.).

d. Schedule of BMS Alarms

Submittal shall consist of the following:

- Schedule of all alarms (hardwired and software-generated) for each system. Schedule to include system name, system tag, control panel serving equipment, point name, point description and alarm value.
- Description of smart alarm program as it applies for each system.

Reviews shall be conducted by:

- Senior Controls Specialists
- Engineering and Commissioning
- Approval shall be by Engineer of Record

e. BMS Graphics

Submittal shall consist of the following:

- PDF copies of proposed graphics to be added to the BMS.
- BMS graphics to show proposed layout of BAS points and any diagrams or tables as required.
- BMS graphics shall be developed based on NYU standard graphic symbols, colors and design as found in the Smarts section under HMI/Graphics.
- All BMS graphics shall be coordinated with NYULH.
- BMS graphics shall include system maps showing overlays of single line mechanical systems.
 - System map overlays shall be allowed to toggle between Off, Supply, Exhaust, Supply and Exhaust, Reheat Water, Chilled Water and Perimeter Hot Water systems.

Reviews shall be conducted by:

- Facility Management Team
- Senior Controls Specialists
- Engineering and Commissioning
- Approval shall be by Engineer of Record

f. Controller Reboot and Power Failure Restart Sequence

Submittal shall consist of the following:

- Detailed description of software program for controller reboot sequence.
- Detailed description of software program for controller power failure restart program sequence.
- On controller reboot or return from power failure, all control loop outputs shall be commanded to their position prior to reboot or power failure and all control loop integrals shall be zeroed, thus eliminating reset windup.

Reviews shall be conducted by:

- Senior Controls Specialists
- Facility Management Team
- Engineering and Commissioning
- Approval shall be by the Engineer of Record

g. Test Forms

Submittal shall consist of the following:

- Checklists of testing procedures, including point-to-point wiring and sequence check.

Reviews shall be conducted by:

- Engineering and Commissioning
- Approval shall be by Engineer of Record

iii. Closeout Documents

a. Acceptance Documents

The following Closeout Documents shall be reviewed and accepted prior to final acceptance of the project by NYULH:

- Operation and Maintenance Documentation
 - As-Built Drawings provided in PDF, and editable Visio or AutoCAD format
 - As-Built Database
- 72-Hour Trend Reports
- BAS Vendor Service Agreement

b. Operation and Maintenance Documentation

On completion of installation, system commissioning and Facility Management Team acceptance, the BATC Contractor shall provide operation and maintenance manuals.

Manuals shall be updated each time changes are made to the system.

Manual shall be submitted through BuildFlow electronically. In addition, one hard copy shall be furnished in a three-ring binder and provided to the local Engineering Office.

Operation and maintenance documentation shall consist of the following:

- Table of contents
- As-Built Drawings provided in PDF, and editable Visio or AutoCAD format
- Programming manual containing the following:
 - Documentation of all project-specific application and BMS programs
 - All passwords and/or required access credentials
 - Complete final point schedule including all hardware and software data points and documentation of calibration and configuration values for all inputs, outputs, variables and PID loops at the conclusion of system commissioning and functional testing
 - System database as functional at the conclusion of system commissioning and functional testing, including all graphics and images used by and/or created on electronic format
- Parts list containing supplier information (manufacturer name, address, telephone number and website address) with complete component model number and ordering information.
- Final calibration, commissioning and testing reports.
- Warranty letters for all installed systems and components.

Operation and maintenance manual must be submitted to the Facility Management Team prior to occupancy. Systems will not be accepted by NYULH without submission and approval of operation and maintenance manuals.

i. As-Built Drawings provided in PDF, and editable Visio or AutoCAD format

Submittal shall consist of the following, which shall represent the "as-built" condition of the system and incorporate all information supplied with the approved submittals, inclusive of:

- Updated existing system architecture drawing, inclusive of any modifications made during the project construction.
- Indicating Tie-In Points, Hardware, Cabling Distances, Controllers, Equipment Served, Etc.
- Sequence of operation
- Bill of Material
- Control diagrams depicting controlled system configuration indicating all field devices
- Control panel wiring diagrams
 - Include power panel number and circuit breaker number feeding each control panel
- Starter/VFD interface wiring diagrams
- Point list for all hardwired input/output points
- Point list for all input/output points derived via communication interface (i.e., BACnet, Modbus, etc.) with third-party equipment such as air conditioning units, variable frequency drives and chillers
- Floor plans indicating exact location of all devices
- All other items listed as requirements of the BAS Submittal

Note: For projects where minor modifications are made to an existing control system, "as-built" documentation shall be inclusive of all existing control work associated with the system as well as the new work provided as part of the project. Existing work shall be identified as shadowed block areas or other means acceptable to the Facility Management Team. New work shall be bold. Intent is to have a comprehensive "as-built" shop drawing indicating all existing and new control work associated with the system.

Reviews shall be conducted by:

- Engineering and Commissioning
- Approval shall be by the Engineer of Record

With each local control panel, provide a paper copy of the "as-built" control diagram, sequence of operation, bill of material and point list for

the equipment served by the control panel. Documentation shall be placed in a plastic sleeve located on the inside of the door.

ii. As-Built Database

A composite “as-built” database shall be created and updated at completion of each project.

The database shall consist of the following:

- All “as-built” documentation
- Project start and completion dates
- Warranty start and completion date
- Brief description of project scope
- Names of the BATC Contractor project team:
 - Project Manager
 - Field technicians
 - Software programmers
 - Subcontractor name and contact information
- Software database
- Software shall be accessible via dynamic link on respective equipment graphics

c. 72-Hour Trend Reports

Submittal shall consist of the following:

- Trending data for 72-hour automatic system operation.
- Trending data to include all relevant hardwired and software data points associated with the system that shall indicate that the system is operating as per design intent.

Reviews shall be conducted by:

- Senior Controls Specialists
- Engineering and Commissioning
- Approval shall be by Engineer of Record

F. Performance and Functional Requirements

i. System Requirements

Note: for details on the software functions listed for each system, see the corresponding software function in the “Functional Requirements” section.

a. Constant and Variable Air Volume Terminal Units (Non-Flow Tracking Applications)

Hardware

- Pressure-independent unitary controller shall be furnished by BMS vendor utilizing differential pressure sensing.
- Damper actuator shall be fail-in-place type.
- For terminal units with reheat coils, provide discharge temperature transmitter.
- Reheat coil control valves shall be spring-return fail-closed.
- Space temperature sensor located in occupied areas shall be indicating and adjustable with a limit of $\pm 3^{\circ}\text{F}$ (adjustable).
 - Where multiple sensors are installed in a room served by multiple terminal units, only one sensor shall be indicating and adjustable type.
 - Set point adjustment shall be common for all terminal units serving a room.
- Space temperature sensors located in unoccupied or transient areas such as corridors are to be non-indicating and non-adjustable.
- Space temperature sensors for vivarium spaces shall be duct-mounted. Setpoints shall be adjusted via BMS only.
- Transformer, damper actuator, unitary controller with differential pressure transmitter and fuse shall be mounted in a NEMA 1 steel enclosure with removable screw cover. Disconnect switch to be mounted external to panel. Switch activation shall not require removal of enclosure panel.
- Provide occupancy sensors to enable setback functions

Software

- Occupied/Unoccupied Control
- Air Volume Control (Non-Tracking)
- Night Setback
- Shared Perimeter Radiation Valve Control
- Cooling and heating set points should adjust up and down and maintain a built-in bias of 2°F (adjustable).
- All boxes must contain a k-factor in the software depending on box size according to manufacturer as well as a calibration factor.
 - Formula: $\text{Sqrt}(\text{Velocity Pressure}) * (\text{Box Size k-factor}) * (\text{Balancer's Reading} / \text{BMS Reading})$
- Alarms
- Demand Response
- Air quality system interface for air change rate adjustment
- Controller Reboot or Return from Power Failure

Points

- Terminal unit airflow reading
- Terminal unit airflow set point
- Discharge temperature (for units with reheat coils only)
- Discharge temperature set point (for units with reheat coils only)
- Reheat coil valve command (for units with reheat coils only)
- Space temperature
- Space temperature set points
- Space temperature high and low alarm limits
- Occupied heat/cool set points
- Unoccupied heat/cool set points
- Damper position
- Occupancy mode
- Perimeter radiation valve command (for units with perimeter heating only)
- Include six additional software points to be defined by NYULH.

b. Fan Powered VAV

All system requirements listed under Constant and Variable Air Volume Terminal Units (Non-Flow Tracking Applications) apply to Fan Powered VAVs as well. In addition, provide the following:

- Run status monitoring of fan via current-sensing relay.
- On actuation of a life safety alarm in the area served by the terminal unit, the unit fan shall stop and the primary air damper shall fully open.
- Additional points:
 - Fan start/stop
 - Fan run status

c. Flow-Tracking Applications

All system requirements listed under Constant and Variable Air Volume Terminal Units (Non-Flow Tracking Applications) apply to Flow-Tracking Applications as well. In addition, provide the following:

- A control panel for each tracking pair that shall contain the control unit, supply terminal unit differential pressure transmitter and control transformer. The supply terminal unit shall contain a unit-mounted electric spring-return actuator, flow cross airflow sensor, and supply air temperature transmitter (located downstream of the reheat coil). The exhaust terminal unit shall contain a unit-mounted electric spring-return actuator, exhaust terminal unit differential pressure transmitter and flow cross airflow sensor.
 - Minimum airflow sensor measurement accuracy shall be $\pm 5\%$ of actual airflow and shall have a repeatability within $\pm 0.15\%$ over the entire airflow range of each air terminal.

- Additional software functions:
 - Flow Tracking Control
 - Fume Hood Control
- Additional points:
 - Fume hood exhaust flow
 - Fume hood exhaust low-flow alarm.
 - Supply/makeup airflow
 - General exhaust flow
 - Total exhaust flow
 - Total supply flow
 - Room offset
- Flow-Tracking Terminal Units Associated with Fume Hoods: Damper actuators for supply, general exhaust and fume hood terminal units shall have an electric spring return actuator (4-20 mA input signal) factory-mounted to each terminal unit. Loss of electric power or control signal shall cause the exhaust damper to fail open to the maximum scheduled design flow, and the supply damper to fail closed to the minimum scheduled design flow. Electric actuator stroke time shall not exceed 1.0 second for flow change from minimum flow to ninety percent (90%) at nominal load. Actuator shall be maintenance-free high-speed type with manual override and shall meet NEC Class 2 requirements.
- Flow-Tracking Terminal Units without Fume Hoods: Damper actuators for supply and general exhaust terminal units shall have an electric spring return actuator (0-10 VDC or 2-10 VDC input signal) factory-mounted to each terminal unit. Electric actuator stroke time shall not exceed 90 seconds. Actuator shall be maintenance-free high-speed type with manual override and shall meet UL Class 2 requirements. Actuator shall be either 120 VAC or 24 VAC.
- Spider-type multiple-probe airflow-sensing tubes of the automatic averaging type shall be 316 or 304 stainless steel. Accuracy of the sensing tubes shall be $\pm 2.0\%$ with a repeatability of 0.3% over a range of 0 - 3,000 ft./min. at 1 duct diameter upstream straight run duct. The flow signal shall also be used as the input to the BMS and also for balancing and field-measurement of air volume.

The following pertains specifically to fume hoods:

- Operational Parameters (to be available to the NYULH Facility Management Team and authorized service personnel):
 - Fume hood average face velocity set point
 - Fume hood minimum and maximum exhaust airflow set points
 - Face velocity high and low alarm limits and associated alarm time delay to avoid transient alarms
 - Face velocity high and low warning limits
 - Emergency purge time periods and exhaust levels
 - Allowable maximum sash opening associated with the sash alert feature

- Pushbutton: Provide a mushroom-type pushbutton and local audible annunciation (i.e., horn) located at the exit door of each area that contains a fume hood. The switch shall, on annunciation, drive the fume hood to maximum airflow. On activation of the pushbutton switch, the audible alarm shall be activated. Switch and audible alarm shall be provided with a label for user operation as per NYULH Health and Safety requirements. Labels shall state instructional operation and required actions that need to be performed, if needed. Switch shall be manually reset type furnished with protective cover to allow the switch to be viewable without tampering or accidental activation.
- Hood Interface Module: The hood interface module shall provide emergency override, high-flow alarm, low-flow alarm, hood status lights and programmable audible alarm. Audible alarm shall be no more than 85 dB at 1 meter (95 dB at 1 meter for constant volume applications). Module shall be designed to fit in a 2 inch by 4 inch (single-gang) electric box and mounted on the face of the fume hood. Connection using phone jack termination. All alarm set points shall be fully field-programmable as well as the time delay interval prior to alarming. Module shall also allow high/low sash alarms and limits (does not apply to constant volume applications). All points shall be monitored at the flow-tracking control unit. Alarm and mute functions shall automatically reset when the alarm condition ceases to exist. Alarm annunciation shall be as follows:
 - Normal Condition: Green LED lighted
 - Alarm Condition: Red LED lighted, indicating either:
 - Low face velocity (low hood airflow for constant volume applications)
 - High face velocity (high hood airflow for constant volume applications)
 - Emergency override
 - Caution or Control Transition: Green and red LED's flash alternately
 - Buzzer: Energized in any alarm or override condition
 - Pushbutton Functions
 - Override: Push once
 - Reset to Normal Operation: Push once
 - Alarm Acknowledgment (Audible Mute): Push twice (LED remains lighted while alarm condition exists)

d. Air Handling Units

Hardware

- BACnet IP-based direct digital control unit per air handling unit
- Provide BACnet or Modbus communication interface with variable frequency drive
- Chilled water return temperature transmitter
- Mixed-air temperature transmitter
- Utilize latching relays for air handling units serving critical areas (i.e., OR's, Laboratories, Vivarium, patient areas)

- Humidifier valve control signal to be wired in series with fan run status contact. If fan is off, humidifier valve hardwired to close.
- Damper actuators (outdoor, return, spill) must have spring-return actuators with manual override.
- Each preheat coil section to have individual temperature control valve with dedicated temperature sensor for low-limit control.
- Cooling coil to have one control valve for entire coil section with individual manual balancing valves on individual coil sections.
- VFD's must be programmed to skip resonance frequencies.

Software

- Occupied/Unoccupied Control
- Supply Air Temperature Control
- Preheat Coil Low-Limit Control
- Humidification Control
- Dehumidification Control
- Supply Fan Static Pressure Control
- Flow Control
- Airside Economizer Control
- Minimum Outdoor Airflow Quantity Control
- Indoor Air Quality Control
- Floor/Area Isolation Dampers (Combination Fire/Smoke Dampers)
- Fan Shutdown Mode
- Fire Alarm Reset
- Lead/lag Control
- Controller Reboot or Return from Power Failure

e. Packaged Air Conditioning Units

Hardware

- Unitary controller shall be furnished by BMS vendor
- Utilize latching relays for air conditioning units serving critical areas
- Leak detector
- Current-sensing relay for fan run status
- Space temperature sensor

Software

- The unit shall be started locally and run continuously. The BMS shall be capable of starting and stopping the unit.
- When running, the unit shall modulate the chilled water valve to maintain space temperature.
- A point-type leak detector in the unit's drip pan shall be installed and wired to the BMS for alarm monitoring only. On activation of a leak detector, the respective unit shall continue to run and an alarm shall be activated at the operator workstations.

Points

- Fan start/stop
- Fan run status
- Space temperature
- Space temperature set point
- Chilled water valve position
- Fan failure alarm
- Common alarm
- Leak alarm
- High space temperature alarm
- Low space temperature alarm

f. Fan Coil Units

Hardware

- Unitary Controller shall be furnished by BMS vendor
 - Note: Unitary controller is to be powered by a transformer that is energized on its primary side from the line side of the power feed to fan coil unit. This is to prevent a communication loss to the controller when the fan coil unit is shut down for maintenance.
- Utilize latching relays for fan coil units serving critical areas.
- Leak detector
- Current-sensing relay for fan run status
- Space temperature sensor
- Spring-return normally closed modulating control valve for cooling
- Spring-return normally closed modulating control valve for heating
 - If fan coil unit has ducted unconditioned outdoor air, provide normally open valve for heating.

Software

- Fan Coil Unit Control

Points

- Fan start/stop
- Fan run status
- Space temperature
- Space temperature set point
- Fan failure alarm
- Leak alarm
- High space temperature alarm

g. Exhaust Fans

Hardware

- Unitary controller shall be furnished by BMS vendor
- Low suction and discharge pressure switches
- Space temperature (as required)
- Provide BACnet or Modbus communication interface with variable frequency drive (as applicable)

Software

- Exhaust Fan Control

Points

- Fan start/stop
- Fan run status
- Fan failure alarm
- High space temperature alarm
- Pressure switch alarms

h. Chillers

Hardware

- BACnet IP-based direct digital control unit to serve fifty percent (50%) of chilled water plant equipment (e.g., chillers, pumps, cooling towers). Provide two control units per chiller plant.
- Provide BACnet communication interface with factory-provided chiller control panel.
- Utilize latching relays for enable/disable.
- Provide field devices for chilled water supply temperature and condenser water return temperature.

Software

- Chiller Control
- Lead/lag Control

Points

- Enable/disable (hard-wired)
- Common alarm (hard-wired)
- Chiller run status
- Chilled water supply temperature
- Condenser water return temperature

i. Cooling Towers

Hardware

- Control to be incorporated within chiller BACnet IP controller or dedicated controller based on location of cooling tower with respect to chillers.
- Monitor vibration alarm.
- Monitor basin water temperature.
- Monitor basin level.
- Utilize latching relays for start/stop.

Software

- Cooling Tower Control
- Lead/Lag Control

Points

- Cooling tower start/stop (hard-wired)
- Cooling tower run status (hard-wired)
- Condenser water supply temperature (hard-wired)
- Condenser water return temperature (hard-wired)
- Cooling tower fan runtime
- Basin water temperature
- Basin level
- Speed feedback
- Output frequency
- Current (amps)
- % torque
- Power (kW)
- Kilowatt hours
- Operating hours
- Drive temperature
- All diagnostic warning and fault information
- Remote fault reset
- Keypad “Hand” or “Auto” selected
- Bypass selected
- Motor running in bypass mode
- Motor running in inverter mode
- Cooling tower vibration alarm
- Basin low water temperature alarm
- Basin high water level alarm
- Basin low water level alarm
- Cooling tower fan excessive runtime alarm

j. Pumps

Hardware

- Provide BACnet or Modbus communication interface with variable frequency drive.
- Utilize latching relays for start/stop.
- Differential pressure transmitters used for pump speed control shall be hardwired directly to the controller containing the analog output for pump speed control regardless of the transmitter location.

Software

- Variable Speed Pump Control
- Lead/Lag Control

Points

- Pump start/stop (hard-wired)
- Pump run status (hard-wired)
- Speed command (hard-wired)
- Speed feedback
- Output frequency
- Total Runtime
- Current (amps)
- % torque
- Power (kW)
- Kilowatt hours
- Operating hours
- Drive temperature
- All diagnostic warning and fault information
- Remote fault reset
- Keypad “Hand” or “Auto” selected
- Bypass selected
- Motor running in bypass mode
- Motor running in inverter mode

k. Heat Exchangers

Hardware

- BACnet IP-based direct digital control unit to serve water system, including pumps and heat exchangers.
- For systems with multiple heat exchangers, provide a supply water temperature sensor per each heat exchanger.

Software

- Lead/lag Control

Points

- Supply water temperature (common plus individual, if applicable)
- Return water temperature (common plus individual, if applicable)
- High supply water temperature alarm
- Low supply water temperature alarm

I. Expansion Tanks

Hardware

- Pressure transmitter

Points

- High pressure alarm (set point shall be 5 psi above operating pressure)
- Low pressure alarm (set point shall be 5 psi below operating pressure)

ii. Functional Requirements

a. Fan Shutdown Mode

- On a command to stop a fan, the fan shall ramp down to its minimum speed and the fan shall stop.
- The fan discharge damper shall close slowly and shall not be fully closed until fan speed has decreased to approximately ten percent (10%).
- The outdoor, return and spill air dampers shall close after the fan has stopped and the discharge damper has closed fully.
- Refer to Unoccupied Mode.

Requirement applies to the following systems:

- Air handling units

b. Floor/Area Isolation Dampers (Combination Fire/Smoke Dampers)

- Supply floor/area isolation dampers shall open when the supply fan serving the damper is started and shall close when the fan serving the damper are stopped.
- Return floor/area isolation dampers shall open when the return fan serving the damper is started and shall close when the fan serving the damper is off.
- All supply and return dampers on a floor shall be controlled in a group via a hardwired connection to their respective fan's variable frequency drive.
 - Supply dampers shall be grouped independently of return dampers.
- Dampers shall be positioned open prior to fan starting regardless if fan is started from BMS, manual command from VFD, bypass function of VFD or fan start from fire alarm system.
- End switch status of dampers shall be monitored.

Requirement applies to the following systems:

- Air handling units
- c. Preheat Coil Low-Limit Control
- The normally open steam preheat coil control valves, one (1) per coil, shall be under control of DDC software low-limit controllers to maintain a minimum air temperature of 45°F leaving the preheat coils, signal as sensed by temperature transmitters on the leaving air side of each coil section.
 - The low-limit set point shall be reset by the BMS based on outside air temperature. As outside air temperature drops, the low-limit set point shall be raised. Reset parameters shall be adjustable.
- d. Airside Economizer Control
- Economizer control will be enabled based on the following conditions:
 - Global outside air enthalpy is enabled (i.e., outdoor air enthalpy is greater than 25 BTUs per pound of dry air) or outside air temperature plus an outside air temperature trigger deadband (adjustable) is less than the air handling unit return air temperature.
 - Supply fan status is proven on.
 - System is not operating in Warm-Up/Cool-Down Mode and Heating is off.
 - When enabled, the outside air damper, spill air damper and return air damper will modulate to maintain a mixed air temperature control set point (adjustable).
 - The mixed air control set point will be adjusted based on the supply air temperature error set point.
 - The supply air temperature error set point is based on how far off the supply air temperature is from the supply air temperature set point.
 - For example, if the supply air temperature is 53°F and the supply air temperature set point is 55°F then the supply air temperature error set point is -2°F.
 - A mixed air temperature error set point of 0 °F (adjustable) will control to the supply air temperature error set point and output a mixed air temperature heat gain set point.
 - The mixed air temperature heat gain set point will range from a minimum mixed air temperature heat gain set point of -4°F (adjustable) to a maximum mixed air temperature heat gain set point of 5°F (adjustable).
 - The supply air temperature set point minus the mixed air temperature heat gain set point will determine the mixed air temperature control set point.
 - As the mixed air temperature increases above mixed air temperature control set point, the outside air damper and spill air damper will modulate open and the return air damper will close proportionately.

- The reverse will occur on a decrease below the mixed air temperature control set point.
- The outside air damper will maintain a minimum outside air flow set point (adjustable based upon the Minimum Outdoor Air Flow Quantity Control functional requirement).

Requirement applies to the following systems:

- Air handling units

e. Night Setback

- Whenever the terminal unit fan is off, the system shall operate in the unoccupied mode.
- During this mode, a DDC software program shall monitor the space temperature associated with a terminal unit.
- On sensing a drop in space temperature to 55°F (adjustable), the controller shall start the terminal unit fan and maintain space temperature set point by modulating the reheat coil control valve and perimeter radiation control valve.
- On achieving space temperature set point, the terminal unit fan shall stop, if still operating in the unoccupied mode, or continue to run switched to occupied mode.

Requirement applies to the following systems:

- Fan-powered variable volume terminal units with reheat and perimeter radiation

f. Supply Fan Static Pressure Control

- A static pressure transmitter shall be located in the supply air duct, upstream of the furthest terminal unit served by the air handling unit.
- The system's supply fan speed shall modulate to maintain supply static pressure set point.
 - As duct static pressure decreases, the controller output shall increase, to increase fan speed. On an increase in duct static pressure, the output of the controller shall decrease, to decrease fan speed.
 - A software auto/manual switch function shall enable the operator to override the output of the static pressure controller and adjust fan speed from the operator workstation or DDC controller.
- A second static pressure transmitter in the supply fan discharge duct shall act as a high limit safety.
 - If fan discharge static pressure exceeds its set point, the high-limit controller shall, through a software low selector, override the output of the system static pressure controller to proportionally reduce the speed

- of its respective supply fan to maintain fan discharge pressure high-limit set point.
 - The controller set point shall be reset such that no terminal unit shall operate at its fully open position to maintain airflow set point.
- Static pressure controls shall control system operation during all cycles of operation.
- A DDC static pressure software program shall monitor the position of variable air volume terminal unit dampers and shall calculate the quantity of dampers that are less than eighty percent (80%) open.
 - If the majority of terminal units are less than eighty percent (80%) open, the DDC software controller shall reset the supply fan static pressure set point downward in 0.1 inch w.c. (adjustable) increments every 5 minutes until the majority of the dampers are at 80% open. If the majority of the dampers are more than ninety percent (90%) open, the program shall reset the set point upwards in 0.1 inch w.c. (adjustable) increments every 5 minutes until the majority of the dampers are at eighty percent (80%) open.
- During system start-up, the static pressure control algorithm, integral control mode, shall be suppressed until the control point is within the proportional band of the controller to avoid reset windup.

Requirement applies to the following systems:

- Air handling units
- g. Minimum Outdoor Airflow Quantity Control
- An airflow-measuring station installed upstream of the minimum outside air damper shall measure minimum airflow and transmit this information to the BMS.
 - Should outside airflow be below set point, the return air damper shall be modulated closed and the spill damper open until the minimum outside airflow is at set point.
 - Should outside air flow be above set point, the return air damper shall be modulated open and the spill damper closed until the minimum outside air flow is at set point.
 - If the outside air flow continues to be above set point, the minimum outdoor air damper shall modulate to a preset minimum value.
 - This program shall be overridden whenever the variable outdoor air damper is open during the economizer mode of operation.
 - Minimum outdoor air damper shall be modulating type.

Mixed air low limit temperature control:

- If the mixed air temperature sensor decreases below a mixed air low limit set point of 39°F (adjustable), the outside air damper and spill air damper will modulate closed and the return air damper will modulate open.
- This function shall override Minimum Outdoor Airflow Quantity Control.

Requirement applies to the following systems:

- Air handling units

h. Fire Alarm Reset

- After a fire alarm shutdown, the system shall automatically restart as long as no safety interlocks require a manual reset.
- Unit shall resume operation to maintain last known setpoints prior to fire alarm shutdown.

Requirement applies to the following systems:

- Air handling units

i. Flow Control

- The unit's DDC controller shall contain a software-based flow control program. The software controller shall receive input signals from airflow-measuring stations installed in the inlet of its respective supply and return fan, and totalize, linearize and scale them.
- The flow control program shall match the return fan with the supply fan and maintain the volumetric balance between return and supply airflow by varying return fan speed to maintain a constant differential between supply and return airflow.
 - For flow tracking systems, return fan differential is maintained by a dedicated static pressure transmitter located in the return ductwork. Return static pressure setpoint is calculated based on the desired differential.
- A software bias shall be provided to compensate the return flow for an outside air minimum reset, constant toilet exhaust and constant general exhaust at all operating loads.
- The operator shall be able to manually override the flow control program and manually control each supply and return fan.

Requirement applies to the following systems:

- Air handling units

j. Flow Tracking Control

- In all flow tracking applications, pressurization control shall take priority over temperature control.
- The master terminal unit shall modulate between its maximum and minimum flow setpoints to maintain space temperature.
 - For constant air volume systems, the maximum flow setpoint shall equal the minimum flow setpoint. The master terminal unit shall modulate to maintain a constant flow setpoint.
- The supporting terminal unit shall track the exhaust terminal unit to maintain a fixed air volume differential between the room supply and exhaust airflows.
- The supply temperature setpoint shall be reset to maintain space temperature upon a call for heating when the master terminal unit is maintaining minimum flow.
- The normally closed reheat coil valve shall modulate open to maintain supply temperature.
- For terminal units serving perimeter areas, the normally open perimeter radiation valve shall modulate to maintain supply temperature as the first stage of heating. The reheat coil valve shall modulate as the second stage of heating.
- The flow control system shall respond and maintain specific airflow ($\pm 5\%$ of signal) and stability ($< 5\%$ over/undershoot) within 1 second of a change in duct static pressure, irrespective of the magnitude of pressure and/or flow change or quantity of airflow controllers.
- The flow control system shall use volumetric offset control to maintain room pressurization. The system shall respond and maintain room pressurization (negative or positive) within 1 second of a change in room/system condition.
- The flow control system shall employ highly accurate microprocessor controllers with a minimum 8 to 1 (8:1) turndown to ensure accurate pressurization at low airflows and guarantee the maximum system diversity and energy efficiency. The end-to-end accuracy of the installed system shall be five percent (5%) over the entire range of the measurement.

The master and supporting terminal units are governed by the pressurization requirements as follows:

- Negative pressurization: the exhaust terminal unit acts as the master with the supply terminal unit supporting via air volume differential.
 - Upon loss of electric power or control signal, the supply damper shall fail closed and the exhaust damper shall fail open.
- Positive pressurization: the supply terminal unit acts as the master with the exhaust terminal unit supporting via air volume differential.
 - Upon loss of electric power or control signal, the supply damper shall fail open and the exhaust damper shall fail closed.

- Neutral pressurization: the exhaust terminal unit acts as the master with the supply terminal unit supporting with an air volume differential of zero (no differential).
 - Upon loss of electric power or control signal, the supply damper shall fail open and the exhaust damper shall fail closed.

The following requirements apply to rooms with multiple tracking pairs:

- All tracking pairs shall be controlled via a calculated average of all space temperature sensors.
- All terminal units must be maintaining their respective minimum flow setpoints prior to operation of any reheat or perimeter heating control valves.

The following requirements apply to rooms with fume hoods:

- In a room served by a fume hood, there shall be a wall-mounted emergency override pushbutton and local alarm light and horn. On activation of the pushbutton, the fume hood exhaust valve shall be positioned to maximum airflow and the general exhaust terminal units shall track accordingly. The alarm horn and light shall be activated. When the pushbutton is reset, the alarm light and horn shall be de-energized and the fume hood shall resume normal operation.
- The fume hood exhaust valve airflow shall be added to the general exhaust airflow. The supply terminal unit shall track the sum of the general exhaust and fume hood exhaust to maintain a fixed air volume differential.
- On an increase in fume hood exhaust airflow, the exhaust terminal unit airflow shall be reduced to maintain the room's exhaust flow setpoint.

k. Air Volume Control (Non-Tracking)

- Whenever the primary fan for the terminal unit is off, the terminal unit damper shall be fully open.
- The terminal unit shall modulate between its maximum and minimum flow setpoints to maintain space temperature.
 - For constant air volume systems, the maximum flow setpoint shall equal the minimum flow setpoint. The terminal unit shall modulate to maintain a constant flow setpoint.

The following requirements apply to terminal units equipped with reheat coils:

- The supply temperature setpoint shall be reset to maintain space temperature upon a call for heating when the terminal unit is maintaining minimum flow.
- The normally closed reheat coil valve shall modulate open to maintain supply temperature.

- For terminal units serving perimeter areas, the normally open perimeter radiation valve shall modulate to maintain supply temperature as the first stage of heating. The reheat coil valve shall modulate as the second stage of heating.

The following requirements apply to multiple terminal units serving a common room:

- The average of all space temperature sensors located in the room shall be used to calculate the terminal unit flow setpoint for each terminal unit serving the room.
- All terminal units shall be at minimum flow setpoint prior to operating any reheat coil or perimeter radiation control valve.

The following requirements apply to fan powered terminal units:

- A software interlock shall start the terminal unit fan when the primary fan serving the terminal unit starts.
- Start command to the terminal unit fan shall be delayed to allow the terminal unit damper to fully close. When the fan starts, the damper shall be allowed to modulate open.

I. Supply Air Temperature Control

- Supply air temperature control will be enabled when all of the following conditions are true:
 - Supply fan status is proven on
 - System is not operating in Warm-Up/Cool-Down Mode
 - When enabled, the cooling valve will modulate to maintain a supply air temperature control set point as sensed by a duct mounted supply air temperature sensor.
 - The supply air temperature control set point (adjustable) will be reset based on the worst case deviation of any of the following for all spaces being served by the system:
 - Temperature control: Space temperature vs. the space temperature set point (adjustable)
 - Dehumidification control: Space humidity vs. the humidification set point (adjustable)
 - Return air reset: in some applications, the supply air temperature set point shall be reset based on return air temperature
 - The supply air temperature control set point will range from a minimum supply air temperature set point of 45°F (adjustable) to a maximum supply air temperature set point of 65°F (adjustable).
 - As the supply air temperature increases above supply air temperature control set point the cooling coil valve will modulate open. The reverse

- will occur on a decrease below the supply air temperature control set point.
- The heating coil control valve will modulate to maintain a preheat supply air temperature control set point (adjustable).
 - The preheat supply air temperature control set point will be adjusted based on the supply air temperature error set point as described in the Economizer Control functional requirement.
 - A preheat supply air temperature error set point of 2°F (adjustable) will control to the supply air temperature error set point and output a preheat supply air temperature heat gain set point.
 - The reheat supply air temperature heat gain set point will range from a minimum preheat supply air temperature heat gain set point of -4°F (adjustable) to a maximum preheat supply air temperature heat gain set point of 5°F (adjustable).
 - The supply air temperature set point minus the preheat supply air temperature heat gain set point will determine the preheat supply air temperature control set point.
 - As the preheat air temperature decreases below preheat supply air temperature control set point, the steam heating coil valve will modulate open. The reverse will occur on an increase above the preheat supply air temperature control set point.
 - Preheat air temperature low limit control shall be operational in this mode as described in the Preheat Coil Low-Limit Control functional requirement.

Requirement applies to the following systems:

- Air handling units

m. Humidification Control

- Humidification control will be enabled based on the following conditions:
 - Supply fan status is proven on (Refer to Humidifier Valve Lockout below).
- A supply air dew point control loop will modulate the normally closed humidifier valve to maintain a supply air dew point set point as sensed by a duct mounted supply air humidity sensor and the supply air temperature sensor.
 - The supply air dew point set point (adjustable) will be reset based on the worst case deviation from space humidity to the humidification set point for all spaces being served by the air handling system.
 - The supply air dew point set point will range from a minimum supply air dew point set point of 30°F (adjustable) to a maximum supply air dew point set point of 50°F (adjustable).
 - The operator at the workstation shall have the ability to override the supply air dew point set point (adjustable) within the minimum supply air dew point set point and maximum supply air dew point set point.

- Humidification control will be overridden and the humidifier valve will modulate closed if the supply air humidity increases above a high limit humidity set point of 90% RH (adjustable) as sensed by the supply air humidity sensor.

Requirement applies to the following systems:

- Air handling units

n. Occupied/Unoccupied Control

The system shall operate based on a 7-day programmable schedule resident within the DDC controller serving the unit and adjustable at the operator workstation. The operator shall have the ability to override a starting or stopping of the system from the operator workstation or the DDC control unit.

Requirement applies to the following systems:

- Air handling units:
 - Operator shall also have the ability to override a starting or stopping of the associated return/spill fan
 - During unoccupied mode, the air handling unit shall not be in operation. The normally closed minimum outdoor air, variable outdoor air, return air, spill air and fan discharge dampers shall be closed. The return/spill fan shall be off. No control signal shall be transmitted to the variable frequency drive of each fan. The normally closed chilled water coil valve shall be closed. Steam humidifier valve shall be closed.
 - When the air handling unit is off, all combination fire/smoke dampers located in supply and return ducts shall be closed.
 - At the transition to occupied mode, the unit shall start. Prior to starting the air handling unit, all combination fire/smoke dampers located in supply and return air ducts shall open.
 - When the air handling unit start-up is initiated, its temperature control system shall be in operation. When the air handling unit is called to start, its supply fan discharge and return air dampers shall open. A hardwired time delay shall prevent fan operation, allowing sufficient time for the dampers to open. When the supply fan and return fan are started, they shall both run at the minimum speed required to maintain rotation. Minimum speed set point shall be coordinated with the variable frequency drive manufacturer. The start of each fan shall be time-delayed to avoid simultaneous starting of fans. After the fan has achieved minimum speed, the DDC controller shall ramp up the speed of the supply fan to maintain its operating set point.
 - When multiple fans are operating in parallel, all associated dampers must open before any single fan starts. Fans must be actively stopped from free rotation (via DC braking or some other means)

prior to start command. Fans must be started together and modulated at the same speeds throughout operation.

- Electronic face velocity controller for variable air volume fume hoods:
 - The system shall operate the fume hoods at a lower velocity set point (when it is safe).
- Flow tracking control unit:
 - The system shall setback air change rate setpoints in unoccupied mode.
- Variable air volume terminal units:
 - The system shall toggle between the occupied and unoccupied cooling and heating setpoints.
- Fan-powered variable volume terminal units with reheat and perimeter radiation:
 - The system shall toggle between the occupied and unoccupied cooling and heating setpoints.
- Constant air volume flow tracking systems:
 - The system shall toggle between the occupied and unoccupied cooling and heating setpoints.

o. Lead/Lag Control

- Lead and standby equipment shall be selectable via BMS command.
- Lead equipment shall be allowed an Automatic option which will rotate lead unit based on equipment runtime.
 - At rotation trigger (set via BMS schedule), the piece of equipment with the lowest runtime shall be set to lead.
- Equipment shall be monitored for run status. Loss of run status for lead equipment for 30 seconds shall constitute equipment failure.
 - A failure alarm shall be generated at the BMS.
 - The standby equipment shall start automatically.

Requirement applies to the following systems:

- Headered Exhaust Fans
- Pump Sets
- Cooling Tower Sets
- Heat Exchanger Sets
 - Parallel mode shall also be available, which shall operate all heat exchangers in tandem.
- Headered Air Handling Units

p. Fume Hood Control

- A UL 916-listed individual fume hood monitor shall be provided for each fume hood, which shall measure the average face velocity at the set point

independently of the sash position. Also, provide sash sensors on each fume hood to indicate the position of all fume hood sashes to the respective fume hood controller. Sash sensors shall provide an input signal to the fume hood controller that is linearly proportional to within one-half inch of the actual sash position. All sash sensors shall be highly corrosion-resistant and allow easy removal of a fume hood's sashes for cleaning. Sash sensor operational life shall allow a minimum of one million full sash travel cycles. Multiple sash sensors shall be utilized for combination vertical/horizontal sashes.

- The fume hood face velocity controller shall maintain the average fume hood face velocity at the desired setpoint using a proportional, integral and derivative (PID) closed-loop control algorithm.

The fume hood face velocity control process shall be as follows:

- The fume hood controller shall continually determine the fume hood's total open area by monitoring the fume hood sash position(s) by the sash sensor(s) as well as by taking account of any fume hood fixed open areas and the bypass opening(s).
- The fume hood controller shall calculate the required fume hood exhaust airflow necessary to maintain the average face velocity setpoint over the total open area.
- The fume hood controller shall control the fume hood exhaust airflow at the rate necessary to maintain the average face velocity setpoint.
- The fume hood controller shall ensure that the fume hood exhaust required to maintain the average face velocity set point is always maintained independently of any variations in exhaust system static pressure or any laboratory room conditions such as the ventilation airflow or room static pressure that could otherwise affect the fume hood exhaust airflow.

The following requirements apply to the fume hood monitor:

- The fume hood controller shall also interface to the hood interface module at the designated measurement location on the front of the fume hood. The hood interface module shall provide a continuous digital display of average fume hood face velocity, which shall be the true average face velocity as calculated by the fume hood controller based upon actual measured fume hood exhaust airflow and the total fume hood open area.
- The hood interface module shall also sound an audible alarm device in response to face velocity alarm conditions and the hood interface module digital display shall change to "LOW FACE VELOCITY" or "HIGH FACE VELOCITY" appropriate to the alarm condition. A "SILENCE" pushbutton on the hood interface module shall allow the user to silence the audible

alarm, which shall then remain silent until a subsequent face velocity alarm occurs.

- The hood interface module shall also provide an “EMERGENCY PURGE” pushbutton that shall enable a user to increase fume hood exhaust airflow to the maximum amount for a designated period of time as required by Laboratory safety standards. After the designated time has expired, the fume hood exhaust shall automatically reset to a lower level to prevent excessive demand on the exhaust system. The emergency purge mode of operation shall also be able to be canceled at any time by depressing the emergency purge button a second time. The hood interface module shall sound its audible alarm device whenever the emergency purge mode of operation is activated. The silence pushbutton on the hood interface module shall also allow the user to silence the audible alarm, which shall then remain silent until either the emergency purge operational mode is again activated or a face velocity alarm occurs.
- The hood interface module shall also provide an audible sash-open alert feature that shall caution users whenever the fume hood sash opening exceeds a predetermined amount. The audible alert shall consist of one minute repeating cycle of a series of quick “chirps” that continues until the sash opening is reduced to an allowable amount. In addition, failure of a fume hood sash sensor shall also be indicated as an alarm condition on the hood interface module.
- Momentary or extended losses of power shall not change or affect any VAV fume hood control set points, operational parameters or stored data. Upon resumption of power after a power failure, fume hood monitor shall resume full normal operation exactly as before the power failure and without any need for manual intervention. Upon a power failure or operational failure within the fume hood controller, the fume hood exhaust air terminal shall be automatically positioned to the fully open (fail-safe) position as required by Laboratory safety standards.

q. Shared Perimeter Radiation Valve Control

- The space temperature of each room shall be maintained by the supply air terminal unit and reheat coil serving the room.
- The shared perimeter radiation valve shall be used to satisfy the room which requires the greatest amount of heating.
- If any room requires heating, that room's terminal unit controller shall modulate its reheat coil control valve to maintain space temperature set point. The perimeter radiation control valve shall be allowed to operate in parallel with the reheat coil control valve until any room's space temperature is within 1°F below its cooling set point, at which time, the perimeter radiation valve shall modulate closed regardless of the heating demand of the other rooms. If any room's space temperature drops 1°F

below its cooling set point, the perimeter radiation valve shall modulate open in parallel with the reheat valve associated with that room.

r. Variable Speed Pump Control

- Pump speed shall modulate to maintain differential pressure setpoint.
- The differential pressure transmitter, used for speed control, shall be located upstream of the furthest connected equipment served by the pump.
- On a decrease in differential pressure below setpoint, the pump speed shall modulate higher until reaching full speed.
- On an increase in differential pressure above setpoint, the pump speed shall modulate lower until reaching minimum speed.
 - The pump minimum speed shall be limited to 30% (adjustable) of its design flow rate.
- On a further increase in pressure, the differential pressure valve shall modulate open to maintain system differential pressure.

s. Exhaust Fan Control

- When a fan is off, its intake and discharge dampers shall be closed.
 - All combination fire/smoke dampers located in associated ductwork shall be closed via hardware interlock with the fan.
- When the fan starts, a time delay relay shall prevent the fan from starting until its intake, discharge and combination fire/smoke dampers are fully open.
 - Proof of open damper position shall be provided via end switch with hardware interlock to fan.
- For fans that operate continuously, each fan shall be started by a manual command at the operator workstation.
- For fans that function to maintain space temperature, fan shall be started via space temperature.
 - On sensing a space temperature above set point, the exhaust fan shall start.
 - On sensing a decrease in space temperature to 5°F below set point, the exhaust fan shall stop.

t. Fan Coil Unit Control

- Fan coil unit shall be started and stopped through the BMS.
 - Fan run status shall be monitored at the BMS via a current-sensing relay.
 - On failure of the unit to operate, a fan failure alarm shall be activated at the workstation.
- When the fan is off, its chilled and hot water control valves shall be closed.

- The fan coil unit shall modulate the normally closed chilled and hot water valves in sequence to maintain space temperature setpoint.
 - On an increase in space temperature above setpoint, the unit shall modulate the hot water valve closed and chilled water valve open.
 - As the temperature decreases, the reverse shall occur.
- A point-type leak detector in the unit's drip pan shall be installed and wired to the BMS for alarm monitoring only.
 - On activation of a leak detector, the respective unit shall continue to run and an alarm shall be activated at the operator workstation.
- On sensing a space temperature 5°F above set point, an alarm shall be activated at the workstation. On a decrease in space temperature to within $\pm 2^\circ\text{F}$ of set point, the alarm shall be reset.

u. Chiller Control

- Prior to enabling chiller operation, respective chilled and condenser water pumps shall start and chiller's condenser and evaporator isolation valves shall be open.
 - Proof of pump status shall be via current sensing relay.
 - Proof of isolation valve status shall be via end switch.
- When chiller is in operation, its factory-furnished OEM controller shall stage compressors to maintain leaving water temperature set point.

v. Cooling Tower Control

- Tower fan speed shall be modulated to maintain condenser water supply temperature setpoint.
- Condenser water setpoint shall be calculated based on the outdoor air wet bulb temperature plus the tower approach temperature.
 - Adjustable minimum and maximum setpoint limits shall be available.
- All active tower cells shall modulate fan speed in parallel.
- If all tower cells are off and condenser water temperature is still below setpoint, the bypass valve shall modulate open to maintain setpoint.
- All active fans shall be started and held at minimum speed prior to modulating in parallel from minimum to maximum speed.

w. Indoor Air Quality Control

- Multiple combination CO₂ transmitters shall be installed in the space served by the system and monitored via the BMS.
- In addition, a CO₂ transmitter shall be installed in the unit's main return air duct and supply air duct. The output of the installed return and space CO₂ transmitters shall be monitored by the BMS and compared to the master outdoor air CO₂ transmitter.
- The BMS shall activate an alarm if any CO₂ transmitter reading is 530 ppm (adjustable) above the outdoor air system transmitter reading.

- A DDC software program shall continuously monitor the return and space CO2 transmitters, select the transmitter with the highest reading and calculate a supply air CO2 set point, which shall be used to vary the minimum outdoor airflow set point to maintain a maximum of 530 ppm above the outdoor air system transmitter reading for all return and space CO2 transmitters.
- Minimum and maximum airflow set points shall be operator-adjustable via the workstation.
- The operator shall be capable of enabling/disabling the automatic reset at any time from the workstation.

Requirement applies to the following systems:

- Air handling units

x. Demand Response

- Heating and cooling setpoints for terminal equipment can be adjusted via global command to respond to a demand event.
- Global command shall be initiated by an operator.
- Global commands shall be isolated per building and per floor.

Requirement applies to the following systems:

- Variable air volume terminal units (both flow tracking and non-flow tracking)
- Fan powered variable air volume terminal units

G. Parts

i. Instrumentation

a. Control Valves

General (by Application)

- Chilled water valves connected directly to the campus chilled water loop shall be rated for 300 psig working pressure. Valves on the secondary side of a pressure break can be sized based on the working pressure of the secondary system.
- AHU and H&V unit hydronic heating & cooling coil valves
 - Valve type: Globe
 - Characteristic: Equal percentage
 - Seat: Single
 - Size: <2"
 - Body: Bronze
 - Trim & stem: Stainless steel
 - Connection: Threaded

- Size $\geq 2\text{-}1/2\text{'}$
 - Liquid temp. & pressure: $\leq 125\text{psig}$ @ $\leq 350\text{degF}$ or Steam pressure $\leq 100\text{psig}$
 - Body: 125 pound cast iron
 - Trim & stem: Stainless steel
 - Connection: Flanged
 - Temp. & pressure: $\leq 250\text{psig}$ @ $\leq 400\text{degF}$
 - Body: 250 pound cast iron
 - Trim & stem: Stainless steel
 - Connection: Flanged
- Valves shall have sufficient stuffing box protection to ensure against leakage at the application's hydrostatic head.
- Single-seated valves shall meet ANSI Class IV leakage (0.01% of Cv)
- Steam valves
 - Whenever the steam flow rate is such as to require a single valve larger than 2-1/2 inches, provide two (2) valves in parallel, arranged to operate in sequence.
 - Low pressure (15 psig) steam valves shall provide tight closure at a pressure at least 10 psig higher than the normal maximum operating pressure.
 - Valve type: Globe
 - Characteristic: Linear
 - Seat: Single
 - Size: $< 2\text{'}$
 - Body: Bronze
 - Trim & stem: Stainless steel
 - Connection: Flanged
 - Size $\geq 2\text{-}1/2\text{'}$
 - Pressure: $\leq 100\text{psig}$
 - Body: 125 pound cast iron
 - Trim & stem: Stainless steel
 - Connection: Flanged
 - Temp. & pressure: $\leq 250\text{psig}$ @ $\leq 400\text{degF}$
 - Body: 250 pound cast iron
 - Trim & stem: Stainless steel
 - Connection: Flanged
 - Valves shall have sufficient stuffing box protection to ensure against leakage at the application's hydrostatic head.
 - Single-seated valves shall meet ANSI Class IV leakage (0.01% of Cv)
- Combo valve & actuator for terminal unit reheat coils, 2- & 4-pipe fan coil units, perimeter radiation, chilled beams, and radiant panels
 - Valve shall be suitable for chilled and hot water service
 - Characteristic: Equal percentage, via characterized disk
 - Body: Forged Brass
 - Seat: Fiberglass reinforced Teflon PTFE
 - Ball & stem: Chrome plated brass

- Pressure rating:
 - ≤1" valve: 600 psi
 - >1" valve: 400psi
- Temperature range: 0degF - 250degF
- Leakage rating: ANSI Class IV.
- Actuator:
 - Return type: Spring
 - Power: 24VAC
 - Signal: 2-10V
 - Manual Override: Yes
 - Normal position: Closed
 - Position feedback: Yes
- Combo valve & actuator for chilled water minimum flow, modulating condenser water bypass, and inline valve applications
 - Valve type: Characterized Ball
 - Body: Carbon steel
 - Ball: 316 stainless steel
 - Stem: 316 stainless steel, blowout-proof
 - Pins & bearings: 316 stainless steel
 - Seat: Teflon
 - Leakage rating: 1/100 of Class IV ANSI/FCI 70-2
 - Actuator:
 - Return type: Fail-in-place
 - Power: 24VAC
 - Signal: 4-20mA, 0-10V, 2-10V
 - Manual Override: Yes
 - Normal position: n/a
 - Position feedback: Yes
 - Acceptable manufacturers and models:
 - DeZurik V-Port Ball
 - Jamesbury Corp. R21/23 Segmented Vee Ball
 - Flowtech or Fisher Vee Ball
- Butterfly valves
 - Valve type: High performance butterfly
 - Characteristic: n/a
 - Body: Carbon steel
 - Disk: 316 stainless steel
 - Stem: 17-4 pH stainless steel one-piece
 - Pins & bearings: 316 stainless steel
 - Seat: Teflon
 - Seal: Teflon
 - Pressure rating: Conform to application requirements
 - Connection: Lug
 - Leakage rating: Valves shall be capable of bubble-tight double dead-end closure with either upstream or downstream flange removed through the valves' full-rated pressure.

- Travel stops: Yes
- Acceptable manufacturers and models:
 - Jamesbury Corp.
 - Bray
 - Keystone K-LOK Figures 362 or 372

Execution

- All threaded valves to be installed with unions.

b. Gas Instruments

- Carbon Dioxide Combo Sensor & Transmitter

by Application:

Wall Mounted

- General
 - Output signal shall be 4-20mA for CO₂ concentration
 - Provide one calibration kit to NYULH facility management.
 - Unit shall consist of a single wall-mounted assembly designed for direct wall mounting or mounting on a standard junction box.
- Product
 - Manufacturer: Vaisala
 - Model: GMW90
- Execution
 - Mount 3' and 6' above finished floor.

Duct Mounted

- General
 - Output signal shall be 4-20mA for CO₂ concentration
 - Provide one calibration kit to NYULH facility management.
- Product
 - Manufacturer: Vaisala
 - Model: GMD20
- O₂ Monitoring System Serving MRI Equipment Rooms & MRI Rooms

General

- System to include a 4-20mA analog output.
- Oxygen monitoring system shall be a sample draw monitoring system that alerts and alarms when oxygen levels fall below safe limits for human health.

Product

- Manufacturer: ETS-Lindgren
- Model: OMS
- Sample tube shall be made of transparent polyurethane 1/4" (7 mm) in diameter.

Execution

- Wall mount, using wall mount accessory and polycarbonate case with wall-mounting accessory.
- Configure two alarms as follows:
- User-selectable relay contacts
- Fault relay for interface with the DDC system.
- Tube end shall be positioned near the ceiling of the space being monitored.

c. Flow Instruments

- Airflow Measuring Stations

by Application:

Fan Inlet Airflow Measuring Stations

- General
 - This application requires the specification of both the probe and the transmitter.
 - Transmitter shall be selected based on a span from 0 cfm to upper end of the cfm range plus 10%.
- Products
 - Probe manufacturer & model: Air Monitoring Corporation VOLU-probe/FI Pitot
 - Transmitter manufacturer & model: Air Monitoring Corporation Model VELTRON DPT 2500-plus

Outdoor Airflow Measuring Stations

- General
 - This application may require the specification of both the probe and the transmitter.
 - Probes shall not create a pressure drop in the airstream
- Products
 - Manufactures and models accepted
 - Accutrol Model IAQ-Tek
 - Air Monitor Corporation Model OAM II
 - Air Monitor Corporation Model VOLU-probe and VOLU-probe/VS w/ Air Monitor Corporation Model VELTRON DPT 2500-plus

- Thermal Flow Switch

d. Moisture Instruments

- Relative Humidity Sensor & Transmitters Combos

Product (by Application)

- Duct-mounted relative humidity sensor & transmitter combo
 - Manufacturer & model: Vaisala HMW90 Series
- Space-mounted relative humidity sensor & transmitter combo
 - Manufacturer & model: Vaisala HMD60 Series

Execution

- Sensors serving vivarium and associated support spaces to be installed in ductwork, not in space.

- Point-Type Leak Detectors

Product

- Manufacturer: Liebert
- Model: LT-410

Execution

- Sensing probes shall be adjusted to 1/8" above the floor.
- Placement of the sensing probes must consider the installed floor slope so as to detect a leak from the anticipated source(s).

- Zone-Type Leak Detectors

General

- Select cable length to provide adequate coverage per manufacturer's recommendations.

Product

- Manufacturer: Liebert
- Model: LT-460-Z##

Execution

- Install cable in a perimeter or serpentine configuration to capture leak originating from any location in or above zone

e. Pressure Instruments

- Differential Pressure Transmitters (Air)

by Application:

Static Pressure in Ducts

Flow tracking terminal units (Supply, Exhaust, Fume Hood VAVs)

- General
 - Size for unidirectional pressure range rating of at least 150-200% expected maximum nominal operating pressure. E.g. For VAV pitot sensors nominally 0-1 in-WC DP, select a 0-2 in-WC range.
 - Select Accuracy class based on criticality and operating tolerance of the application.
 - Output: 4-20mA
- Product
 - Manufacturer & model: Ashcroft CLXdp
- Static Pressure Probes (Air)

by Application:

Duct static pressure probes

- General
 - Duct static pressure measurement requires two probes, one for the measurement in the duct, specified below, and one for reference measurement. Reference pressure-sensing connections to duct static pressure transmitters shall be made through an ambient pressure probe or chamber that minimizes effects of air disturbances to maintain a stable reference pressure.
- Products
 - Manufacturer & model: Kele A-301K or A-302-K
- Execution
 - Duct wall pressure taps shall be acceptable.
 - Probe penetration into duct must be sealed to prevent air leakage.

- Pressure Sensors & Transmitters

By Application

Duct static pressure sensors & transmitters

- General
 - Duct static pressure sensor & transmitter assemblies shall consist of a static pressure probe, transmitter and electrical box for wiring connections.
 - *The static pressure probe shall extend across the width of the duct.*
 - Reference pressure-sensing connections to duct static pressure transmitters shall be made through an ambient pressure probe or chamber that shall minimize effects of air disturbances and maintain a steady, uniform reference pressure.
 - Transmitter range shall be selected to ensure that the normal set point is in the center of the device range.
 - Products
 - Probe Manufacturer & model: ?
 - Transducer Manufacturer & model: Setra Model 264
 - Execution
 - Duct wall pressure taps shall be acceptable.
- Differential Pressure Transmitters (Water/Glycol)

General

- Signal output shall be selected for 4-20mA
- Transmitter shall be enclosed in a gasketed, dust-free and water-tight housing.
- Any enclosure exposed to the process fluid shall be equipped with drain ports at the bottom and vent ports at the top with a minimum 1/4"-18 NPT
- Process fluid connection to transmitter shall be provided with a 3-valve manifold

Product

- Transmitter make/model: Rosemount Model 2051C
- Manifold make/model: Anderson Greenwood & Co. Model MDP

- Differential Pressure Switches (Air)

General

- High and low-sensing ports shall be ferrule-and-nut compression for 1/4 in OD tubing.
- All switches shall be automatic-reset type.

- Switch shall be provided with SPST NC contacts rated for 15A, 125-277 VAC.

Product

- Manufacturer: Cleveland Controls
 - Model: AFS Series
- Room Pressure Monitors

General

- Room pressure monitor shall include a bidirectional pressure sensor and wall-mounted digital interface module. Room pressure monitoring shall utilize differential pressure-sensing technology to display the respective room's differential pressure with reference to the entrance corridor.
 - Differential pressure transmitter accuracy shall be $\pm 10\%$ of reading (± 0.00001 in. H₂O) and shall be bidirectional.
- Monitors shall be provided with door sensors to disable alarms if the door is open.
 - Provide a door position switch for each door serving the room, wired in series.
- Room pressure monitor shall be designed to provide room pressure operating and alarm status, alarm indication and acknowledgment functions. Alarm set points and time delays, prior to alarming, shall be programmable. Once the alarm condition ceases to exist, the alarm and mute functions are reset automatically.
- Status indicators shall be green for normal and red for alarm. Room pressure monitoring shall include audible alarm.
- Monitor shall be provided with a silence pushbutton to deactivate the alarm horn during an alarm condition.

Product

- The following manufacturer product lines are acceptable. Match the manufacturer to existing adjacent spaces.
 - Critical Room Control
 - TSI Pressura
 - Setra Flex

Execution

- Room pressure monitor shall be located outside of room served at entrance door.
- Provide a local alarm light, horn and silence switch located within the room served. Horn and light shall be activated if a door is maintained in the open position for a continuous 3 minute time period. Silence switch shall allow the user to silence the horn; however, the light shall remain energized until the door is closed.

- If project has multiple rooms requiring pressure monitoring, monitoring shall be capable from one monitor. Multiple room monitoring only applies to auxiliary rooms not separate rooms or Operating Rooms/OR support spaces.

f. Temperature Instruments

- Temperature Sensors

General

- Where not specified elsewhere, RTD temperature elements shall be 1/10th DIN RTDs

Product

- Where not specified elsewhere, RTD temperature elements shall be manufactured by
 - ACI
 - BAPI

Execution

- Sensors serving vivarium and associated support spaces to be installed in ductwork, not in space.

- Temperature Sensor & Transmitter Combos

by Application:

Duct-mounted averaging-type

- General
 - Probe length shall be 1 linear foot per 1 square foot of duct area. If sensing probe is of insufficient length to fully cover coil area, provide multiple sensors.
 - A weather resistant electrical box shall be used to contain all wiring connections
 - Sensors for duct locations shall not be affected by vibrations encountered in normal duct systems.
- Product
 - RTD Element: ACI Model A/1K Series
 - Transmitter: Kele T85U
- Execution
 - Coil-mounted averaging sensors must be mounted as per manufacturer's recommendations.
 - Capillary shall be fastened utilizing capillary holder mounting clip (similar to Johnson Controls TE-6001-8 mounting bracket) to prevent damage to sensor and ensure appropriate radius bend where sensor changes direction.
 - Installer must coordinate the mounting hardware radius with the averaging sensor minimum radius required.

- Capillaries must be installed such that the capillary or averaging sensor can be replaced without removing multiple devices.

Preheat coil discharge sensors

- General
 - Each individual coil section shall be provided with individual temperature sensors
 - Probe length shall be 1 linear foot per 1 square foot of coil area. If sensing probe is of insufficient length to fully cover coil area, provide multiple sensors.
 - A weather resistant electrical box shall be used to contain all wiring connections
 - Sensors for duct locations shall not be affected by vibrations encountered in normal duct systems.
- Product
 - RTD Element: ACI Model A/1K Series
 - Transmitter: Kele T85U
- Execution
 - Coil-mounted averaging sensors must be mounted as per manufacturer's recommendations.
 - Capillary shall be mounted as close to the leaving side of the preheat coil without touching the coil, fins or framing.
 - Capillary shall be fastened utilizing capillary holder mounting clip (similar to Johnson Controls TE-6001-8 mounting bracket) to prevent damage to sensor and ensure appropriate radius bend where sensor changes direction.
 - Installer must coordinate the mounting hardware radius with the averaging sensor minimum radius required.
 - Capillaries must be installed such that the capillary or averaging sensor can be replaced without removing multiple devices.

Duct-mounted non-averaging-type

- General
 - Probe length shall be 18" or half the width of the duct
 - A NEMA 3R electrical box shall be used to contain all wiring connections
- Product
 - RTD Element: ACI Model A/1K-2W-D-18 Series
 - Transmitter: Kele T85U
- Execution
 - Sensors for duct locations shall not be affected by vibrations encountered in normal duct systems.

Liquid insertion-type

- Product
 - RTD Element: ACI Model A/1K Series
 - Transmitter: Kele T85U
- Execution
 - Mount sensor in a thermowell with #"-#" gap between the end of the sensor and the end of the thermowell. The void between the two shall be 100% filled with thermal grease.

- Freezestats

General

- Low-Air-Temperature Thermostats for Air (freezestats) shall be sized to provide complete coil coverage as defined below to ensure each coil has one or more dedicated switches and no two coils share a temperature switch.
 - The coil area must be covered by freezestats leaving 6 inches from each edge of the coil.
 - The maximum vertical distance between each pass of capillary shall be no more than 8 inches.
 - Switch actuation shall occur if any 12 inch length of capillary senses a temperature below set point.
 - Capillary length shall be 1 linear foot per 1 square foot of coil area.
 - If capillary is of insufficient length to fully cover coil area, provide multiple sensors.
 - If multiple freezestats are provided, each device shall only cover its percentage of coil. For example, if there are two (2) freezestats, each covers 50%. If there are four (4) thermostats, each covers 25%.

Product

- These thermostats shall be 2-position automatic-reset type.

Execution

- Capillaries must be mounted as per manufacturer's recommendations.
- Capillary shall be fastened using capillary holder mounting clips (similar to Johnson Controls TE-6001-8 mounting bracket) to prevent damage to capillary and ensure appropriate radius bends where capillaries change direction.
- Installer must coordinate the mounting hardware radius with the capillary minimum radius required.
- Capillaries must be installed such that the capillary can be replaced without removing multiple devices.
- Low-temperature shutdowns shall be manually reset via operator command from a workstation.
- The elements shall be suspended at least 6 to 8 inches downstream of the preheat coils.

- Furnish a hardwired time-delay relay to delay fan shutdown and alarming at the workstation for 180 seconds (adjustable), unless otherwise stated.

- Thermowells

Immersion temperature measurement

- All thermowells shall be type 304 stainless steel
- 3/4" NPT external thread, 1/2" NPT internal thread
- Lagging extension shall be equal to insulation thickness
- Insertion length shall be 1/3 to 3/4 of internal pipe diameter, but not more than 6"
- Thermowells shall be rated for maximum system pressure, temperature and fluid velocity.
- Internal bore of thermowells shall be sized to exactly fit the diameter of the sensing element to be installed.

g. Weather Stations

General

- For use with cooling tower or economizer control.
- Provide detail on ordering instructions to specify desired customized outputs to BAS.

Product

- Manufacturer: Viasala
- Model No.: HMS110

Execution

- Follow manufacturer's installation requirements.
- Mount in a location to minimize direct sunlight.

h. Actuators

General (by application)

- Valve Actuators
 - All two-position actuators shall be provided with open and closed limit switches for remote monitoring at the BMS.
 - Actuators shall be factory-mounted to valve body and factory-tested to ensure proper operation.
 - Actuators shall be provided with manually operated declutchable handwheels for overriding the actuator in both emergency and normal operation.
 - Actuator shall be provided with an external position indicator.
 - Tandem-mounted actuators are not acceptable.
 - Actuators, limit switches, manual override handwheels, position indicators, etc., that are located outdoors shall be constructed for

outdoor use. All electrical devices shall be weatherproof and NEMA 4-rated. All exposed valve components (i.e., stem, shaft, gear operators, handwheel, etc.) shall be constructed of non-rusting metal or factory-coated with rust-inhibiting paint.

- Damper actuators serving automatic louver dampers
 - Tandem-mounted actuators shall not be provided
 - Housing shall be NEMA 2
 - Manual override shall be provided
 - Include external direction of rotation switch
 - Ambient temperature operation shall be -22°F to 122°F
 - Storage temperature shall be -40°F to 176°F
 - Actuators shall be UL-listed
 - Two Position
 - Actuators in two-position (open/closed) service shall be 120 VAC electrically actuated spring-return type. Spring-return running time shall not exceed 20 seconds.
 - Modulating
 - All automatic louvered damper actuators in modulating service shall be either 120 VAC or 24 VAC electrically actuated spring-return type, and shall be fully proportioning, unless otherwise specified. Spring-return running time shall not exceed 20 seconds.

Product

- Valve Actuators
 - Acceptable manufacturers: Bray, limitorque, EIM
- Louvered Damper Actuators
 - Acceptable manufacturers: Belimo
- Control Valve Actuators

Preheat coil

- Return: Spring
- Power: 24VAC
- Signal: 4-20mA, 0-10V, 2-10V
- Manual Override: Yes
- Normal Position: Open

Steam-to- or water-to-water heat exchanger

- Return type: Spring
- Power: 24VAC
- Signal: 4-20mA, 0-10V, 2-10V
- Manual Override: Yes
- Normal position: Closed

Chilled water coil

- Return type: Spring
- Power: 24VAC
- Signal: 4-20mA, 0-10V, 2-10V
- Manual Override: Yes
- Normal position: Closed

Reheat coil

- Return type: Spring
- Power: 24VAC
- Signal: 4-20mA, 0-10V, 2-10V
- Manual Override: Yes
- Normal position: Closed

i. Current Instruments

- Current Sensing Switches

General

- Switches shall have field adjustable sensitivity for detecting AC current levels.
- Relay contacts shall be Form C-rated for 5A at 120VAC

Execution

- For belt-driven equipment, relay shall be adjusted to detect a belt break.
- Relay shall be installed on one lead of the load side of the motor feed.

j. Signal Transducers

i. Relays

Time Delay Relay

- General
 - Time delay trigger and function shall be specified to meet the application requirements.
- Product
 - Manufacturer: Magnecraft
 - Model: TDR

Plug-In Terminal (Ice Cube)

- General
 - Relays shall be plug-in terminal type with a DPDT configuration
 - Contact material shall be silver cadmium oxide
- Product
 - Manufacturer: Idec
 - Model: RH Series

- Execution
 - Each safety device serving a fan system shall be wired to a 2-pole relay located in the controller enclosure. One pole normally open of the relay shall be wired as a digital input to the controller serving the fan system identifying the specific alarm. The second pole, normally closed, shall be wired in series with the second pole of the relays serving other safety devices.

Self-Enclosed Relay (Relay in Box)

ii. Networks

a. Network Hardware

- Switches

General

- Quantity of 10 gigabit ports is required
- A minimum of 24 ethernet ports is required. For large buildings, 48 ports is preferred.
- Switch must include redundant hot-swappable power supplies

Approved Products

- Manufacturer: Juniper
 - Model: EX-2300 or EX-3400
- Manufacturer: Netgear
 - Model: Netgear Pro Series
- Manufacturer: Blackbox
 - Model: Gigabit Managed LG8 Series
- Manufacturer: Cisco
 - Model: Catalyst 9500

- Routers

General

- BACnet router between MS/TP and B/IP (BACnet over IP) as well as a BBMD (BACnet Broadcast Management Device) for transportation of BACnet broadcasts over an IP network with several subnets.
- Routers shall comply with the latest version of ASHRAE Standard 135 for communications.
- Routers shall be UL864 listed when connected to BACnet MS/TP network segments that contain UL864 listed devices being used in a smoke control application.

- Device shall be capable of routing BACnet packets over Layer 3 IP network and shall support both the router and BBMD networking options. BBMD shall support registration of Foreign Devices.
- Devices shall be password protected with additional security settings.

iii. Piping & Panels

a. Panel Enclosure

General

- The enclosure shall be made of steel or extruded aluminum with proper bracing for rigid wall or floor mounting. The enclosure shall not be attached to any piece of building equipment. All associated controller equipment shall be mounted in this enclosure such as controllers, power supplies, relays, switches, etc.
- Hinged door shall contain a key-operated lock. Lock shall be a cam style, in order for all the cores to be accessed via a master key.
- Enclosures shall have a removable perforated backplane where all devices, din rail, and Panduit shall be secured and mounted.

Product

- Enclosures located within the building and not subject to outdoor environmental conditions shall be NEMA 12.
- Enclosures subject to outdoor environmental conditions shall be NEMA 4X with thermostatically controlled ventilation fan and electric heater.
- Accepted panel manufacturers:
 - Unity
 - Hoffman
 - Hammond

Execution

- All conduit penetrations to enclosures shall be sealed by utilizing duct seal putty as manufactured by Rainbow Technology.
- All conduit penetrations to enclosures shall be from the bottom or sides to prevent any liquids from draining into the panel.

b. Terminal Block

General

- All control panels shall be provided with a terminal strip for field wiring

Product

- Terminal blocks shall be 300 volt rated, medium duty, channel-mounted, with numbered marking strips.

c. Labeling

General

- Provide an engraved nameplate for each enclosure, mounted on the face of the door, indicating the controller tag, device instance, system served and branch circuit number and electrical panel tag from which the enclosure is fed.
- The control panel has to be labeled for all the components, such as the circuit breakers, strip terminal blocks, control relays, transformers, power supplies, and controllers. All internal wires between the input and output from the controller and the terminal block have to be labeled. All labeling of controller devices, controllers, transformers, relays, wire, tags, etc. shall match labeling on approved as-built drawings
- Each control device (IE. Relays, fuses, etc.) mounted within enclosure shall be marked with a nameplate cross-referencing it to the control diagram.
- Wiring shall have identification sleeves at each termination at the terminal strip individually identified per control/interlock drawings, with adequate clearance for field wiring.

d. Panels

General

- Enclosures shall be provided with space for future addition of instruments. Fully loaded enclosures shall not be acceptable. Enclosures shall be oversized by 25%.
- Separate terminal blocks shall be installed for 120 volt AC wiring and for low-level signal wiring within enclosures. Terminal blocks for line voltage wiring shall be separated from low-level signal wiring by a barrier partition.
- Each enclosure shall be provided with a plastic sleeve located on the inside of the door, which shall be used to contain “as-built” control diagrams serving the respective system. Plastic sleeve to contain controller directory indicating all input and output points labeled as per “as-built” drawings.
- Provide a 120 volt, 60 hertz duplex convenience outlet within each enclosure. Convenience outlet shall be provided with dedicated circuit breaker protection 5 Amp max.

Execution

- Interconnections between internal devices and field wiring shall be installed at terminal strips

- All wiring shall be contained neatly within plastic conduit.
 - Low voltage and line voltage wiring shall be routed through separate conduits.
- Enclosure shall be provided with all required transformers and a main circuit breaker to disconnect all power serving the enclosure.
- All transformers shall be mounted within an enclosure. Transformers will not be permitted to be installed out of enclosures.
- For pressure switch alarms, provide a manual reset pushbutton switch with indicating light mounted on the face of the enclosure door.
 - Pushbutton shall allow an operator to reset a pressure alarm. The system shall remain off until manually reset via the pushbutton.

a. Control Panel

All materials used for the control panel must be UL - listed and wired up under the standards of the National Electrical Code.

The BMS subcontractor must include detailed panel control layout in the submittal drawings, including all associated devices such as controllers, circuit breakers, power supplies, transformers, relays, terminal blocks, wire ducts, and labels. See figure CPL-01 for references. If the control panel has an external power source, see Figure CPL-04 as a reference.

The Control Panel must consider the following points:

- Circuit Breaker (CB)

The control panel must have a main circuit breaker (CB) whose label will be: CB-MP. This CB must be selected according to the total load that will be used in the control panel; see figure CPL-01A for a power diagram.

- Power Supply (PS)

If power supplies are used to feed 24 VDC to the controllers, the power supply must have a circuit breaker in the primary circuit and another circuit breaker in the secondary circuit. The CB must be selected according to the amperage necessary to protect against overcurrent. See Figure CPL-01A for the power diagram.

- Transformers (TX)

Each 120 / 24 VAC transformer used in the control panel must have a circuit breaker in both the primary circuit and another circuit breaker in the secondary circuit. The CB must be selected according to the amperage necessary to protect against overcurrents. See Figure CPL-01A for a power diagram.

- Single Terminal and double level terminal block
 - i. Single terminal block

Use single-terminal blocks for the 120 VAC main power supply connections to the control panel as well as the low-voltage connections after the power supply and transformers. See Figure CPL-02 for details of the terminal block and circuit breakers for 120 VAC (TB-P1) and for low voltage 24 VAC and 24 VDC (TB-P2), and Figure CPL-1A for a wire diagram reference.

- ii. Double level terminal block

Inputs and Outputs:

All the signals from the field devices must be connected to these terminals. There should be a strip of double-level terminal blocks for inputs and a strip of double-level terminal blocks for the output signal for the field. See Figure CPL-03 - TB-01 as references. The top level has an odd number for a positive signal, and the bottom level has an even number for a negative signal.

Field Power devices:

A double-level terminal block strip; check terminal block TB-FPW shown in figure CPL-03 to feed 24 VAC to the field devices. Minimal of two double terminal block for 24VAC (T3) blue color and two double terminal block for COM (T4) yellow color.

- Layout Spaces

The control panel has to consider the following table for the minimum and maximum space to install the DIN rail that holds the terminal block strip, circuit breaker, control relays, and controllers, as shown in figure CPL-01 as a reference.

Reference	Inch	
	MIN	MAX
A	5	5.5
B	5	6
C	1	2
D	1	2
E	5	5.5

- Labels

The control panel has to have labels for all the components, such as the circuit breakers, strip terminal blocks, control relays, transformers, power supplies, and controllers. All internal wires between the input and output from the controller and the terminal block have to have wire labels.

- Wire duct

The control panel layout drawing has to indicate the width and height of the wire duct (Panduit), as shown on Figure CPL-01 as a reference. The wire duct has to be selected according to the manufacturer's recommendations.

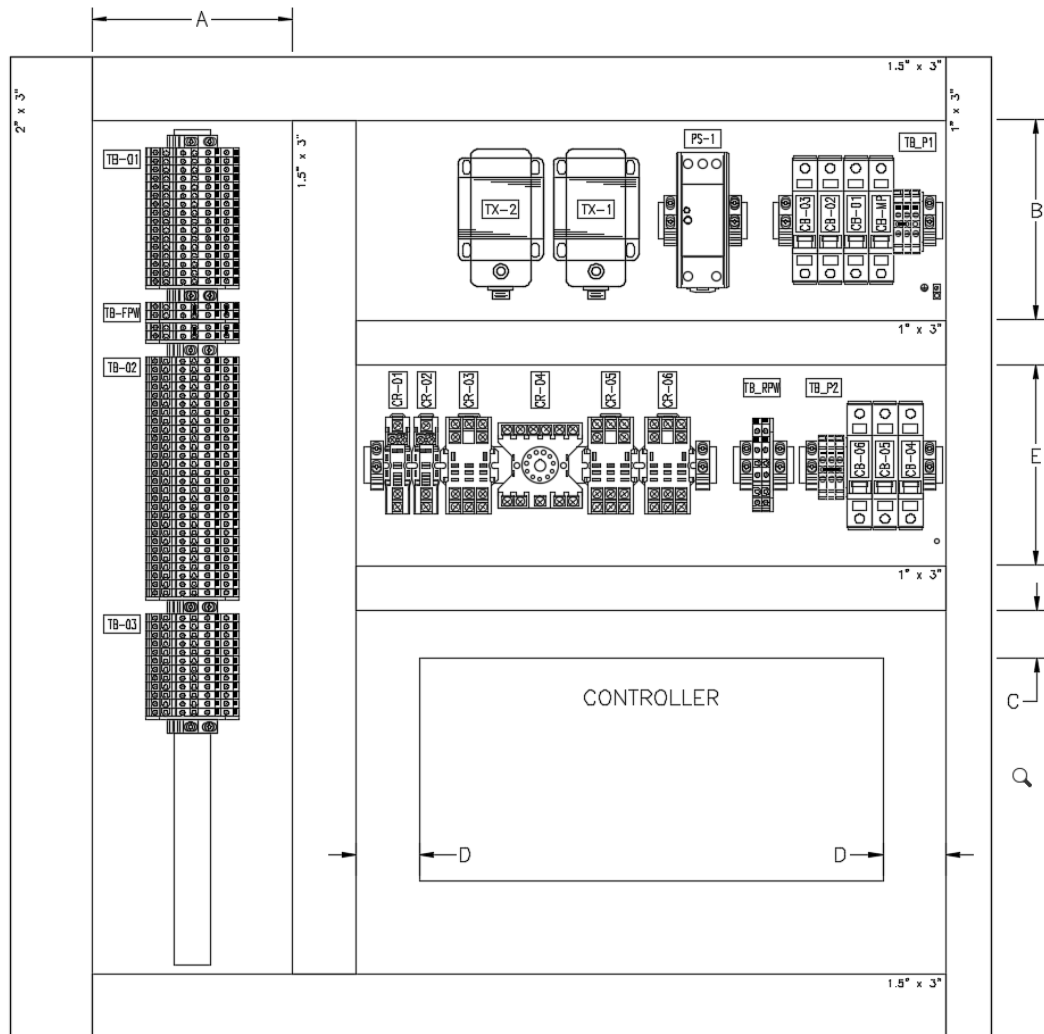

Figure: CPL-01

Reference	Inch	
	MIN	MAX
A	5	5.5
B	5	6
C	1	2
D	1	2
E	5	5.5

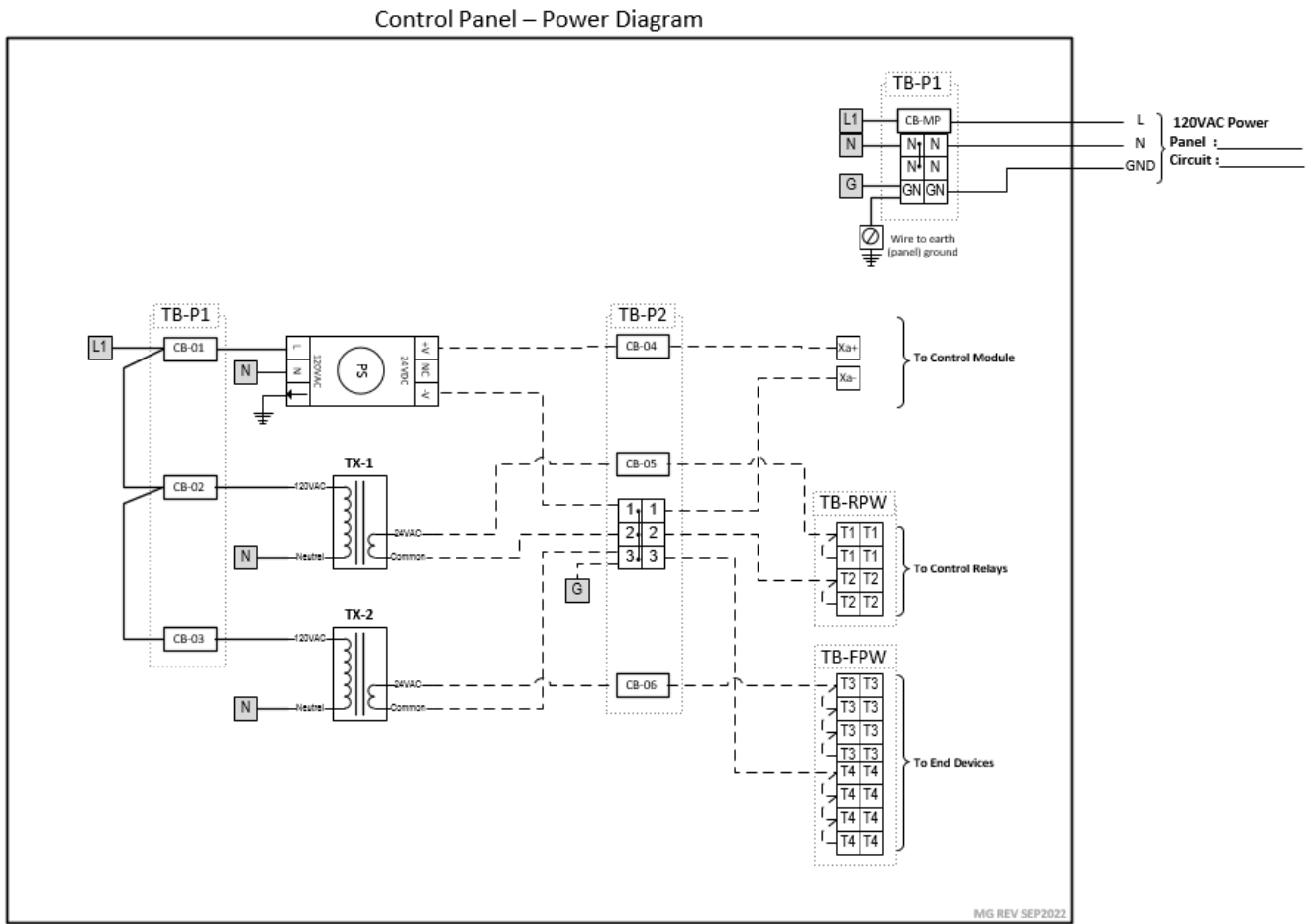

Figure: CPL-01A

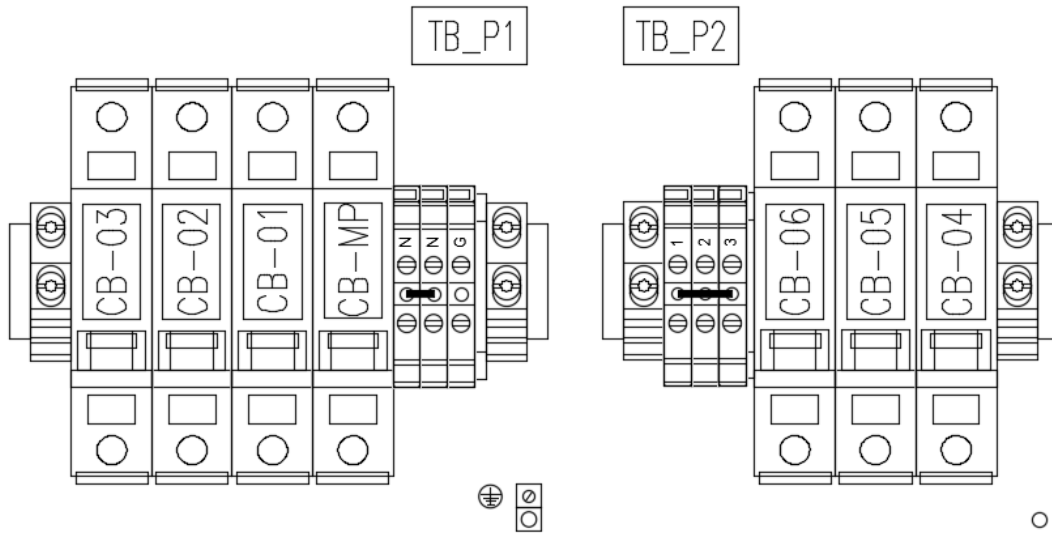

Figure: CPL-02

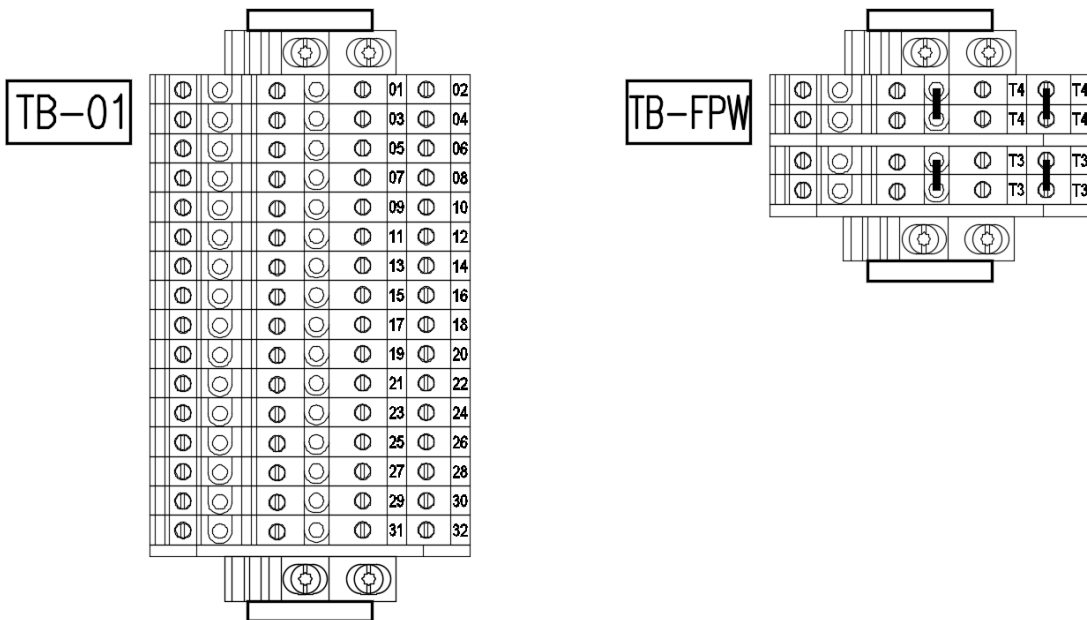

Figure: CPL-03

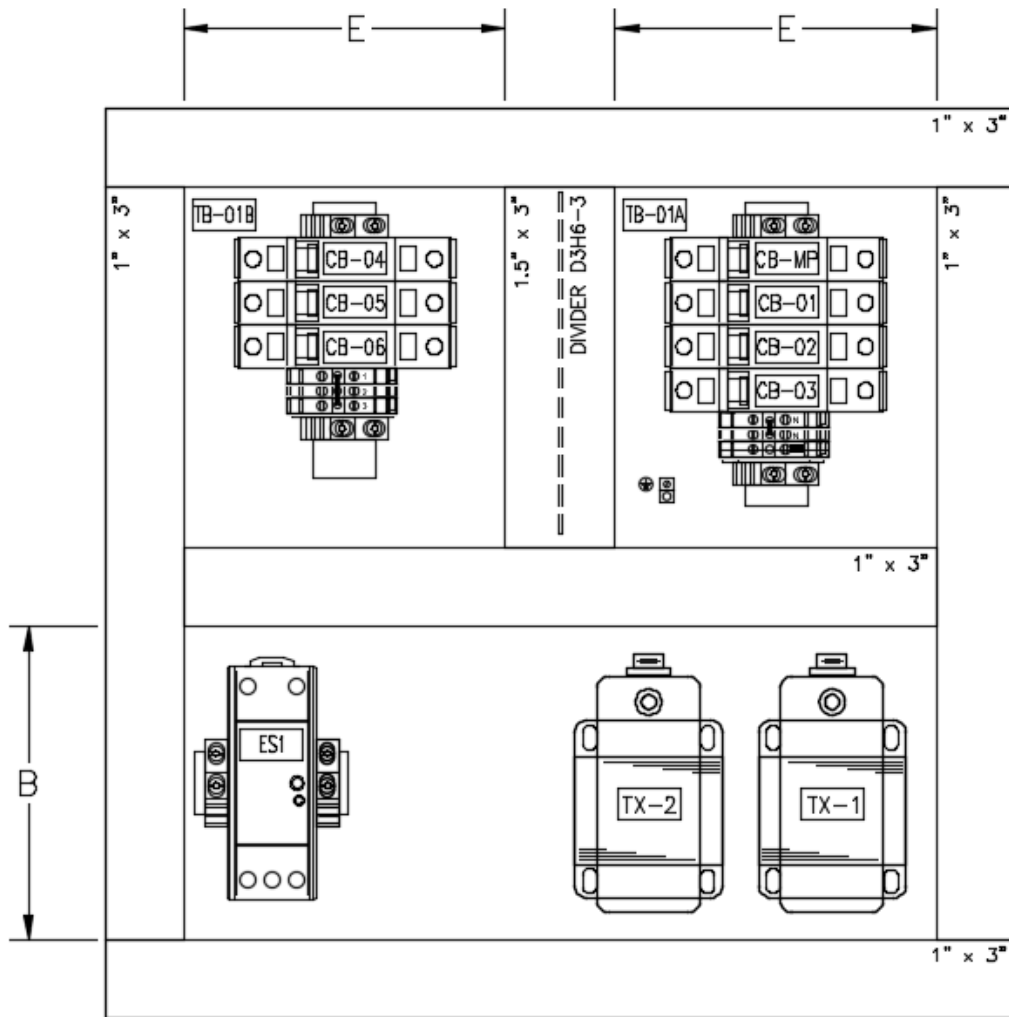

Figure: CPL-4

Reference	Inch	
	MIN	MAX
B	5	6
E	5	5.5

iv. Power

Systems & Equipment (AHU's, Chillers, etc.) fed from emergency power sources shall have their associated DDC controllers and DDC devices fed from the same emergency source.

All control power, 24V or otherwise, shall be protected with a line filter, surge suppressor, electrical breaker, and control fuse (last two need discussion).

a. Control Transformer

General

- Transformer shall be sized as follows for optimal performance and overheat issues.
 - Control Panels: Total VA of all controllers in the panel on the same power loop x 1.5 = Transformer size
 - Controllers with actuator: Total VA of all controllers and actuators on the same power loop x2 or x3 based on total devices = Transformer size

Product

- Manufacturer: Functional Devices, Inc.
- Models:
 - 50VA Part No.: TR50VA005US
 - 75VA Part No.: TR75VA005
 - 100VA Part No.: TR100VA005

b. Uninterruptible Power Supply for Network Hardware

General

- The UPS shall be monitored at the nearest network switch via an IP network wire in conduit.

Product

- Manufacturer: Schneider APC
- Model: SUA500PDRI-H

Execution

- Ensure UPS is wired as per manufacturer's specifications.

v. Wire

General

- All wiring to be in accordance with manufacturer requirements, local and national electric codes, and latest NYC Building Code.
- Cables for 120/24 VAC wiring, communications wiring and low-level signal wiring (i.e., 4-20ma, 0-10v) shall always be run in separate raceways.
- Open wiring strung above accessible ceilings shall be plenum-rated cable.
- All wiring in Mechanical Equipment Rooms, communications or electrical closets shall be in approved raceway (conduit, EMT, etc.).

- Wiring within inaccessible ceilings shall be installed in conduit.
- Wiring within drywall cavities or enclosure or beneath raised floor construction shall be in conduit.
- The supporting of wiring from other equipment, mechanical ductwork or piping shall not be acceptable. Provide individual supports for conduit and free air plenum cable.
- No 300 volt insulated (rated) wiring shall terminate within or occupy any enclosure containing conductors operating at a voltage greater than 300 volts. This particularly applies to any analog or digital I/O wiring entering 460 volt motor starter enclosures or motor control centers.
- Wire jacket colors shall comply with the Wire Jacket Color Requirements.
- Wire jacket/insulation must be compatible with duct seal putty.
- BMS conduit color labelling shall be Orange background with Black lettering

BMS	Black on Orange	TEXT
-----	-----------------	-------------

Products

- See subsections for product requirements

Execution

- Open wiring strung above accessible ceilings shall be bundled together and protected from mechanical damage.
- Wiring shall be independently supported from the building structure with bridal rings and clips.
- All control wiring internal to the panel shall be wired from the I/O of the controller to the terminal strip. Under no circumstance will field wiring be terminated from inputs or outputs directly to the controllers.
- Terminations shall be mechanically and electrically secure. Twist-type wire nuts shall not be acceptable. Insulated tinned copper lugs shall be provided.
- Perform continuity and point to point testing for all wiring installed.
- Wire stripping and terminations shall follow the correct installation procedure as shown below:

CAUTIONS

- Do not allow more than .125 inch (.3 cm) bare communication wire to protrude.

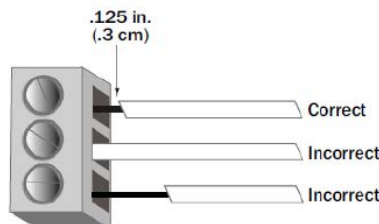

- If bare communication wire contacts the cable's foil shield, shield wire, or a metal surface other than the terminal block, communications may fail.

a. Analog & Digital Signal Wire

General

- Wire jacket/insulation shall be compatible with duct seal putty.

Product

- 3-Conductor Shielded
 - Manufacturer: Windy City Wire, Inc.
 - Model: 2335# - the last digit(s) indicates the color
- 2-Conductor Shielded
 - Manufacturer: Windy City Wire, Inc.
 - Model: 232# - the last digit(s) indicates the color

b. IP Network Wire

General

- All CAT 6 cable runs shall not exceed 100 meters in length.

Product

- Manufacturer: Belden
- Model: 7882A D151000

c. Non-IP Network Wire

General

- This section applies to cabling used in the following applications
 - ARC156
 - MS/TP Networks
 - Modbus RTU

Product

- Manufacturer: Windy City Wire, Inc.
- Model: 043006AL-S

d. Power Wire

See NYU Langone Health Electrical Design Guidelines for power wire requirements at voltages equal to and above 120 Volts.

e. Wire Labels & Labeling

General

- All wires terminating at each field device, terminal box, field equipment cabinet, DDC control unit, or any other terminals shall be identified by labels.
- Identification shall be consistent with the tagging indicated on the approved shop drawings.

- All communication wiring shall be tagged with the previous and post devices on the network.
- The same identification code shall be carried through from the field device to the final termination point.

Product

- Brady clip sleeve-type non-metallic wire markers or equivalent.

Execution

- After identification is complete, the wire markers shall be anchored using a single layer of non-yellowing clear Mylar tape.

H. Smarts

i. Alarms

General Requirements:

- All digital input points shall be alarmed on change of state from normal state. Include a 60 second time delay on make unless specified in Alarm Parameters.
- All analog input points shall be alarmed. Provide adjustable deadband to prevent nuisance alarms. Include a 300 second time delay on make and appropriate deadband unless specified in Alarm Parameters.
- Nuisance alarms (i.e., repeating alarms) will be corrected during warranty period. Nuisance alarms are considered alarms that repeat due to poorly configured alarms or if smart alarms are not installed and cause unnecessary lower tier alarms.
- All systems that are capable of automatic restart after a shutdown/alarm condition shall be able to have remote alarm clearing and acknowledgement ability through the BMS. Local clearing of alarms shall only be necessary with systems that can only be reset locally.
- For projects on the Manhattan Main Campus and Long Island Main Campus, alarming shall be integrated in to Virtual Facility Alarm Triage.

Smart Alarming:

- Smart alarming feature shall be implemented when an equipment failure will trigger multiple secondary alarms causing unnecessary data transmission and operator alarm acknowledgement. Smart alarming shall be utilized to prevent unnecessary alarming of points.
- Smart alarms shall be implemented for the following systems:
 - Air handling units
 - Chilled, condenser and hot water systems
 - Secondary water systems
 - Rooms that are monitored via door contacts and room pressure monitors
 - The following are some examples:
 - Air Handling Unit Run Failure

- On failure of an air handling unit to operate when commanded on or air handling unit shut down due to a safety device, or if an air handling unit is off, provide a software program which shall disable all alarming capability of each temperature, pressure and humidity sensor associated with the air handling unit.
- On failure of an air handling unit to operate when commanded on, an alarm should trigger for the fan status loss, but no pressure sensor alarm or supply air temperature alarm or normal room temperature alarms.
- On failure of an air handling unit with more than one (1) fan, one (1) alarm shall generated for failure. All individual fan fail alarm will disabled.
- All VAV boxes or other terminal units reliant on airflow from the AHU will have their alarms disabled upon air handling unit failure to run or has not proven status.
- All safety devices (pressure switches and freezestats) shall remain active and capable of alarming.
- In general, space temperature alarms in areas served by the air handling unit shall be disabled. However, extreme room temperatures or freezing preheat temperatures should annunciate (Note: There may be critical rooms such as cold rooms which will continue to be monitored for alarm.)
- All space pressurization alarms in areas served by the air handling unit shall continue to be monitored for alarm.
- Upon a smart alarm activation, the alarm message must read that this is a smart alarm and some alarms have been suppressed.
- Note: Alarms associated with critical areas shall not be included within smart alarming programs. Alarms include Cold Rooms, Animal Holding Rooms, Patient Isolation Rooms, etc. Verify all smart alarming functions with NYULH facility management prior to implementation.
- Secondary Water System Failure
 - On failure of all pumps associated with a secondary water system, provide a software program that shall disable all alarming capability of each temperature, pressure and flow sensor associated with the water system.
 - All alarms associated with equipment that is disabled (i.e., off) shall be inhibited from operating.
 - When a piece of equipment is off, all alarms associated with the equipment, as well as alarms associated with areas served by the equipment or secondary equipment served, shall be disabled.
 - Note: Alarms associated with critical areas shall not be included within smart alarming programs. Alarms include Cold Rooms, Animal Holding Rooms, Patient Isolation Rooms, etc. Verify all smart alarming functions with NYULH facility management prior to implementation.

- Filter Alarm
 - All filters shall be provided with a differential pressure transmitter that shall be monitored at the BMS. Dirty filter alarms shall be generated when the differential pressure across the filter has exceeded setpoint (adj.). Filter alarms based off runtime are not acceptable.

Alarm Parameters:

- Alarm parameters shall be structured as follows:

Alarm	Delay on Make (seconds)	Delay on Break (seconds)
Multiple Fan Array Fail - Individual	3600	60
Multiple Fan Array Fail -Unit	300	0
Single Office Fan Fail	600	0
Single Lab Fan Failure	300	0
Single Critical Fan Failure	60	0
Pump Failure	60	0
Fan/Pump VFD Common Alarm	1800	600
Fan Filter	84600	3600
Fan Temperature	600	60
Fan/Pump Pressure (Static/DP)	300	60
Fan AirFlow	7200	3600
VAV Room Temperature	600	60
VAV AirFlow	3600	600
Leak Detector	60	10
Freeze Detector	60	10

Alarm Syntax:

- Alarm syntax shall be structured as follows:
 - Priority Designation, Critical, Building, Floor, System, Alarm, Contact Shop
 - Example: **** Critical Tisch 18th Floor AHU-4 Supply Fan Failure Alarm
Contact Energy Shop
- Return to Normal syntax shall be structured as follows:
 - Return to Normal (Priority Designation, Critical, Building, Floor, System, Alarm)
 - Example: Return to Normal (**** Critical Tisch 18th Floor AHU-4 Supply Fan Failure Alarm)
- Priority Designation:
 - ***** 5 Star Alarms:
 - Animal Facility/Vivarium-Related Alarms
 - Animal Facility/Vivarium Fan failures, Reheat Systems, Steam Systems
 - Critical Labs - ABSL-3 Fan Failures, Space Temp/Humidity, Reheat Systems, Steam Systems
 - Critical Fan Failures Affecting Operating Room, Isolation Rooms, Protective Environment Rooms (Fans include air handling unit supply, return, and exhaust fans)
 - Emergency Power-Related Alarms
 - Medical Air System Alarms
 - Compressed Air Systems
 - Procedure Rooms Alarms
 - Data Center Alarms
 - **** 4 Star Alarms:
 - OR Temperature and Humidity Alarms
 - OR Fan System Failures
 - OR Reheat System Alarms
 - Sump Pit Overflow Alarms
 - Ejector Pit Overflow Alarms
 - *** 3 Star Alarms:
 - Vacuum System Alarms
 - General Reheat and Perimeter Space Alarms
 - General Lab Fan Failure Alarms
 - Sump Pit Alarms
 - Ejector Pit Alarms
 - Walk-In Box Alarms
 - ** 2 Star Alarms:
 - Office Fan Failure Alarms
 - General Lab Temperature and Humidity Alarms
 - General Lab Airflow Alarm
 - Non-Critical Alarms:
 - Office Temperature and Humidity Alarms

- Critical vs. Non-Critical:
 - The designation “Critical” shall be included in the alarm syntax only for 2, 3, 4, and 5 star alarms. For all other alarms not listed above, the designation “Non-Critical” shall be used.
- Building Abbreviations (for NYULH Main Campus):
 - Alumni Hall - ALH
 - Berg - BRG
 - Coles Student Laboratory - Coles
 - Energy Building - EB
 - Greenberg Hall - GBH
 - Medical Science Building - MSB
 - Millhauser - Mil
 - Tisch Hospital - TH
 - Schwartz Health Care Center - HCC
 - Science Building - SB
 - Skirball Institute - Skirball
 - Smilow Research Center - SRC
 - Kimmel Pavilion – KP
- Floor:
 - Identify floor where alarm is active (e.g., 2nd Floor, Lobby, roof)
- System:
 - Utilize equipment tag or designation (e.g., AC3-7, AHU-TH-18-1, Walk-In Box Room 225, Filtration Water Holding Tank)
- Alarm:
 - Identify actual device in alarm (e.g., Cooling Tower Trip Alarm, Fan Failure Alarm, Common Alarm, High Humidity Alarm).
- Contact Shop:
 - Energy Shop
 - All BMS-Related Communication Alarms and Outages
 - All BMS AHU, VAV, HW System Alarms (Energy to Reassign Post-Control Signal Confirmation/Verification)
 - All BMS AHU Humidity Alarms (Dual Assignment - HVAC Shop)
 - All Room Pressure-Related Alarms (Dual Assignment - HVAC Shop)
 - HVAC Shop
 - All CHW FCU-Related Alarms
 - All Pneumatic-Related Alarms
 - All HVAC (AHU, FCU) Filter-Related Alarms
 - All Room Pressure-Related Alarms (Dual Assignment - Energy Shop)
 - All Low and Medium Steam Pressure Alarms, including HW System DP Alarms
 - All AHU-Related Humidity Alarms (Dual Assignment - Energy Shop)
 - Building Engineers
 - All CHW Plant-Related Alarms - Building to reassign these alarms when applicable
 - All Fire System Alarms
 - All Fuel Oil System Alarms (Dual Assignment - House Electricians)

- All High Steam Pressure Alarms
- All Generator-Related Alarms (Dual Assignment - House Electricians)
- All Sump Pit-Related Alarms (Dual Assignment - Plumbing Shop is Primary)
- Plumbing Shop
 - All Sump Pit-Related Alarms (Dual Assignment - Building Engineers: Secondary)
 - All Pump-Related Alarms (Dual Assignment - Building Engineers: Secondary)
 - All Medical Air System Alarms
- House Electricians
 - All Generator-Related Alarms (Dual Assignment - Building Engineers)
 - All Fuel Oil System Alarms (Dual Assignment - Building Engineers)
 - All Power-Related Alarms
- Refrigeration Shop
 - All DX AC/AHU-related Alarms, including DX FCU's
 - All Walk-In Box Alarms
 - Refrigeration system cooling towers
- Note: The term “dual assignment” means two (2) “shops” are assigned to these alarms.

Infection Prevention and Control (IPC) and Nursing

- The BMS shall automatically generate alarms, via e-mail to IPC and Nursing based on operating room humidity levels and pressurization level. E-mail addresses shall be provided by the Facility Management Team.
- Operating Room Humidity Alarms (Typical per Operating Room)
 - On sensing a humidity level either below 30% RH or above 60% RH, the system shall annunciate an alarm at the operator workstation.
 - If the humidity level continues to remain either below 30% RH or above 60% RH for an additional 30 minutes (i.e., a total of 60 minutes from original alarm), an email alarm shall be automatically sent to IPC and Nursing.
- Operating Room Pressurization Alarms (Typical per Operating Room)
 - On sensing a neutral or negative pressurization level, the system shall annunciate an alarm at the operator workstation. Note: Entrance door must be closed for a minimum of 2 minutes prior to issuing alarm. Alarm to be disabled if door is open.
 - If the pressurization level continues to remain neutral or negative for an additional 30 minutes (i.e., a total of 60 minutes from original alarm), an e-mail alarm shall be automatically sent to IPC and Nursing.
- Protective Environment Room Pressurization Alarms (Typical per Isolation Room, Central Sterilizer, Bone Marrow, Air Locks, Vestibules, BSL3 Labs, etc.)
 - On sensing a neutral or negative pressurization level, the system shall annunciate an alarm at the operator workstation. The respective NYULH shop will be required to respond within 30 minutes. Note: Each door serving the

room must be closed for a minimum of 2 minutes prior to issuing alarm. Alarm to be disabled if door is open.

- If the pressurization level continues to remain neutral or negative for an additional 30 minutes (i.e., a total of 60 minutes from original alarm), an e-mail alarm shall be automatically sent to IPC and Nursing.

ii. Trends

General Requirements:

- Trends shall be established for each hardwired and software-generated point associated with a system. For each project, trends shall be identified as critical or non-critical trends by the Facility Management Team.

Trend Point Collection:

- Each trended point shall be supported by collection point hardware capable of storing a minimum quantity of trend samples for each point before any samples are overwritten. Where controllers do not have this capability due to either the number of trended points or inability to store trends, provide additional controllers to provide the required trend storage and memory capabilities.
- Transmission between the point of collection device (DDC controller) and the trend storage device is critical. Each trend shall have its buffer size (the value at which the controllers sends its stored trend data to the collection software) set to a value equal to the smaller of either four (4) times the trend rate (i.e., the amount of samples per hour) or a maximum quantity of samples which. Under no circumstances shall the buffer value be set to more than the maximum quantity of samples.
- Each time the buffer reaches its sample limit, the entire volume of software samples stored in the controller shall be sent. The collection software shall review the data and eliminate duplicate values (i.e., previous values already sent which have been successfully received at the collection software).
- Critical trends shall have a software routine included (separate from the “standard” trending software) that regularly monitors the trend data and alerts the user when expected trend data has not been received. For each trend, provide a software routine that shall monitor the last received trend point’s time stamp and identify when it has “aged” sufficiently to generate an alarm. Aging limit shall be exceeded when the last data point in the trend has a time stamp which is greater than two (2) times the value of the buffer size divided by the trend rate. This software routine cannot reside in the DDC controller which is the collection device for this data set.

Analog Trend Points:

- The following analog type points shall be trended based on an adjustable time interval or change of value passed a percentage of the sensor’s maximum value:
 - Space temperature

- Non-critical space: 5 minute interval as standard
 - Critical space: Change of value every 1 °F or 0.5°C
- Space differential pressure
 - Change of value every 5% of setpoint (e.g. record COV every 0.05 in. change of a space with a 1 in. setpoint)
- Air handling unit supply, return, mixed-air and preheat coil discharge air temperature
- Change of value every 5% of setpoint Air handling unit supply and return air humidity
 - Change of value every 5% of maximum value (100%rh)
- Air handling unit supply, return and outdoor airflow rates
 - Change of value every 5% of setpoint
- Duct static pressures
 - Change of value every % of setpoint
- Water temperatures
 - Change of value every 5% of setpoint
- Water systems differential pressure
 - Change of value every 5% of setpoint
- Water flow rates
 - Change of value every 5% of setpoint
- Btu meters (5 minutes as standard)
- Set points, associated process variables and control signals (Note: sample rate based on variables listed above)
- UPS voltage per phase, current per phase, kW input and kW output
- PDU voltage per phase, current per phase, kW input and kW output
- Distribution board voltage per phase, current per phase, kW output

Digital Trend Points:

- The following digital-type points shall be trended based on an adjustable time interval:
 - Run status (e.g., pump, fan, air conditioning unit, chiller, etc.) (10 minutes as standard)
 - Safety device (e.g., pressure switch, freezestat, leak detector, etc.) (10 minutes as standard)
 - Dry contact input from third-party equipment such as packaged air conditioning unit common alarm contact (10 minutes as standard)
 - Door contact associated with room pressure monitors (10 minutes as standard)

Controller Data Trend Points:

- The following status/data points shall be trended based on change of state:
 - Controller online/offline status
 - Controller reboot

iii. Instrumentation

a. Actuator Engineering

Valve Actuators

- Hydronic control valve actuators shall be sized to close against a differential pressure equal to the design pump head plus 10%.
- Actuators shall be sized based on valve operating torque values and safety factors stated by the valve manufacturer as well as the maximum torque developed during the stroke of the valve when operating under maximum working conditions. Actuators shall be of sufficient torque to smoothly position valve disk to maintain specified leakage classification.

Louvered Damper Actuators

- Actuator mounting arrangement shall be outside the airstream.
- Wherever possible, actuators shall be direct-coupled type, which require no crank arm and linkage, and shall be capable of direct-mounting to a jackshaft. In applications where it is not feasible to direct-mount couple actuators to damper shaft or jackshaft, provide a substantial (strong) linkage between the actuator and damper.
- Actuator linkage arrangement shall be such as to permit normally open or normally closed positions of the dampers as required.
- Temperature Instruments
- Temperature Sensor & Transmitter Engineering
- Each individual coil section shall be provided with individual temperature sensors.
- Where multiple sensors are required for a single coil section, a DDC software program shall “average” the multiple sensors.

b. Control Valve Engineering

- Control valves shall be sized using the following basic formulas:

Sub-Critical Flow

$$\text{Liquid: } CV = Q \sqrt{\frac{GF}{\Delta P}}$$

$$\text{Steam: } CV = \frac{W}{2.1\sqrt{\Delta P(P1 + P2)}}$$

Critical Flow For Steam: ($\Delta P > P1/2$)

$$CV = \frac{W}{1.65P1}$$

- CV = Valve flow coefficient
- GF = Specific gravity at flowing temperature (water = 1 @ 60°F)
- P1 = Upstream pressure, psia
- P2 = Downstream pressure, psia
- ΔP = Actual pressure drop P1 - P2
- Q = Liquid flow rate, US gpm
- W = Steam flow rate, pounds per hour

c. Temperature Sensor Engineering

- Each individual coil section shall be provided with individual temperature sensors.
- Where multiple sensors are required for a single coil section, a DDC software program shall “average” the multiple sensors.
- Manufacturer’s standard thermistor temperature-sensing elements are only acceptable for use serving space temperature monitoring of VAV terminal units.
- The use of thermistors shall not be acceptable for other air and water applications.

iv. Networks

a. RS-485 Networks

- Communication loops shall always be daisy chained in a line topology and shall not be T-tapped or spliced in anyway
- Unique MAC address and Device ID for each controller on the network.
- A repeater after every 31 devices or after 2000 feet (whichever is reached first), and at each brand of a network comprised of multiple manufacturers/product types

- Have one of the following in order to prevent signal distortions due to echoing and add bias:
 - A BT485 biasing terminator at each end (unless the segment is less than 10 feet long)
 - A ½ watt, 120 ohm terminator at each end

v. Network Hierarchy

General

- The system architecture shall consist of a network of independent, stand-alone direct BACnet I/P-based digital control units and BACnet MSTP unitary controllers communicating over a two-tier local area network. Each control unit shall perform all specified control functions independently, including scheduling, alarming and storage of trend data. Failure of one (1) control unit shall have no effect upon any other unit in the network.
- Each direct digital control unit shall communicate with each other and with the existing servers. The DDC units, servers and workstations shall interface to the main communication network via multiple multi-port managed communication switches.
- To minimize network traffic and promote network health, point mapping shall be conducted as follows:
 - All direct mapping of networked points shall be through a main control router/global controller.
 - Direct peer-to-peer point mapping from controller to controller shall only be accepted if:
 - Controllers are on the same network bus.
 - No control router is present between controllers.
 - Outside Air point mapping: The outside air network points shall be pushed out (broadcast out) to all controllers with programming referencing these points.

Locally Separated BMS Local Area Network (LAN)

- BMS network shall be independent and isolated from MCIT WAN with one physical connection via CAT6/Ethernet. This connection will be between an approved NYULH BMS LAN switch and MCIT switch.
- Critical campus network topology shall be utilized for hospital infrastructure and Article 28 compliance spaces (e.g. operating, procedure, vivarium, Bio-Safety Labs). This network configuration is designed using three-tier hierarchical network topology.
- Midsize campus network topology shall be utilized for clinical practice and laboratory infrastructure. This network configuration is designed using three-tier hierarchical network topology.
- General campus network topology shall be utilized for office and residential infrastructure. This network configuration is designed using three-tier hierarchical network topology.

- Approved NYULH core, distribution and access switch shall only be used. All switches shall have 25% of their ports unused at the completion of the project. For an interim measure in the event of network switch failure, an approved unmanaged switch shall be installed until faulty switch is in kind replaced by the BMS vendor. BMS network architecture and connection to MCIT shall be approved by the Facilities Management Team before procurement.

See "Existing System Architecture Diagrams" section in References for topology diagrams referenced above.

vi. Network Protocols

- Communication protocol between servers, workstations, DDC and unitary controllers shall utilize ASHRAE Standard 135 BACnet. No manufacturer variations to ASHRAE Standard 135 BACnet published communication protocol standards and rules will be accepted. Each BACnet communication alarm and subscription services shall be configured as Confirmed service or Unicast transmission.
- For MS/TP communication efficiency, the following requirement must be adhered to:
 - All Devices must have a unique MAC ID and Device Instance.
 - All Software device instance are unique on the entire network.
 - Baud Rate must be the same of all devices including repeaters for given MS/TP trunk.
 - COV (Change of Value) Increment shall be set on ALL Analog Input and Value parameters with a number no less than 1.
 - Max Master on ALL Global Controllers shall be set according to Highest Node on MS/TP network trunk + 3.
 - EOL (End of Line) terminators shall be places on each end of a MS/TP trunk. Terminators resistance shall be determined by the BMS vendor recommended standard. No intermediate device shall have an EOL.
 - Voltage Polarity of RS-485 communication cable shall confirmed before adding additional controllers/devices.
 - MS/TP total length of twisted pair communication cable shall be less than 4000 ft. with 18 AWG, less than 2000 ft. with 22 AWG
 - MS/TP communication cable shall NOT be run in the same conduit as 24 VAC power
 - MS/TP communication cable shall NOT be run in the same conduit as conductors driven by Binary Outputs.
 - MS/TP communication cable shall NOT be run near electrical motors and only inside VFD plastic enclosures
 - Separate MS/TP communication loops shall be utilized for different equipment manufacturers.

vii. Integrations

General

- OEM equipment identified below shall be provided with communication interface option. Preferred communication protocol is BACnet MS/TP; however, the BMS is capable of communicating via other industry-standard protocols such as Modbus.
 - If a field server or gateway is required to communicate between the BMS and the equipment, it must be approved in writing by the NYULH Facility Management Team prior to implementation.
 - Equipment provider will be responsible for equipment start-up and to verify that communication to BMS is established and functional. The BATC Contractor must participate with the start-up to ensure proper communications.
 - On completion of the interface, the interface shall be demonstrated to the NYULH Facility Management Team and issues identified after start-up demonstration will require corrective action by the responsible party.

Equipment

- At a minimum, the following equipment shall be interfaced with the BMS:
 - Electric meters
 - Variable frequency drives
 - Packaged air conditioning units
 - Chillers
 - Room pressure monitors

Metering

- Metering shall be provided at the service entrance of each utility to each building.
- Hard-Wired Interface:
 - Mass flow (all non-electric meters)
 - BTU (energy meters only)
- Utility meters shall only use Modbus TCP protocol for integration.
- Utility Metering will be Bi-Directional meters and shall be set up with positive values for exporting, and negative values for importing.
 - At Manhattan Main campus the meter data shall be pulled into Blue Pillar system.
- Meters shall be integrated to the BMS when utilized for control, regardless of whether or not hard-wired I/O data points are provided.
- Meters shall also be integrated to third party data acquisition platforms as required.
- Projects shall provide building level submetering for steam, chilled water, natural gas and electricity. Chilled water submetering should be provided at each chiller. Specialty medical / lab equipment requiring chilled water shall be metered separately per manufacturer's recommendations.

Variable Frequency Drive Interface

- Furnish and install a communication interface between each fan and pump variable frequency drive and the direct digital control system. Preferred communication protocol shall be BACnet. BATC Contractor shall be responsible for coordinating with the VFD manufacturer for communication protocol requirements per equipment per project. Interface shall allow for simultaneous two-way communications between the VFD and BMS. This functionality shall allow an operator to remotely monitor and adjust all variables via the BMS operator workstation.
- Hard-wired Interface: Fans (Air Handling Systems, Heating and Ventilation Units, Exhaust Fans and Cooling Tower Fans)
 - Start/stop
 - Speed control
 - Safety shutdown (i.e., pressure switch and low temperature thermostat)
 - Common malfunction alarm
 - Drive not in Automatic
 - Note: Fan run status shall be monitored via current-sensing relay, provided and installed by BATC Contractor.
- Hard-wired Interface: Pumps
 - Start/stop
 - Speed control
 - Common malfunction alarm
 - Drive not in Automatic
- Communication Interface. The following input points shall be monitored via the BMS:
 - Speed feedback
 - Output frequency
 - Current (amps)
 - % torque
 - Power (kW)
 - Kilowatt hours
 - Operating hours
 - Drive temperature
 - All diagnostic warning and fault information
 - Remote fault reset
 - Keypad “Hand” or “Auto” selected
 - Bypass selected
 - Motor running in bypass mode
 - Motor running in inverter mode
 - Note: The BMS shall monitor the Auto position of the VFD serving the fan via the communication interface specified herein. On receiving indication that the fan is not operating in “Auto”, an alarm shall be activated at the workstation.

Packaged Air Conditioning Units

- Packaged air conditioning units to be provided with communication interface option. Preferred communication protocol is BACnet MS/TP. BATC Contractor is responsible for verifying the protocol provided with the units.
 - If a field server or gateway is required to communicate between the BMS and the unit, it must be approved in writing by the NYULH Facility Management Team prior to implementation.

Chillers

- Chillers to be provided with communication interface option. Preferred communication protocol is BACnet MS/TP. BATC Contractor is responsible for verifying the protocol provided with the chiller.
 - If a field server or gateway is required to communicate between the BMS and the chiller, it must be approved in writing by the NYULH Facility Management Team prior to implementation.

Room Pressure Monitors

- Room pressure monitors to be provided with BACnet MS/TP communication interface option.

viii. Power

a. Emergency Power

- All controllers shall be powered by emergency/standby powered circuits, regardless if the equipment being controlled (e.g. AHU, Chiller, etc.) is on emergency power.
- If emergency power is not available or perceived as not available, notify the NYULH facility management team that emergency/standby power is not available for controller use and NYULH staff will provide direction.
- Any DDC controller that's powered with Emergency Power shall be connected to a UPS power source. This includes Terminal units for Critical Spaces.

b. Terminal Unit Controller Power

For VAVs, CAVs, Fan-Powered VAVs, and Flow-Tracking:

- Power to terminal unit controls shall be 120VAC with enclosure-mounted 24VAC step-down transformer, fuse and disconnect switch.

For Fan Coil Units:

- Power to fan coil unit controls shall use a line-voltage-to-24VAC step down transformer, fuse, and disconnect switch.
- Control power shall come from the line-side of the fan coil unit power (upstream of the disconnect), to prevent communication loss when the fan coil unit is shut down for maintenance.

ix. Naming

a. Point Naming

- All point naming conventions shall be reviewed and accepted by the Facilities Management Team prior to being implemented.
- Each point name shall consist of the following components:
 - First two or three letter prefix = building identification.
 - Controls contractor shall confirm with the Facilities Management Team that the building prefix is unique and the convention does not already exist.
 - The next two or three letter or numerals = Equipment Identification
 - The last two or three letters = Device identification
 - Example: KP_HX1_SWT or KPHX1SWT = Kimmel Pavilion_Heat Exchanger 1_Supply Water Temperature

b. Controller Addressing

- All IP addresses are to be provided by MCIT and the Facilities Management Team once the necessary IT infrastructure is in place.
 - In the event of new building construction this infrastructure will not be in place until the building is near completion.
- BACnet device addressing is to be managed by the BATC Contractor and should be within the vendor's assigned address range as follows:
 - Alerton:
 - 500-999
 - 100000-199999
 - Automated Logic:
 - 300000-399999
 - Facilities Management Team and the Senior Controls Specialists are to provide BACnet device addresses for devices outside of the assigned vendor address ranges.
 - Facilities Management Team and Senior Controls Specialists must be provided with any necessary tools and software to change the BACnet device address on any devices installed.

x. Hardware Interlocks

a. Safety Circuit Engineering

- Safety devices (i.e., low temperature detectors, high pressure switches, low pressure switches, life safety shutdown relay contacts) shall be wired to starters and/or VFD's such that equipment will stop regardless if operating in hand, automatic, manual, or bypass.
- All safeties serving a variable frequency drive or starter (i.e., low temperature thermostat, fire shutdown contact, pressure switch, end switch, etc.) must be wired to a terminal strip outside of the VFD/starter, in a standard, labeled

enclosure where voltage readings can be taken to facilitate troubleshooting. Each safety should be wired to an individual pair of terminals and labeled as to what safety it is. In addition, all safeties must have individual auxiliary contact wired to the BMS for alarm monitoring. In lieu of a separate enclosure, it is acceptable to utilize the DDC field equipment panel.

- All systems requiring interlock wiring shall be hardwired interlocked and shall not rely on the BMS to operate. Interlock wiring shall be run in separate conduits from BMS associated wiring. Examples:
 - Emergency generator to fuel oil pump interlock, emergency generator damper interlock, etc.
 - Motorized damper interlock to fan starter.

b. Humidifier Valve Lockout

- The humidifier valve shall be prevented from opening via a hardwired interlock with a current sensing relay used to monitor fan run status.
- The current sensing relay shall be wired to a double-pole, double throw relay. One normally open pole shall be wired as an input to the DDC unit for fan run status. The other normally open pole shall be wired in series with the control signal to the humidifier valve such that when the fan is off, the humidifier valve shall be “hardwired” closed.
- Upon a fan trip, the humidifier valves shall immediately fail in the closed position.

c. High-Discharge Pressure Switches and Low-Suction Pressure Switches

- Pressure differential switches installed in the discharge of each supply, return and/or exhaust fan, which sense discharge pressure, shall stop the fan and transmit an alarm to the operator workstation if the pressure set point of the switch is exceeded.
- A separate pressure switch installed in the inlet of each supply, return and/or exhaust fan shall also stop the fan and transmit the alarm if fan suction pressure is below its set point.
- Pressure switches shall be automatic-reset type.
- The fan shutdown shall be operative whether the variable frequency drive Hand-Off-Inverter-Bypass switch is in the Inverter, Bypass or Hand position.
- Individual alarms (high and low) will be activated at the workstation.

d. Low Temperature Switches

Low-temperature switches (freezestats), one (1) for each cooling coil section, shall follow the following sequence:

- Pre-time delay timeout:
 - Any freezestat installed on the inlet of the cooling coil shall initiate a safety shutdown sequence upon sensing a temperature below the low limit setting of 35°F, locally adjustable at each freezestat.
 - Each normally closed freezestat shall have a unique input and identifier.
 - Any freezestat trip shall activate a time delay relay.
 - Upon activation of the freezestat switch status input, the following shall occur (before time delay timeout):
 - The unique freezestat switch status input will be ON.
 - The time delay relay will initiate the elapsed time countdown
 - A pre-alarm condition indicator shall activate at the BMS graphics containing the unique freezestat identifier
 - Preheat low limit setpoint will raise 10°F (adjustable)
 - CHW control valve will open to at least 25% (if it isn't already greater than 25% open)
- Post-time delay timeout:
 - Upon activation of any freezestat switch status input for a continuous elapsed time of 30 seconds via the adjustable time delay relay, the following shall occur:
 - The supply fan VFD(s) shall shut off via hardwired interlock to the VFD safety shutdown circuit.
 - The return fan VFD(s) shall shut off via hardwired interlock to the VFD safety shutdown circuit.
 - The chilled water valve shall open to 100%
 - The preheat valves shall control to a preheat discharge temperature setpoint of 95°F (adjustable)
 - A five star alarm must be generated each time a freezestat time delay relay activates.
 - Each time delay relay shall have an independent five star alarm.
 - After the freezestat switch status turns off, the five star critical alarm can be manually set to OFF via the BMS. Once the alarm is off and the unit can be manually restarted via the BMS.
 - The outside air intake damper(s) shall close
 - The supply fan discharge damper(s) shall close

e. Leak Detection

- On trigger of a leak alarm, associated cooling isolation and control valves shall shut while associated fans are allowed to operate.

f. Controller Reboot or Return from Power Failure

- On controller reboot or return from power failure, all control loop outputs shall be commanded to their position prior to reboot or power failure and all control loop integrals shall be zeroed, thus eliminating reset windup.

xi. HMI/Graphics

General Requirements:

- Dynamic graphics shall be created for each system interfaced with the building management system. Systems include, but are not limited to, air handling units, air conditioning units, heating and ventilation units, exhaust fans, pumps, chillers, heat exchangers, plumbing systems, electrical systems, etc.
- Summary graphics shall be created for systems as described herein. Summary graphics shall be updated, on a per-project basis, as modifications are made to each respective system. The summary graphics are intended to be live documents that continue to evolve as various systems are added, removed and/or modified.
- Where air handling or water systems serve areas other than Mechanical Equipment Rooms, provide dynamic color floor plan displays indicating the area served. The displays shall include all physical and virtual points associated with the respective system.
- The graphical interface shall allow users to access system schematics, floor plans, summary graphics, “as-built” documentation, operation and maintenance manuals via a hierarchal graphical penetration scheme and menu selection.
- Colors shall be used to indicate the status of points (e.g., RED = alarm, GREEN = normal) and these colors shall change as the status of the equipment changes. Provide a software program that shall notify the operator that a point has been placed in operator override. Notification shall be identified on the respective system graphic.
- Dynamic temperature values, humidity values, flow values and status indication shall automatically update to represent current conditions without operator intervention and without predefined screen refresh rates.
- All values displayed on the graphics shall include appropriate engineering units.
- Values/icons for points which are placed in an override or locked state by an operator command shall clearly be identified and displayed in a manner that the operator can identify these locked points.
- Performance overviews shall be provided for each building totaling its actual energy usage with a detailed comparison to its expected usage, on a month by month basis, as well as an annual basis.

Sitewide Main Page shall contain the following:

- Site map with links to each individual building.
- Link to each campus summary graphic.
- Common Critical Data:
 - Outdoor air temperature
 - Outdoor air humidity
 - Outdoor air CO2
 - Outdoor air enthalpy
 - Outdoor air dewpoint.

Individual Building Main Page:

- Graphics should be organized by building and floor with links to all the equipment that serves that floor on the graphics link.
- Building Operator Links (the following are examples from the NYULH Main Campus):
 - Tisch Hospital
 - Ancillary
 - Millhauser
 - Alumni Hall
 - Medical Science Building - Berg
 - Coles Student Laboratory
 - Schwartz Lecture Hall
 - Skirball Institute
 - Smilow Research Center
 - Schwartz Health Care Center (HCC)
 - 660 First Avenue
 - Energy Building
 - Greenberg Hall
 - Kimmel Pavilion
 - Science Building
- Each building shall be presented with an individual main page. The main page shall consist of the following:
 - Link to the sitewide main page
 - Link to each respective floor plan of the building
 - Link to building summary graphics for each of the following systems:
 - Condenser water system and all connected equipment (i.e., packaged air conditioning units, Cold Rooms, freezers, etc.), regardless of whether the equipment is interfaced with the BMS or not (single-line format).
 - Chilled water system and all connected equipment (i.e., air handling units, packaged air conditioning units, Cold Rooms, freezers, etc.), regardless of whether the equipment is interfaced with the BMS or not (single-line format).
 - Air handling unit relevant data such as run status, supply temperature, static pressure, and active alarm (tabular format).

- Supply, return and exhaust duct distribution and all connected equipment (single-line format).
 - VAV box relevant data such as temperature set point, actual temperature and list of rooms served. (Tabular Format).
 - Electrical distribution system, inclusive of all electrical status, alarm and metering points (single-line format).
 - Environmental boxes, refrigerators and freezers (tabular format).
 - Instrument air systems pressure readings, interconnections, risers, branch piping, isolation valves.
 - Communication network indicating all controllers, wiring configurations, controller addresses, controller location. Note: This is not a dynamic graphic. Intent is for a static graphic indicating “as-built” for BMS communication network.
- Wherever possible, summary graphics shall include links to systems illustrated on the respective summary graphic as well as other systems associated with the system depicted. For example, VAV summary graphic should contain the AHU and reheat water system links.
 - Links to each system group. Groups are defined as follows:
 - Air handling units
 - Air conditioning units
 - Exhaust fans
 - Chilled water system
 - Condenser water system
 - Hot water system
 - Secondary water systems
 - Process cooling systems
 - Domestic water
 - Medical air systems
 - Operating Rooms
 - Environmental boxes
 - Generators
 - UPS systems
 - Automatic transfer systems
 - Double-ended substations
 - Individual links to each piece of equipment and/or system within each group. All graphics must show the name of the system and its service area. All systems that serve the system illustrated on the graphic, must be identified and linked to. For example, if a fan system provides the outside air delivered to a fan coil unit, the fan system tag must be identified at the outdoor air intake on the graphic. If a system serves VAV boxes, this must be indicated on the system graphic with a link to the VAV boxes provided.
 - Refer to the Reference Section for sample graphic indicating a typical floor plan.

Location Summary Graphics:

- Graphics shall include the following:
 - Steam system (displayed in a single-line format)
 - Chilled water system (displayed in a single-line format)
 - Electric distribution systems (displayed in a single-line format)
 - Pneumatic air systems (displayed in a single-line format)
 - Domestic water system single-line riser diagram showing domestic water meter POE, pumping system, water tower, domestic hot water systems and other water users.
 - Medical air system per building
 - Operating Rooms (tabular format)
 - Energy metering (tabular format)
 - Air handlers/exhaust fans by building and floor location
 - Reheat/perimeter/secondary water by system by building and floor location (displayed in a "single line" format)
 - Generators by building (tabular format)
 - FCU's by building and floor (tabular format)
 - Walk-in boxes, environmental boxes, hot rooms (tabular format)
 - ATS (tabular format)
 - UPS (tabular format)
 - Sump/ejector pumps (tabular format)
 - Critical Labs (Berg/Smilow ABSL-3 temps, pressures)
 - Refrigeration cooling towers (displayed in a "single line" format)
 - Control air plants (displayed in a "single line" format)
 - Steam PRV's and perimeter steam control valves (tabular format)
 - Sump/ejector/condensate pump (tabular format)
 - Animal holding rooms (tabular format)
 - Fire systems, preactions (tabular format)
 - Decontamination showers (tabular format)
 - Room pressure monitoring (tabular format)
 - Domestic water, water heaters, booster pumps, house tanks (tabular format)
 - Communication network indicating workstations, servers, network switches and primary controllers with respective locations and wiring configurations.
 - Note: This is not a dynamic graphic. Intent is for a static graphic indicating "as-built" for BMS communication network.
- Wherever possible, summary graphics shall include links to systems illustrated on the respective summary graphic as well as other systems associated with the system depicted. For example, chilled water system summary graphic should contain links to each chilled water system.
- Campus summary graphics shall be a compiled building system overviews. The campus single lines will be the summation of the building single line drawings. All systems should be grouped together with similar systems in a building. If there are no other similar systems in the building a new overview shall be started for that system with LED alarm bringing you to that page in the event of a critical alarm. NO GRAPHICS SHALL BE GROUPED OR LABELED "miscellaneous".

- Summary graphics shall be updated as the systems they represent are modified.

Floor Plans:

- Floor plans shall display air and piping distribution systems in single-line format.
- Floor plans shall indicate location of all equipment located on the floor (i.e., exhaust fans, air conditioning units, VAV boxes, environmental boxes, etc.) as well as links to respective individual equipment graphics. Equipment locations shall be as-installed locations.
- Floor plans shall indicate location of all equipment that is not located on the floor, but serves the floor (i.e., air handling units, exhaust fans and water systems) as well as links to respective individual equipment graphics. Equipment locations shall be as-installed locations.
- Floor plans shall show dynamic variable monitoring space conditions (i.e., temperature, humidity, CO₂, room pressures, etc.) in actual field-installed location of sensing device.
- Floor plans to indicate latest room numbers.

Equipment:

- Each individual equipment graphic shall include the following links:
 - Sitewide main page
 - Individual building main page
 - Each floor served by the equipment
 - Summary graphic associated with the system
- For example: Air handling unit graphic is to include links to the following summary graphics:
 - Chilled water system
 - Steam or hot water system
 - VAV box summary system
 - Network communications
- At the top of each graphic, indicate the equipment tag, location and what it serves (e.g., AHU-TH-2-1, 2nd Floor MER, Floors 3 - 7)
- Individual equipment graphics shall indicate all input/outputs points associated with the system. Points shall be shown in the appropriate locations.
- Set point increments shall be defaulted as follows. Any modifications must be approved by the Facility Management Team.
 - Temperature: 1°F
 - Humidity: 1% RH
 - Static Pressure: 0.1 in w.c.
 - Airflow: 100 cfm
 - Water flow: 50 gpm
 - Water differential pressure: 2 psig
- Individual equipment graphics shall include links to graphic page of all points monitored via third-party equipment interface. For example, provide link for display page of all data points associated with variable frequency drive.

- Graphics shall clearly indicate the fail state positions for all BMS controlled devices.

xii. Reports

General Requirements:

- Reports shall be generated on demand or via a predefined schedule.

Predefined Reports:

- The following predefined reports shall be created and updated as modifications are made to the respective equipment and/or facility:
 - Controller Online/Offline Status (Campus-Wide):
 - Report to include controller tag, location, online/offline status.
 - Report generated automatically on a daily basis.
 - Controller Reboot Status (Campus-Wide):
 - Report to include controller tag, location, quantity of reboots and time of occurrence.
 - Report generated automatically on a daily basis.
 - Equipment Uptime (per Building):
 - Report to include equipment tag, location, required uptime, actual uptime.
 - Report generated automatically on a monthly basis.
 - Operating Room Humidity:
 - Report to include Operating Room tag, location, humidity level over 24-hour period (highest, average, lowest).
 - Report generated automatically on a daily basis for a 24-hour period.
 - Operating Room Pressurization:
 - Report to include Operating Room tag, location and pressurization level over 24-hour period (positive, neutral, negative).
 - Report generated automatically on a daily basis for a 24-hour period.
 - Domestic Hot Water Temperature (per Building):
 - Report to include:
 - Common supply water temperature
 - Monthly hours
 - Hours in Compliance (98 - 117.5°F) - Identified by total hours and percentage
 - Out of Compliance hours (117.5 - 120°F) - Identified by total hours and percentage
 - Out of Compliance hours (120 - 125°F) - Identified by total hours and percentage
 - Out of Compliance hours (125 - 200°F) - Identified by total hours and percentage
 - Out of Compliance hours (90 - 98°F) - Identified by total hours and percentage

- Out of Compliance hours (80 - 90°F) - Identified by total hours and percentage
- Out of Compliance hours (35 - 80°F) - Identified by total hours and percentage
 - Report generated automatically on a daily basis for a 24-hour period
- Room Pressurization (per Building - Not Including Operating Rooms):
 - Report to include room tag, location, required pressurization mode, actual pressurization mode.
 - Report generated automatically on a daily basis for a 24 hour period.
- Chilled Water Supply and Return Temperature (Campus-Wide):
 - Report to include chilled water temperature transmitter tag, location, actual temperature (highest, average and lowest). Note: Temperature data referenced in this report is only specific to each chiller plant's common chilled water supply and return temperature.
 - Report generated automatically on a daily basis for a 24 hour period.
- Chilled Water Differential Pressure (Campus-Wide):
 - Report to include chilled water differential pressure transmitter tag, location, actual pressure (highest, average and lowest). Note: Differential pressure data referenced in this report is only specific to each transmitter located in the campus chilled water loop.
 - Report generated automatically on a daily basis for a 24-hour period.

I. References

i. Reference Standards

Products in this subsection shall be built, tested, and installed in compliance with the specified quality assurance standards; latest versions, unless noted otherwise.

- Electrical Standards: Provide electrical products that have been tested, listed and labeled by UL and comply with NEMA standards as well as NFPA 70 (National Electric Code).
- NEMA Compliance: Comply with NEMA standards pertaining to components and devices for electrical control systems.
- NFPA Compliance: Comply with NFPA 90A "Standard for the Installation of Air Conditioning and Ventilating Systems" where applicable to controls and control sequence.
- Install all BMS components, panels, and wiring in compliance with NEC and all local electrical codes.
- DDC devices shall use the latest version of ANSI/ASHRAE Standard 135 "BACnet – Building Automation and Control Networking Protocol" standard for communications and have passed BTL certification as available.
- UL Compliance: DDC Controllers shall comply with UL916 Standard for Energy Management Equipment. DDC Controllers associated with equipment utilized in a smoke control application shall also comply with UUKL-UL 864 "Standard for Control Units and Accessories for Fire Alarm Systems".

- National Institute of Standards and Technology (NIST), NIST IR 6392 Annex B: Profiles of Standard BACnet Devices.
- Electronics Industries Association(EIA)
 - EIA-232: Interface between Data Terminal Equipment and Data Circuit Terminating Equipment employing serial binary data interchange
 - EIA-485: Standard for Electrical Characteristics of Generator and Receivers for Use in Balanced Digital Multi-Point System

ii. VAV Balancing Procedure

Definitions:

- Supply or Exhaust Velocity Pressure = Analog Input into Controller from Field
- K-Factor = Value from Box Manufacturer’s Design Table
- Calibration Factor = Number calculated during balancing

Calculating CFM from Velocity Pressure Equation:

- $CFM = \sqrt{\text{Velocity Pressure}} \times K\text{-Factor} \times \text{Calibration Factor}$

Balancing Procedure

- Initial Parameters:
 - Calibration Factor to 1.00
 - Set K-Factor according to Box Manufacturer based off Box Size:

Titus AeroCross

Inlet Size	K-Factor
5	273
6	469
7	612
8	867
9	1098
10	1353
12	1802
14	2469
16	3366
24X16	6358

Amenostat EZT & XAFT

Inlet Size	K-Factor
5	287
6	469
7	612
8	867
9	1098
10	1353
12	1802
14	2469
16	3366
24X16	6358

Note: K-Factors shown are for 1.0 ΔP

Testing Box at Maximum & Minimum Design CFM:

- Set Box to Maximum Design CFM
- Balancer will obtain a CFM hood reading
- BMS Vendor will calculate new Calibration by using this equation
 - $\text{New Calibration Factor} = (\text{Balancer CFM Reading}) / (\text{BMS CFM Reading})$
- BMS Vendor will enter new calibration factor in replace of the initialized calibration factor
- Balancer final CFM hood reading shall not exceed 10% of BMS final CFM reading at maximum design setpoint
- Set Box to Minimum Design CFM
- Balancer will obtain a CFM hood reading
- Balancer final CFM hood reading shall not exceed 10% of BMS final CFM reading at minimum design setpoint

iii. Network Architecture

- a. BMS Network Architecture shall be reviewed by RED+F and MCIT
- b. Wherever possible, network architecture shall employ a Zone and Conduit strategy as per IASC99 ISA/ IEC 62443 series of standards

iv. Typical Floor Plan Sample BMS Graphics

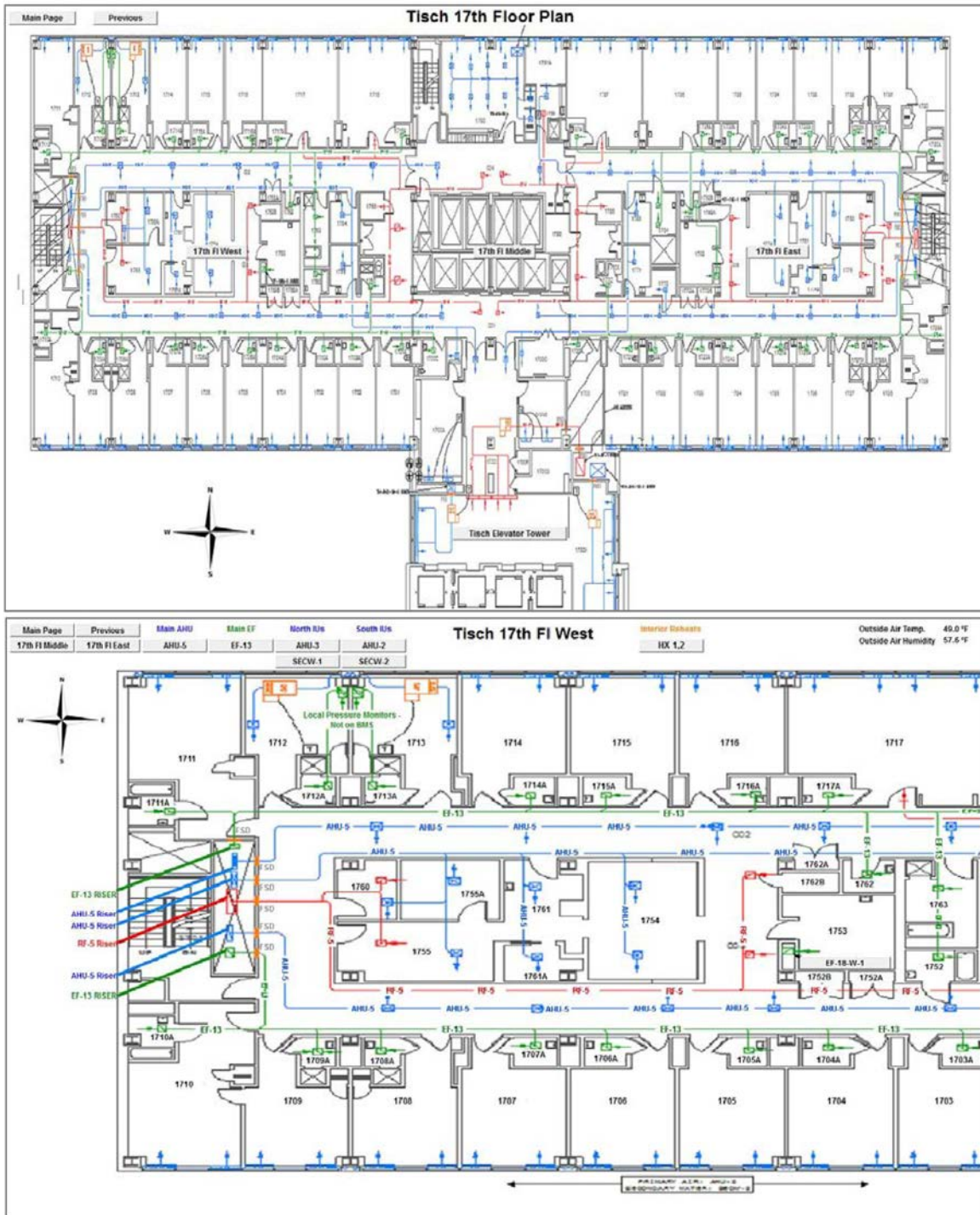

v. BMS IT Architecture and Remote Access Requirements

- The BMS vendor shall install a dedicated BMS server at each site (per building or per campus). The server shall be placed in the BDF. If the BDF is not available, the IDF may be used. The BMS Network shall have one point of connection to the MCIT network.
 - BMS vendor to provide the smallest form factor server possible.
 - MCIT PM will confirm BDF or IDF availability, power availability and be responsible for ordering any shelving or accessories required to mount the server.
 - Emergency Power with UPS is preferable. If UPS power is already available in the BDF, this shall be used.
 - If UPS power is not available, a stand-alone UPS shall be installed.
 - Standard model: APC SUA500PDRI-H. UPS is available in both rack mounted and standalone models.
- The server shall be connected to a managed switch (acceptable models listed)
- MCIT to provide a patch cable from the BMS Managed Switch to the MCIT network
- The MCIT PM shall work with IT Security and Network Security to specify, purchase and install the firewall (if not already present at the site).
- The BMS contractor is responsible for all low voltage cabling to the BMS managed switch. MCIT can assist with pathways and routing.
- The BMS network shall use a private class C IP network: 192.168.xxx.xxx/16
- If this IP scheme cannot be used, review with MCIT Joint Architecture and Engineering Review is required
- The BMS contractor must provide to the project team (both the MCIT and RED+F PMs) a network architecture single-line diagram showing the following information:
 - For each device, identify the following
 - Device Name
 - Device type (make, model)
 - Physical Location
 - IP address if available
 - MAC address (can be added later if device has not yet been ordered)
 - Between devices, identify the communication protocols and if applicable, wire type
 - Identify direction of traffic flow
 - Identify ports used to communicate externally
 - Identify means of external data storage
- The MCIT PM will create a ticket in HEAT to enable RDP, HTTPS and SSH on the firewall

- All vendors requiring access to the BMS must have an NYULH KID.
 - KID requests are placed by the RED+F sponsor: The sponsor is either the Facilities Manager, Operations Manager or Tenant Coordinator for the site.
 - Do not request an NYULH email account/address
 - After the KID is received, the Sponsor must create subsequent new requests for CyberArk and Advanced Access VPN
 - Once the Contractor has received their KID and the resultant access to the InsideHealth portal (insidehealth.nyumc.org), they must register for the DUO two-factor authentication. Upon login to InsideHealth, they will be prompted with instructions to register.
 - Do not download DUO from the App Store / Google Play and install directly on your device. This will not work. It must be downloaded from the InsideHealth portal (insidehealth.nyumc.org).
- The BMS should have an HTML5 Web Application. This will be the primary means of accessing the BMS for both NYULH and vendor staff.
 - The local BMS IP shall be access from the NYULH network via a NAT IP address.
 - The MCIT PM will request that the BMS website IP be NAT'ed to an NYULH 10. IP address
 - From on-site at NYULH, the BMS web app can be accessed from any device
 - For remote access, F5 BIG IP edge client shall be used, and can be downloaded from the InsideHealth portal (insidehealth.nyumc.org).
- For BMS vendors requiring remote access to the BMS server, CyberArk must be used
 - MCIT PM will place a ticket to NAT the server IP to a local NYULH IP
 - Once CyberArk access is approved (see above), the vendor will need to add the 10. IP address of the server to their Cyberark profile.
 - Cyberark supports both Windows and Linux environments
 - Remote Desktop via Cyberark is the only approved method of remote access. Other products (such as Teamviewer, VNC, LogmeIn) are not permitted.
 - BMS vendor is responsible for keeping anti-virus and patches up to date on all vendor-managed equipment.
- The BMS vendor shall configure email alarms via NYULH's smtp relay
 - smtp.nyumc.org (10.185.64.51) Port 25
 - From: NYUOffsites@nyulangone.org
 - To: <email addresses/distribution list address>
 - Note: Distribution lists can be created by MCIT by opening a ticket
 - No username/password required
 - Authentication: None
 - Gmail, Yahoo, Hotmail, etc. email relays are not permitted.

vi. Non-Standard CIOT System Remote Access Requests

In some cases, should the non-standard procedure for configuring remote access to an independent CIOT be available, the following guidelines shall be followed:

- The OT vendor or Design Engineer shall prepare a network architecture diagram. The diagram must include the following:
 - A single-line drawing of all networked devices
 - For each device, identify the following
 - Device Name
 - Device type (make, model)
 - Physical Location
 - IP address if available
 - MAC address (can be added later if device has not yet been ordered)
- Between devices, identify the communication protocols and if applicable, wire type
 - Identify direction of traffic flow
 - Identify ports used to communicate externally
 - Identify means of external data storage
- The Network Diagram shall be reviewed by The Project Manager, BMS Standards Committee, The Senior Manager, RED+F Information Strategy, and the Facility Manager
- Once approved by the Senior Manager, Information Strategy, if external connectivity (to the internet or to the MCIT network), a review must be completed by MCIT Security. This can be requested through MCIT Heat Ticket System
- Upon approval from MCIT Security, review is required by MCIT Network Security to determine IP address and firewall requirements.
- In cases where a web server is not available, The OT vendor can provide an operator workstation or laptop. The BMS vendor will be responsible for patching, anti-virus and updates in accordance with NYULH MCIT standards. Any exceptions to anti-virus policy must be reviewed and approved by MCIT Security.

END OF BUILDING MANAGEMENT SYSTEM SUBSECTION

3. PROJECT CLOSE-OUT



CLOSE-OUT PACKAGE

At the end of a project, close-out packages are to be completed and submitted to RED+F per the Substantial Completion and Project Closeout Checklists shown below. The goal is to have all projects closed 120 days after the first user has moved in. The A/E Team shall request the latest version of these checklists from the RED+F PM at time of close-out.

SUBSTANTIAL COMPLETION CHECKLIST	
PROJECT NAME:	
LOCATION:	
ARCHITECT:	
ENGINEER:	
CONTRACTOR:	
RED+F PM:	

Legend
 A/E: Architect or Engineer
 C: Contractor (General Contractor or Construction Manager)
 RED+F: Project Manager

The following items must be completed for Substantial Completion to be declared for the above referenced project:

Item	Responsible Party	Date Received	Description
CONTRACTOR ITEMS REQUIRED FOR SUBSTANTIAL COMPLETION			
1	C		Work must be sufficiently complete in accordance with the Contract Documents so that the Owner can occupy or use the Work for its intended purpose. Contractor completes all construction and other tasks necessary to achieve this. Substantial Completion includes DOB issuance of a Letter of Completion or TCO and for Article 28 projects, a DOH Letter of Approval.
2	C		Arranges all required special inspections, corrects non-compliant conditions and schedules re-inspections until Work is approved (to be done as construction progresses).
3	C		Coordinates filing of all required reports with DOB/FDNY to allow DOB/FDNY to close out permits as required.
4	C		Provides Medical Gas Certifications.
5	C		Provides copies of all approved test data (MEP,FA, FP).
6	C		Provides Electrical Panel Schedules and Keys (3 copies of each).
7	C		Provides valve tag charts with associated location plan.
8	C		Provides all As-Built Drawings maintained during construction.
9	C		Coordinates orientation with in-house staff for training and ongoing maintenance/engineering operations. Training shall be Tuesday - Thursday with two training sessions (730am and 330pm)
10	C		Provides equipment list of all major MEP/FP/FA equipment removed and installed in NYULH-approved Excel sheet. (Obtain from Facilities).
11	C		Provides equipment startup sheets.
12	C		Provides approved testing and balancing report (water and air).
13	C		Holds Facilities/Real Estate/Environmental Services pre-whiteout walkthrough prior to closing ceilings.
14	C		Resolves and documents pre-whiteout walkthrough issues for Facilities/Real Estate/Environmental Services signoff.
15	C		Provides Fire Smoke Damper and Fire Damper equipment list and location drawings.
16	C		Arranges for Functional Testing of MEP equipment with Commissioning Authority and fixes all life safety and equipment operational defects.
17	C		Provides Operations and Maintenance Manuals.

CONSULTANT AND RED+F ITEMS REQUIRED FOR SUBSTANTIAL COMPLETION

18	A/E		Conducts a site-inspection tour for NYULH team and consultants. Prepares a comprehensive list of items to be completed or corrected prior to final payment (the Punch List) for RED+F approval.
19	File Rep		Submits equipment verification to DOB and receives the permit.
20	Special Insp		Submits Special Inspection Reports.
21	File Rep		Submits reports to obtain Letter of Completion or TCO.
22	EOR		Verifies that equipment installed is what was specified.
23	A/E		For DOH projects, Completed Construction Certification Letter for Architects and Engineers.
24	RED+F		Copies of all AHJ-approved drawings (AHJs incl. DASNY, DOB, & FDNY) and letters (e.g., TCO, LOC, LOA, LOR) and forms must be archived in BuildFlow.
25	RED+F		Communicate project go-live to NYULMC: MRM update/Signage (elevators, etc.)/Occupancy date for Real Estate.

SIGNATURES

RED+F Project Manager + Date	_____
RED+F Program Director + Date	_____
RED+F Director, Regulatory Review + Date	_____
RED+F VP, Design & Construction + Date	_____
RED+F Asst Director, Commissioning + Date	_____
RED+F VP, Facilities Operations + Date	_____

PROJECT CLOSEOUT CHECKLIST	
PROJECT NAME: LOCATION: ARCHITECT: ENGINEER: CONTRACTOR: RED+F PM:	<div style="text-align: right; font-size: small;"> Legend A/E: Architect or Engineer C: Contractor (General Contractor or Construction Manager) RED+F: Project Manager </div>

The following items must be completed for Project closeout to be declared for the above referenced project:

Item	Responsible Party	Date Received	Description
CONTRACTOR ITEMS REQUIRED FOR PROJECT CLOSEOUT			
1	C		Obtains Equipment Use Permits
2	C		Resolves all items on commissioning issues log that are the Contractor's responsibility.
3	C		Provides all final approved equipment submittals.
4	C		Completes all punchlist work.
5	C		Final progress photos.
6	C		Provides all closeout material documentation in Buildflow, separated per approved NYULH closeout folder structure. Closeout material shall include all items listed on the Substantial Completion Checklist as well as all submittals of installed equipment.
7	C		Affidavit of Release of Liens (AIA G706A or as otherwise provided in the contract)
8	C		Affidavit of Payment of Debts and Claims

CONSULTANT AND RED+F ITEMS REQUIRED FOR PROJECT CLOSEOUT

9	CxA		Signs off commissioning issues log.
10	CxA		Provides final Commissioning Report
11	CxA		Provides Systems Manuals
12	RED+F		Latest revision of CD's in DWG format and PDF format documents received and forwarded to SPM to update Planon and Alchemy.
13	RED+F		Closed out ILSM forms, signed-off by EH&S.
14	RED+F		Closed out Penetration form, signed-off by Facilities Operations.
15	RED+F		Coordinate inspections conducted by the New York State Department of Health. Complete DOH binder and submit.
16	A/E		Certificate of Payment (AIA G702) certifying completion of all contract Work. *
17	A/E		Finish and Furniture Booklets as per Design Guidelines
18	RED+F		Certificate of Substantial Completion (AIA G704).
19	RED+F		Permanent Certificate of Occupancy, if applicable.
20	RED+F		Copy of Temporary Certificate of Occupancy or Letter of Completion (N/A if in receipt of PCO).
21	RED+F		Copy of DOH Pre-Occupancy Survey used at inspection.
22	RED+F		Facility Project Letter of Acceptance and Completion issued by the New York State Department of Health.

SIGNATURES

RED+F Project Manager + Date	
RED+F Program Director + Date	
RED+F Regulatory Review + Date	
RED+F VP, Design & Construction + Date	
RED+F Asst Director, Commissioning + Date	
RED+F VP, Facilities Operations + Date	

* Work includes all construction and services required by the Contract Documents.

PHOTOGRAPHY

The RED+F Project Manager shall engage a professional photographer pre-approved by the Design Studio to photograph the project after construction is complete and before move-in. The cost of this shall be included in the Project Budget. A professional photographer may also be engaged by the Architect to photograph the project. The Architect shall request pre-approval from NYU Langone Health of the photographer they wish to use.

The RED+F PM and GC/CM shall allocate sufficient time in the schedule to professionally photograph the project. The time shall be clearly shown on the project schedule. The length of time needed will be based on the size and scope of the project. At a minimum two days will be allocated for spaces up to 50,000 GSF. One more day shall be allocated for each additional 50,000 GSF. Final photography must be scheduled as follows:

- After construction is complete and no contractors are on the premises
- After final cleaning has occurred
- Before any move-in preparation has begun

All the major public spaces and architecturally important components shall be photographed sufficiently to show the scope of the project. Final high resolution files shall be provided to the Design Studio at RED+F via the RED+F PM without charge to NYU Langone. Below are a few examples:



Hassenfeld Children's Hospital - Jeff Goldberg/Esto



Energy Building - Jeff Goldberg/Esto



Science Building - Rene Perez

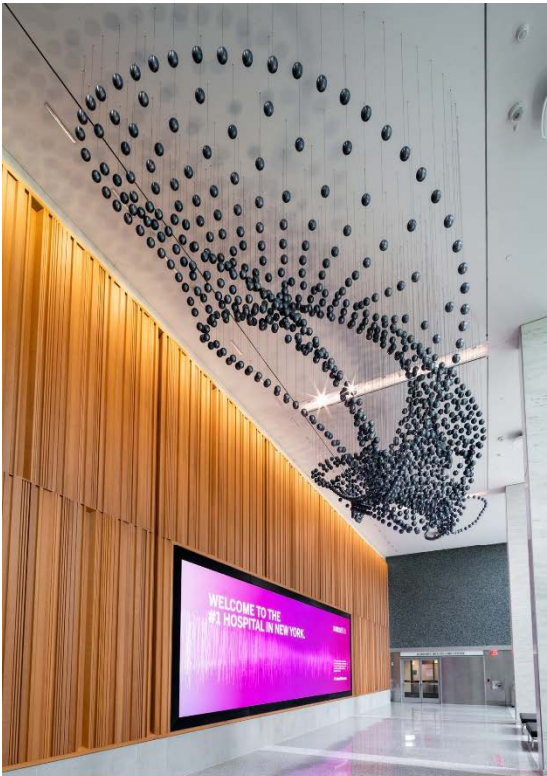

Murphy Alumni Hall - Rene Perez



Science Building - Rene Perez

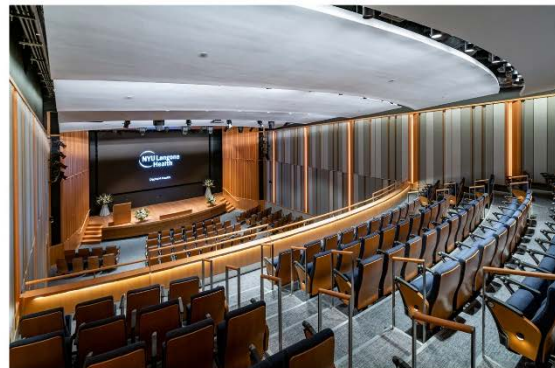

Murphy Alumni Hall - Rene Perez



Kimmel Pavilion - Jeff Goldberg/Esto



Kimmel Pavilion - Jeff Goldberg/Esto

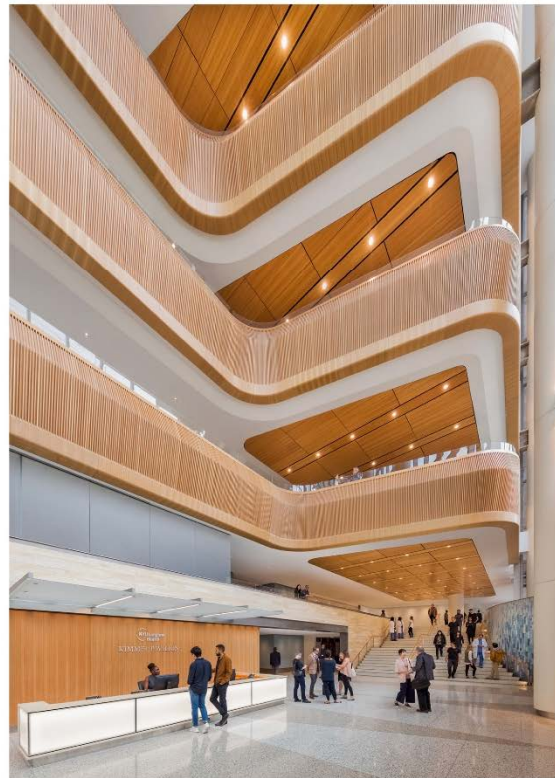

Kimmel Pavilion - Jeff Goldberg/Esto

POST-OCCUPANCY EVALUATIONS

RED+F is continually seeking to improve the Design and Construction process of the built environment and has established a Built Environment Improvement Cycle. The cycle, which consists of Design-Construction-Occupancy-Evaluation and back to Design, allows for continual improvement of the built environment by establishing a Post-Occupancy Evaluation phase.

The Post-Occupancy Evaluation phase occurs after the users have moved in and utilized the space for a certain period of time, typically about a year. The intent of the Post-Occupancy Evaluation is to provide feedback on the design and general performance of materials and furniture over a period of time.

The RED+F Design Studio performs the Post-Occupancy Evaluation. It is important the same group perform the evaluation in order to maintain a consistent basis of analysis between projects. Results of Post-Occupancy Evaluations are then used to inform Project Teams and update the Design Guidelines. For example, materials and furniture that are not holding up well are removed from the Design Guidelines. Materials and furniture that are not part of the Design Guidelines but were approved for a particular project and have been holding up well are considered for inclusion in the Design Guidelines. This process reduces maintenance costs and streamlines the Design process.

Built Environment Improvement Cycle

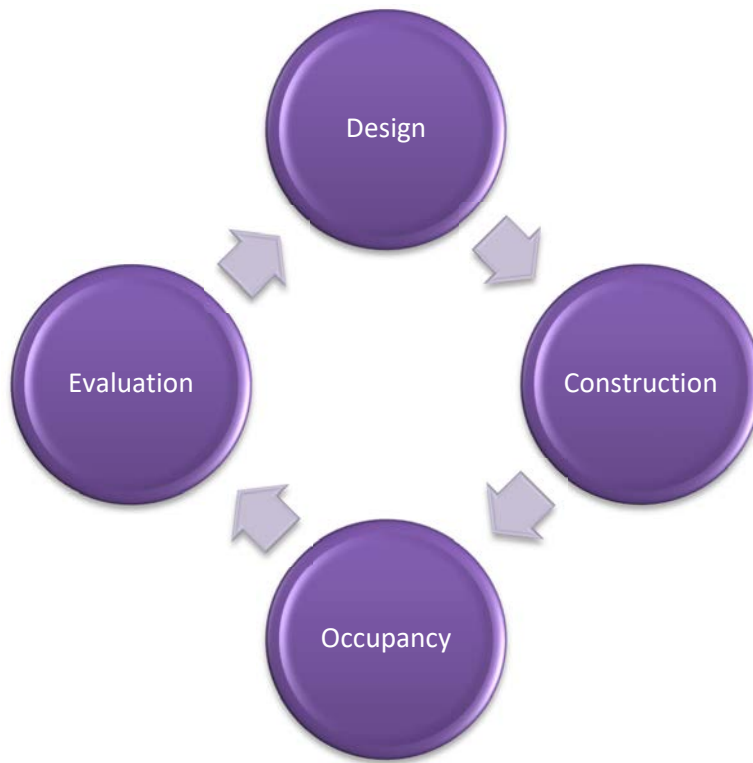

POST-OCCUPANCY EVALUATION FORM

The intent of the Design Post Occupancy Evaluation Form is to provide feedback on the overall design and general performance of materials and furniture over a period of time. The information will be used to continually update the Design Guidelines.

PROJECT NAME: _____

PROJECT ADDRESS: _____

NAME OF ARCHITECT: _____

DATE OF OCCUPANCY: _____

DATE OF EVALUATION: _____

NAME OF EVALUATOR(S): _____

EVALUATION ITEMS	RATINGS (1-10)
1. Floor Finishes.....	#
2. Wall/Base Finishes.....	#
3. Doors/Hardware.....	#
4. Millwork/Casework.....	#
5. Ceilings.....	#
6. Lighting.....	#
7. Furniture.....	#
8. Signage/Wayfinding.....	#
9. Specialty (Reception Desk, Nurse Station, etc.).....	#
10. Other (Pantry Appliances, Plumbing Fixtures, Toilet/Building Accessories, Trash/Recycling Receptacles, etc.)	#
Total	#

* Ratings: 1 = Needs Work, 3 = Fair, 5=Average, 7=Above Average, 9=Very Good, 10=Exceptional

